



CITY OF CENTRAL POINT

Oregon

City Council Meeting Agenda Thursday, June 27, 2019

Next Res(1581) Ord (2058)

- I. **REGULAR MEETING CALLED TO ORDER**
- II. **PLEDGE OF ALLEGIANCE**
- III. **ROLL CALL**
- IV. **PUBLIC COMMENTS**

Public comment is for non-agenda items. If you are here to make comments on a specific agenda item, you must speak at that time. Please limit your remarks to 3 minutes per individual, 5 minutes per group, with a maximum of 20 minutes per meeting being allotted for public comments. The council may ask questions but may take no action during the public comment section of the meeting, except to direct staff to prepare a report or place an item on a future agenda. Complaints against specific City employees should be resolved through the City's Personnel Complaint procedure. The right to address the Council does not exempt the speaker from any potential liability for defamation.

- V. **CONSENT AGENDA**
 - A. **Approval of June 13, 2019 City Council Minutes**
 - B. Street Closures for 4th of July

- VI. **ITEMS REMOVED FROM CONSENT AGENDA**

- VII. **PUBLIC HEARING**

Public comments will be allowed on items under this part of the agenda following a brief staff report presenting the item and action requested. The presiding officer may limit testimony.

- A. First Reading - Ordinance Updating and Adopting the Employment Buildable Lands Inventory (BLI), an adjunct to the Land Use Element. (Holtey)
- B. First Reading - Ordinance Updating and Adopting the Central Point Comprehensive Plan Economic Element (2019-2039). (Holtey)

- VIII. **ORDINANCES, AND RESOLUTIONS**

- A. Resolution No. _____, Approving the Award of a Contract for the City Council Chambers Renovation Project (Clayton)

- IX. **BUSINESS**

- A. Community Center - Ad Hoc Committee Recommendation (Samitore)
- B. Parks Banking - East Side Transit Oriented Development (Samitore)

- X. **MAYOR'S REPORT**

Mayor
Hank Williams

Ward I
Neil Olsen

Ward II
Kelley Johnson

Ward III
Brandon Thueson

Ward IV
Tanea Browning

At Large
Rob Hernandez

At Large
Michael Parsons

XI. CITY MANAGER'S REPORT

XII. COUNCIL REPORTS

XIII. DEPARTMENT REPORTS

XIV. EXECUTIVE SESSION

The City Council will adjourn to executive session under the provisions of ORS 192.660. Under the provisions of the Oregon Public Meetings Law, the proceedings of an executive session are not for publication or broadcast.

XV. ADJOURNMENT

Individuals needing special accommodations such as sign language, foreign language interpreters or equipment for the hearing impaired must request such services at least 72 hours prior to the City Council meeting. To make your request, please contact the City Recorder at 541-423-1026 (voice), or by e-mail to Deanna.casey@centralpointoregon.gov.

Si necesita traductor en español o servicios de discapacidades (ADA) para asistir a una junta publica de la ciudad por favor llame con 72 horas de anticipación al 541-664-3321 ext. 201

CITY OF CENTRAL POINT

Oregon

City Council Meeting Minutes Thursday, June 13, 2019

I. REGULAR MEETING CALLED TO ORDER

The meeting was called to order at 7:00 PM by Mayor Hank Williams

II. PLEDGE OF ALLEGIANCE

III. ROLL CALL

| Attendee Name | Title | Status | Arrived |
|-----------------|----------|---------|---------|
| Hank Williams | Mayor | Present | |
| Neil Olsen | Ward I | Present | |
| Kelley Johnson | Ward II | Present | |
| Brandon Thueson | Ward III | Present | |
| Taneea Browning | Ward IV | Present | |
| Rob Hernandez | At Large | Present | |
| Michael Parsons | At Large | Present | |

Staff members present: City Manager Chris Clayton; City Attorney Sydnee Dreyer; Finance Director Steve Weber; Police Chief Kris Allison; Police Captain Dave Croft; Parks and Public Works Director Matt Samitore; Community Development Director Tom Humphrey; Human Resource Director Elizabeth Simas and City Recorder Deanna Casey.

IV. PUBLIC COMMENTS - None

V. CONSENT AGENDA

| | |
|------------------|---|
| RESULT: | APPROVED [UNANIMOUS] |
| MOVER: | Kelley Johnson, Ward II |
| SECONDER: | Taneea Browning, Ward IV |
| AYES: | Williams, Olsen, Johnson, Thueson, Browning, Hernandez, Parsons |

A. Approval of May 23, 2019 City Council Minutes

B. Parks Commission Report May 2019

VI. ITEMS REMOVED FROM CONSENT AGENDA - None

VII. PUBLIC HEARING

A. Resolution No. _____, Accepting a Deed of Dedication for Land referred to as the Don and Flow Bohnert Family Farm Park from Twin Creeks Development Company, LLC.

Parks and Public Works Director Matt Samitore stated that the city has been working with the developer of Twin Creeks and the Johnson Family to construct the Don and

Minutes Acceptance: Minutes of Jun 13, 2019 7:00 PM (CONSENT AGENDA)

Flo Bohnert Family Farm Park. The City received a large grant from the Oregon Parks Department contingent on the first two phases being complete and a formal deed transfer to the City being recorded. The City has been working with the developer on the phases of the park in order to get completion and the deed transferred to the City.

Time is of the essence in accepting the dedication of this land, dedication is a condition of the grant award, which will expire soon if not accepted by the city. Although some of the details have not been completed staff recommends approving the Resolution accepting the property. The city has the authority to accept the dedication and will continue to work with the developer to remove the CCRs from the park and prior to recording the deed. The city will ensure receipt of the tax assessor's certification that all property taxes have been paid. If the deadline passes without the city accepting the deed Central Point would be in jeopardy of not being eligible for future grants from the Oregon Parks Department.

Kelley Johnson moved to approve Resolution No. 1581, accepting a deed of dedication for land referred to as the Don and Flo Bohnert Family Park from the Twin Creeks Development Company, LLC for Park purposes and directing the city manager to take such steps as may be required to complete the donation.

| | |
|------------------|---|
| RESULT: | APPROVED [UNANIMOUS] |
| MOVER: | Kelley Johnson, Ward II |
| SECONDER: | Tanea Browning, Ward IV |
| AYES: | Williams, Olsen, Johnson, Thueson, Browning, Hernandez, Parsons |

B. Resolution No. _____, A Resolution Certifying the Provision of Municipal Services by the City of Central Point, Oregon

Finance Director Steve Weber explained that this Resolution certified the provision of city services and is required by ORS in order to receive state cigarette, liquor, and highway taxes. We have budgeted \$3,673,710 from these resources over the next two years. This is an annual resolution.

Mayor Williams opened the public hearing. No one came forward and the public hearing was closed.

Brandon Thueson moved to approve Resolution No. 1582, A Resolution Certifying the Provision of Municipal Services by the City of Central Point, Oregon.

| | |
|------------------|---|
| RESULT: | APPROVED [UNANIMOUS] |
| MOVER: | Brandon Thueson, Ward III |
| SECONDER: | Rob Hernandez, At Large |
| AYES: | Williams, Olsen, Johnson, Thueson, Browning, Hernandez, Parsons |

C. Resolution No. _____, Receiving State Revenue Sharing Funds for Fiscal Year July 1, 2019 through June 30, 2020

Mr. Weber explained that this annual resolution is required by the State of Oregon

and must be adopted in order to receive state revenue sharing funds. The City has budgeted to receive \$465,200.

Mayor Williams opened the public hearing. No one came forward and the public hearing was closed.

Brandon Thueson moved to approve Resolution No. 1583, Receiving State Revenue Sharing Funds for Fiscal Year July 1, 2019 through June 30, 2020.

| | |
|------------------|---|
| RESULT: | APPROVED [UNANIMOUS] |
| MOVER: | Brandon Thueson, Ward III |
| SECONDER: | Taneea Browning, Ward IV |
| AYES: | Williams, Olsen, Johnson, Thueson, Browning, Hernandez, Parsons |

D. Resolution No. _____, Adopting the Budget; Make Appropriations and Levy Taxes for the Biennial Budget Period July 1, 2019 Through June 30, 2021

Mr. Webber explained the proposed resolution is to adopt the budget, make appropriations, and levy taxes for the 2019/2021 biennial budget period. Total budget to be appropriated is \$67,183,859 and the tax levy will be \$4.47 per thousand dollars of assessed value. The total budgeted property tax to be received during the biennial budget period is \$12,395,000.

Mayor Williams opened the public hearing. No one came forward and the public hearing was closed.

Brandon Thueson moved to approve Resolution No. 1584, Adopting the Budget; Make Appropriations and Levy Taxes for the Biennial Budget Period July 1, 2019 through June 30, 2021.

| | |
|------------------|---|
| RESULT: | APPROVED [UNANIMOUS] |
| MOVER: | Brandon Thueson, Ward III |
| SECONDER: | Michael Parsons, At Large |
| AYES: | Williams, Olsen, Johnson, Thueson, Browning, Hernandez, Parsons |

VIII. ORDINANCES, AND RESOLUTIONS

A. Resolution No. _____, A Resolution Approving Appointments and Adopting General Procedures for Fiscal Year 2019-2020

Mr. Weber stated that each fiscal year, the City Council considers a general procedures resolution which appoints specific individuals or firms to represent the City in the capacity of: City Attorney, City Engineer, City Auditor; Municipal Judge and Insurance Agent of Record. The general procedures regulate day to day processes such as council expenses, deposits, investing, transferring, and expending funds.

Kelley Johnson moved to approve Resolution No. 1585, A Resolution Approving Appointments and Adopting General Procedures for Fiscal Year

2019-2020.

| | |
|------------------|---|
| RESULT: | APPROVED [UNANIMOUS] |
| MOVER: | Kelley Johnson, Ward II |
| SECONDER: | Taneea Browning, Ward IV |
| AYES: | Williams, Olsen, Johnson, Thueson, Browning, Hernandez, Parsons |

B. Resolution No. _____, A Resolution to Close the High Tech Crime Unit Fund

Mr. Weber explained the background of the High Tech Crime Unit Fund (HTCU). In 2014 the participating agencies ceased operations of the unit. The City entered into an agreement with several agencies to distribute the funds. The 2017-2019 biennial budget approved a transfer of the remaining cash balance to the Reserve Fund for future police equipment needs.

Michael Parsons moved to approve Resolution No. 1586, A Resolution to close the High Tech Crime Unit Fund.

| | |
|------------------|---|
| RESULT: | APPROVED [UNANIMOUS] |
| MOVER: | Michael Parsons, At Large |
| SECONDER: | Taneea Browning, Ward IV |
| AYES: | Williams, Olsen, Johnson, Thueson, Browning, Hernandez, Parsons |

C. Resolution No. _____, Resolution No. _____, A Resolution Ratifying the Police Collective Bargaining Agreement and Authorizing the Mayor and City Manager to Sign the Agreement 2019-2023 Police Collective Bargaining Agreement (CBA)

Human Resource Director Elizabeth Simas explained the changes in the Police Collective Bargaining Agreement. There were no major changes except to the compensation plan. The increase to compensation has been included in the 2019-2021 budget. There was discussion regarding comparable jurisdictions, shift bidding changes, vacation accrual and payout ability. The agreement clarifies fitness reimbursement program options and updates to the HRA-VEBA accounts.

Kelley Johnson moved to approve Resolution No. 1587, A Resolution Ratifying the Police Collective Bargaining Agreement and Authorizing the Mayor and City Manager to Sign the 2019-2023 Police Collective Bargaining Agreement (CBA).

| | |
|------------------|---|
| RESULT: | APPROVED [UNANIMOUS] |
| MOVER: | Kelley Johnson, Ward II |
| SECONDER: | Taneea Browning, Ward IV |
| AYES: | Williams, Olsen, Johnson, Thueson, Browning, Hernandez, Parsons |

D. Resolution No. _____, Resolution No. _____, A Resolution Adopting the July 1, 2019 - June 30, 2020 Classification Pay Plan

Mrs. Simas explained that the revised pay plan reflects changes for all employee groups since the last pay plan was approved by Council in 2018. Part A has been

updated to show the addition of Step "G" per the collective bargaining agreement and the addition of a newly created position for Utility Laborer. Part B has been updated to reflect an increase of 3.25% per the Police Bargaining Unit. There were no other changes to Part B. Part C is the Management/Non-represented employees and there were no changes at this time.

Kelley Johnson moved to approve Resolution No. 1588, A Resolution Adopting the July 1, 2019 - June 30, 2020 Classification Pay Plan.

| | |
|------------------|---|
| RESULT: | APPROVED [UNANIMOUS] |
| MOVER: | Kelley Johnson, Ward II |
| SECONDER: | Taneea Browning, Ward IV |
| AYES: | Williams, Olsen, Johnson, Thueson, Browning, Hernandez, Parsons |

IX. BUSINESS

A. RVTB Bus Stop Shelter Location Change

Mr. Samitore explained a request from RVTB to move the bus stop on 2nd Street south 75 feet in front of US Bank. They have received a complaint about sight triangle issues. He stated that when a bus is stopped at the current location it could be a vision issue with cars in the opposite lane and vehicles going east on Manzanita Street. The move to the south may remove the site triangle issue but will cause the alley between US Bank and Human Bean to be blocked during loading and unloading.

Council members are concerned that blocking the bank driveway for 2 to 3 minutes twice an hour could cause traffic to back up onto Pine Street which would be a bigger issue than a sight triangle. Overall the Council is not in favor of moving the RVTB bus stop if it will be blocking the alley and entrance to the bank.

Mr. Samitore stated that he will relay the information to RVTB and they can look at other alternatives.

| | |
|----------------|----------------------------|
| RESULT: | FOR DISCUSSION ONLY |
|----------------|----------------------------|

B. Planning Commission Report

Community Development Director Tom Humphrey provided the June 4, 2019 Planning Commission report:

- The Commission held a public hearing to consider a modification to a condition of approval for the Smith Crossing Site Plan and Architectural Review. The condition addresses the timing of building permit issuance for buildings in Phase 2 of the development relative to the completion of the Twin Creeks Rail Crossing. The Commission considered and approved the request to allow the issuance of building permits for garages and four apartment buildings but not issue Certificates of Occupancy until the railroad crossing is complete and operational.
- The Commission held a public hearing to consider the 2019 Employment Buildable Lands Inventory. Land use activity and new population forecasts have necessitated updates to this 2013 document. This document is an inventory that is necessary to update the Economic Element of the Comprehensive Plan in

order to add more employment land to the UGB. The Commission recommended approval to the City Council.

- The Commission held a public hearing to consider an update of the Central Point Comprehensive Plan Economic Element based on a revised population forecast and new buildable lands information. In order to expand the UGB to include land in the CP-3 Urban Reserve Area we need to accommodate business growth and job creation. The Commission recommended approval to the City Council.

RESULT: FOR DISCUSSION ONLY

X. MAYOR'S REPORT

Mayors Williams reported that he attended:

- the Planning Commission meeting and testified against modifying the agreement for Smith Crossing.
- the Rodeo Sponsor dinner and Rodeo.
- the Medford Water Commission meeting. Their next meeting will be in Butte Falls.
- the 3rd Grade Field trip to City Hall. They held a mock Council meeting asking how to deal with barking dogs.
- a TRADCO meeting where they had a presentation on the greenway.
- The Medford Chamber Forum where Sheriff Sickler explained why Jackson County needs a new Jail.

XI. CITY MANAGER'S REPORT

City Manager Chris Clayton reported that:

- The City of Medford is talking about implementing a Public Safety Fee to help pay for issues around the Greenway. He will have a jurisdictional map available for City Council members in his weekly report.
- There are several articles predicting a recession in 2020.
- He attended the Medford Chamber Forum and the Jail presentation.
- Jackson Soil and Water Conservation will be reporting their progress along the burned area of the Greenway in Central Point at a future Council meeting.

XII. COUNCIL REPORTS

Council Member Mike Parsons reported that he attended:

- D.A.R.E. Graduation Central Point Elementary and D.A.R.E. day party at Twin Creeks Park.
- The Central Point Memorial Day Commemoration.
- The Rogue Pro Rodeo Sponsor Dinner and Rodeo.
- The Planning Commission meeting.
- The City Safety Fair.

- The Scenic Heights “getting to know you” event.

Council Member Tanea Browning reported that:

- She attended the D.A.R.E. Day at Twin Creeks.
- She attended the Memorial Day celebration at Don Jones Memorial.
- She attended the field trip at City Hall for Mae Richardson 3rd students.
- She attended Chamber forum on Monday.
- She attended the Scenic Heights Community BBQ on Wednesday night.
- She is heading to LOC Board meeting in Eugene tomorrow.
- DIRT is excited to host its first summer day camp of 2019 in two weeks at Skyrman Arboretum. Carl Skyrman has been very pleased with the activity at the home and has provided some very cool history about the family and property.
- CraterWorks will be hosting a Twin Creeks Crossing Party in late June.

Council Member Rob Hernandez attended the Medford Chamber Forum Lunch.

Council Member Brandon Thueson reported that:

- He attended the Adhoc Committee meeting for Dennis Richardson memorial. He is very excited for this project. It will be a great representation for Mr. Richardson.
- He will be out of town for the June 27th meeting. He and Councilman Olsen will be at a church function for the youth.

Council Member Kelley Johnson reported that she attended the:

- Rogue Pro Rodeo Sponsor dinner and Rodeo.
- Airport Advisory Committee meeting.

XIII. DEPARTMENT REPORTS

Human Resource Director Elizabeth Simas reported that she has been working on year end reports. The City held their Safety Fair and lunch last week. We had on sight fire extinguisher training.

Police Chief Kris Allison reported that:

- She has been on the road this week visiting different cities on behalf of the Oregon Police Chiefs Association.
- The Police Department is getting ready for the 4th of July.
- They have been working with United Way on suicide prevention.

- Greenway enforcement has been effective for Central Point over the last three years. They do a monthly sweep and offer any transients information where they can get assistance. We want people to feel safe in our section of the Greenway and having a police presence there is a big help.

Community Development Director Tom Humphrey reported that:

- He will be attending a meeting with Jackson County Development to work on scheduling joint meetings in regards to the UGB amendment process.
- The city will be hosting another Destination Boot Camp for this year. They have several business owners who are interested in attending.

XIV. EXECUTIVE SESSION - ORS 192.660 (2)(h) Legal Counsel

Brandon Thueson moved to Adjourn to Executive Session under ORS 192.660(2)(h) Legal Counsel. Tanea Browning seconded and the meeting was adjourned at 8:12 p.m.

The Council returned to regular session at 8:45 p.m.

XV. ADJOURNMENT

Mike Parsons moved to adjourn. Kelley Johnson seconded and the June 13, 2019 Council meeting was adjourned at 8:45 p.m.

The foregoing minutes of the June 13, 2019, Council meeting were approved by the City Council at its meeting of June 27, 2019.

Dated:

 Mayor Hank Williams

ATTEST:

 City Recorder



City of Central Point Staff Report to Council

ISSUE SUMMARY

| | | | |
|-------------------------|--|------------------------|--------------|
| TO: | City Council | DEPARTMENT: | Public Works |
| FROM: | Matt Samitore, Parks and Public Works Director | | |
| MEETING DATE: | June 27, 2019 | | |
| SUBJECT: | Street Closures for 4th of July | | |
| ACTION REQUIRED: | Consent Agenda Item | RECOMMENDATION: | Approval |

BACKGROUND INFORMATION: The City will be closing down multiple streets in the downtown for the annual 4th of July celebration. Several streets will have full closures throughout the morning of the 4th. After the parade concludes, only streets around Pfaff Park will be closed until the activities in the park are complete (mid afternoon).

There are no changes on the closures from last year's event.

FINANCIAL ANALYSIS: The overtime associated with the closure is in the 19-21FY Budget.

LEGAL ANALYSIS: N/A

COUNCIL GOALS/STRATEGIC PLAN ANALYSIS:

STAFF RECOMMENDATION: Approval of the temporary street closure for the 4th of July events.

RECOMMENDED MOTION: I move to approve the temporary street closures associated with the annual 4th of July celebration and parade.

ATTACHMENTS:

1. 4th July Parade & Fun Run Route 2019

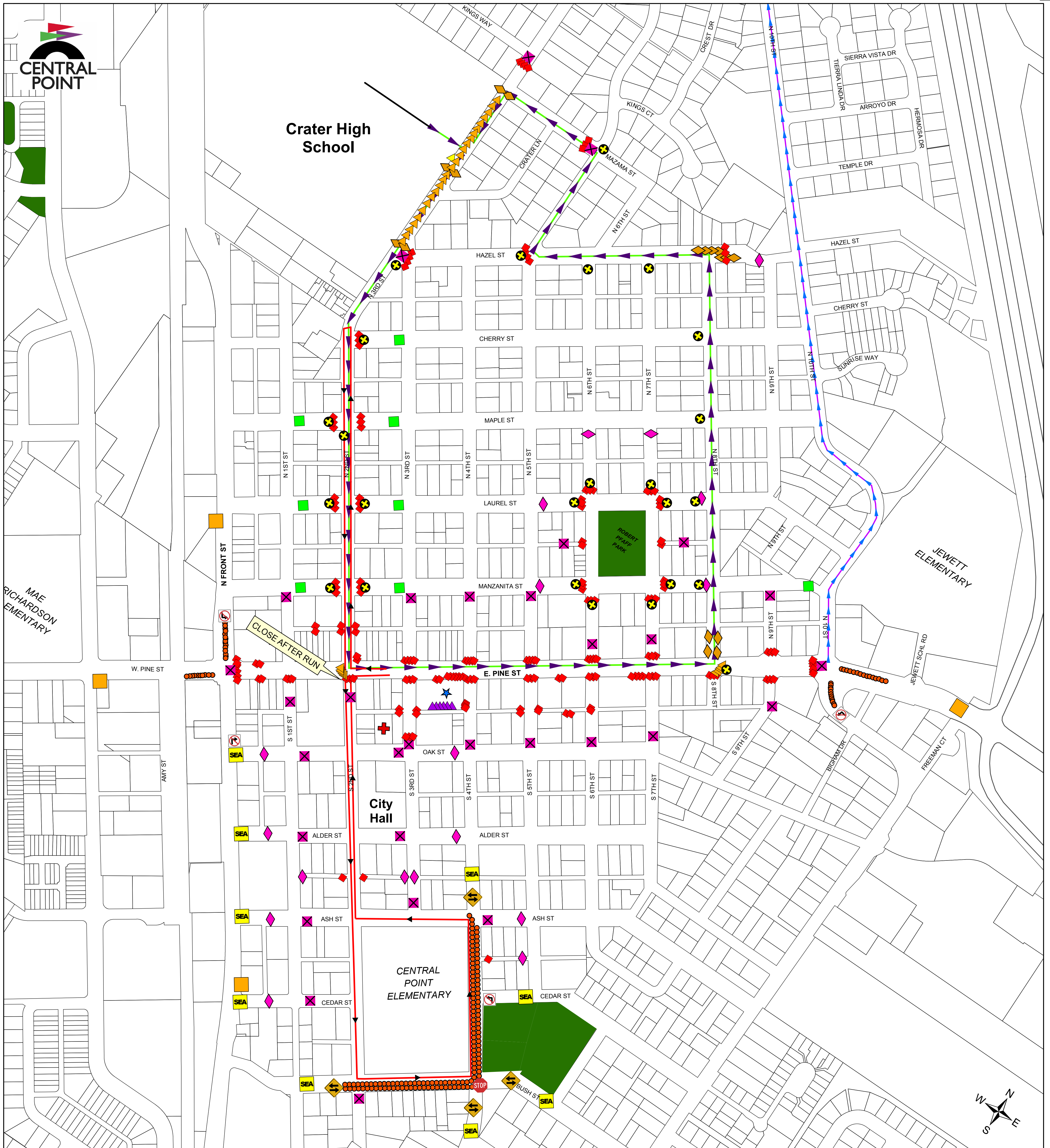

4th July Parade /Run 2018

- Type**
- 1 STOP
 - 4 Two Way Traffic
 - 9 Special Event Ahead

- 187 Cones
- 173 Barricade
- 6 Handicap Paking
- 35 Delineator
- 8 Local Traffic Only
- 18 Street Closed Ahead
- 31 Street Closed
- 17 No Parking Barricade
- 4 Reader Board
- 3 No Left Turn

- 2 No Right Turn
- Volunteer Post (25)
- 1 Caution Tape
- Command Post
- Triage

- Parade Route
- Detour Route
- Fun Run Route

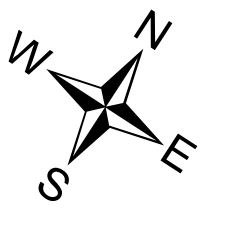

Attachment: 4th July Parade & Fun Run Route 2018 (1160) - Street Closures for 4th of July



City of Central Point **Staff Report to Council**

ISSUE SUMMARY

| | | | |
|-------------------------|---|------------------------|-----------------------|
| TO: | City Council | DEPARTMENT: | Community Development |
| FROM: | Stephanie Holtey, Principal Planner | | |
| MEETING DATE: | June 27, 2019 | | |
| SUBJECT: | First Reading - Ordinance Updating and Adopting the Employment Buildable Lands Inventory (BLI), an adjunct to the Land Use Element. | | |
| ACTION REQUIRED: | Public Hearing Ordinance 1st Reading | RECOMMENDATION: | Approval |

BACKGROUND INFORMATION:

On June 4, 2019, the Planning Commission considered the Employment Buildable Lands Inventory (BLI), an adjunct to the Land Use Element of the Central Point Comprehensive Plan, and conducted a duly noticed public hearing. No public testimony was received during the public hearing and the Planning Commission voted unanimously to forward a favorable recommendation to the City Council to approve the Employment BLI (Attachment “A”).

In accordance with OAR 660-024-0050(1), the Employment BLI tracks the availability of vacant and redevelopable employment (i.e. commercial, industrial, civic) lands likely to be developed over the next 20-years. Additionally it presents the distribution of buildable acres by parcel size and employment use category (i.e. retail, office, industrial land use). The Employment BLI is not a policy document in and of itself but is used in assessing the City’s economic opportunities in the Economic Element (CPA-19003).

Employment BLI Overview:

| Table 1. Employment Site Distribution: Vacant Acres vs. Vacant Parcels | | |
|---|-------------------------|---------------------------|
| Acreege Category | Vacant Acres | Vacant Parcels |
| Large Retail | 20% | 3% |
| Medium Retail | 13% | 9% |
| Small Retail | 9% | 43% |
| Large Office | 0% | 0% |
| Medium Office | 3% | 4% |

The City's urban area consists of 2,972 acres of which 633 (21%) are designated for employment use in the following categories:

- Commercial: 232.70 acres (8%)
- Industrial: 279.50 acres (9%)
- Civic: 121.05 acres (4%)

| | | |
|-------------------|-------------|-------------|
| Small Office | 0% | 1% |
| Large Industrial | 11% | 1% |
| Medium Industrial | 33% | 12% |
| Small Industrial | 12% | 27% |
| Total | 100% | 100% |

The Employment BLI tracks the development status of the City's employment lands by land use classification and zoning district. There are two basic types of buildable lands: 1) vacant land and 2) redevelopment land. Vacant lands have no improvement value and redevelopment lands are those lands that have experienced development but are likely to be converted to more intensive employment uses during the planning period due to present or expected market forces. Per the BLI, the City has 147 acres of buildable employment land, 31% of which is classified as redevelopment land. Of the City's buildable employment lands, the majority of the City's vacant acreage is in small size retail and industrial parcels. However these categories account for a significantly lower percentage of buildable vacant acreage.

FINANCIAL ANALYSIS:

The buildable lands inventory tracks the availability of land and does not generate additional cost to the City beyond the in-kind staff expenses, postage and legal notification costs included budgeted for Community Development.

LEGAL ANALYSIS:

The Employment BLI is a component of the Land Use Element of the Comprehensive Plan. Text amendments are considered "Major Amendments" per CPMC 17.96.300 and are subject to Type IV Legislative application procedures per CPMC 17.05.500. Conducting a second public hearing by the City Council is necessary and consistent with the requisite procedures to adopt changes to the forecast population.

COUNCIL GOALS/STRATEGIC PLAN ANALYSIS:

The City Council goal to provide managed growth and infrastructure is predicated on the ability of the City to forecast growth and the corresponding land and service needs over the long term relative to the ability of the City to accommodate growth within the current UGB. The 2019-3029 Employment BLI aligns with Council's goal by tracking the City's buildable lands, a prerequisite to, "Continually ensuring that planning and zoning review and regulations are consistent with comprehensive plans and vision."

STAFF RECOMMENDATION:

After receiving the staff report, open the public hearing to receive public input regarding the 2019-2039 Employment BLI. Close the public hearing and 1) forward to a second reading; 2) forward to a second reading with changes; or 3) deny the 2019-2039 Employment BLI.

RECOMMENDED MOTION:

Forward the Ordinance approving the 2019-2039 Employment BLI to a second reading at the July 11, 2019 City Council Meeting.

ATTACHMENTS:

1. Ordinance Approving the Employment BLI
2. Employment BLI (Final)

ORDINANCE NO. _____

AN ORDINANCE UPDATING AND ADOPTING THE EMPLOYMENT BUILDABLE LANDS INVENTORY (2019-2039), CENTRAL POINT COMPREHENSIVE PLAN LAND USE ELEMENT

Recitals:

- A. The City of Central Point (City) is authorized under Oregon Revised Statute (ORS) Chapter 197 to prepare, adopt and revise comprehensive plans and implementing ordinances consistent with the Statewide Land Use Planning Goals.
- B. The City has coordinated its planning efforts with the State in accordance with ORS 197.040(2)(e) and OAR 660-030-0060 to assure compliance with goals and compatibility with City and County Comprehensive Plans.
- C. Pursuant to authority granted by the City Charter and the ORS, the City has determined to update its Employment Buildable Lands Inventory, a component of the Land Element which was last updated in 2013 as part of the 2013 Economic Element update.
- D. Pursuant to the requirements set forth in CPMC Chapter 17.10.100 Amendments – Purpose and Chapter 17.96.010, Procedure, the City has initiated the amendments and conducted the following duly advertised public hearings to consider the proposed amendments:
 - a) Planning Commission hearing on June 4, 2019; and,
 - b) City Council hearing on June 27, 2019.

THE PEOPLE OF THE CITY OF CENTRAL POINT DO ORDAIN AS FOLLOWS:

Section 1. Based upon all the information received, the City Council adopts the Staff Reports and evidence which are incorporated herein by reference; determines that changing community conditions, needs and desires justify the amendments and hereby adopts the changes entirely.

Section 2. The Employment Buildable Lands Inventory, in the City Comprehensive Plan Land Use Element is hereby updated and adopted as set forth in Exhibit A –Comprehensive Employment Buildable Lands Inventor, 2019-2039 which is attached hereto and by this reference incorporated herein.

Section 3. The City Manager is directed to conduct post acknowledgement procedures defined in ORS 197.610 et seq. upon adoption of the Population Element.

Passed by the Council and signed by me in authentication of its passage this 11th day of July, 2019.

Mayor Hank Williams

ATTEST:

City Recorder

Attachment: Ordinance Approving the Employment BLI (1162 : Employment Buildable Lands Inventory)



Employment Buildable Lands Inventory (BLI)



2019 – 2039

Public Hearing Draft
June 4, 2019



Attachment: Employment BLI (Final) (1162 : Employment Buildable Lands Inventory)

City of Central Point

Table of Contents

- 1. INTRODUCTION 3
- 2. LAND USE CLASSIFICATIONS AND ZONING 4
- 3. EMPLOYMENT LAND INVENTORY..... 5
- 4. BUILDABLE EMPLOYMENT LAND INVENTORY 5
- 5. Employment Land Need..... 12
- 6. DEFINITIONS and METHODOLOGY..... 12
- APPENDIX "A" – Definitions..... 14
- APPENDIX "B" - Methodology for Calculation of Employment Buildable Land 17

Attachment: Employment BLI (Final) (1162 : Employment Buildable Lands Inventory)

1. INTRODUCTION

The purpose of the Employment Buildable Land Inventory (Employment BLI) is to maintain a record of the availability of buildable employment lands within the City’s urban area (Figure 1). The Employment BLI is prepared in accordance with OAR 660-24-0050(1) requiring that cities maintain a buildable lands inventory within the urban growth boundary sufficient to accommodate the employment needs for a 20-year planning period as determined in OAR 660-009-0015. For purposes of this Employment BLI the 20-year planning period is 2019 to 2039.

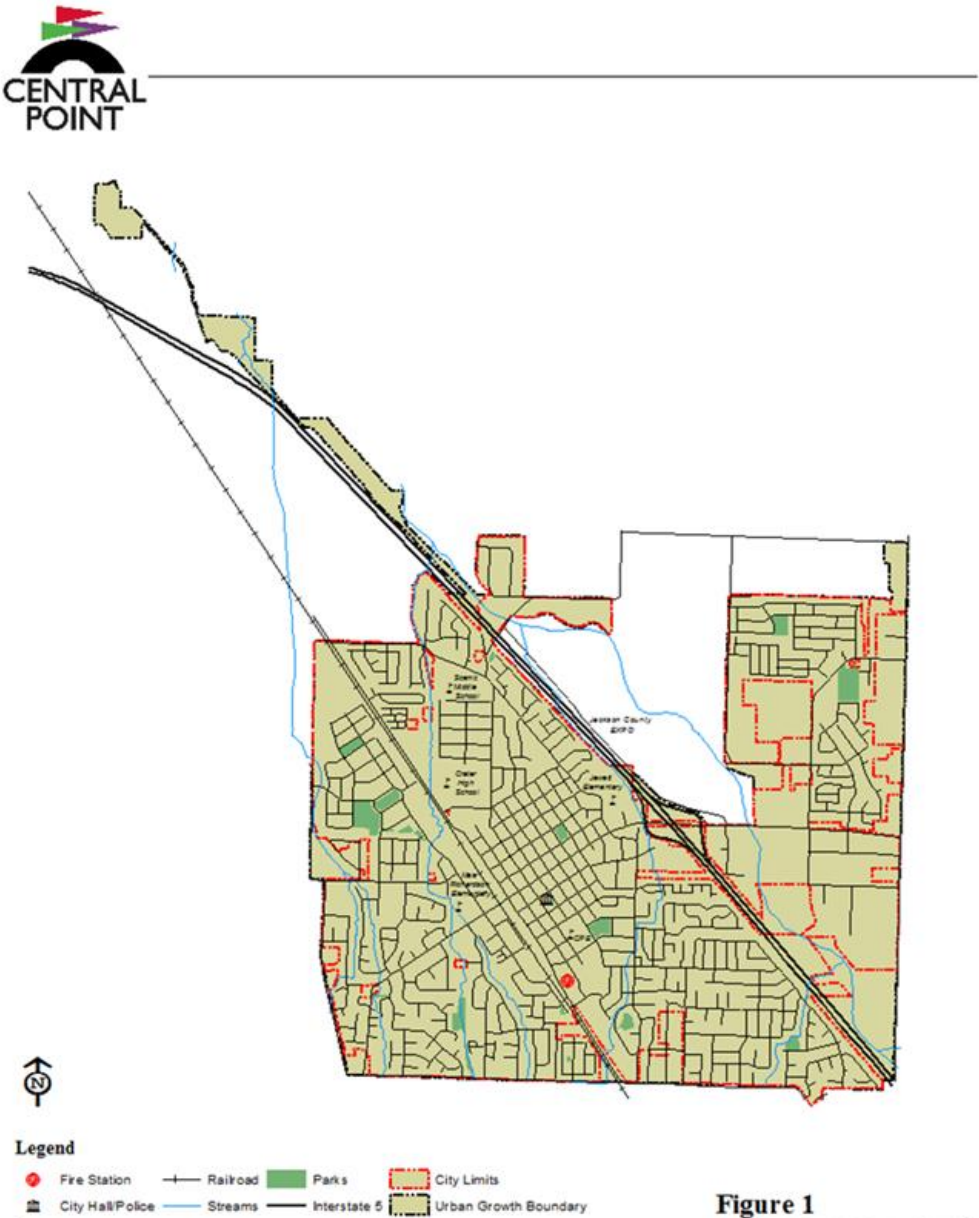

Figure 1
URBAN AREA, 2018

Attachment: Employment BLI (Final) (1162 : Employment Buildable Lands Inventory)

2019 – 2039 Employment BLI

By definition the Employment BLI is strictly a land inventory system. The Employment BLI is not a policy document. The Employment BLI is used by other Comprehensive Plan elements as a resource for the development and monitoring of policies related to economic development and land use.

The Employment BLI is considered a living document that is continually updated as development activity occurs and is entered into the City's BLI electronic data base (BLI2019).

2. LAND USE CLASSIFICATIONS AND ZONING

The Employment BLI maintains an accounting of all employment lands by land use classification and zoning (Table 1).

| Land Use Classification | Zoning District |
|------------------------------|-------------------------------------|
| Neighborhood Commercial (NC) | Neighborhood Commercial (NC) |
| | Commercial Medical (C-2(M)) |
| Employment Commercial (EC) | Tourist & Office Professional (C-4) |
| | Employment Commercial (EC) |
| General Commercial (GC) | Thoroughfare Commercial (C-5) |
| | General Commercial (GC) |
| Light Industrial (Lind) | Industrial (M-1) |
| General Industrial (Hind) | Industrial General (M-2) |
| Civic | Civic |

The City's Comprehensive Plan contains five (5) employment land use classifications (Table 2). The employment land use classifications are supported by nine (9) employment zoning districts (Table 3). The Land Use Classifications and Zoning districts are defined and mapped in the City's Land Use Element.

**Table 2. City of Central Point
Employment Land Inventory by Comprehensive Plan Designation**

| Comprehensive Plan Designation | Total City Acres | Total UGB Acres | Total Urban Acres |
|--------------------------------|------------------|-----------------|-------------------|
| NC | 2.64 | 7.83 | 10.47 |
| EC | 154.42 | 11.68 | 166.10 |
| GC | 56.13 | - | 56.13 |
| TOTAL COMMERCIAL | 213.19 | 19.51 | 232.70 |
| LInd | 78.57 | 102.37 | 180.95 |
| HInd | 39.67 | 58.89 | 98.56 |
| TOTAL INDUSTRIAL | 118.24 | 161.26 | 279.50 |
| Civic | 120.91 | 0.14 | 121.05 |
| TOTAL CIVIC | 120.91 | 0.14 | 121.05 |
| GRAND TOTAL | 452.35 | 180.90 | 633.25 |

Source: City of Central Point 2019 BLI

2019 – 2039 Employment BLI

3. EMPLOYMENT LAND INVENTORY

As of December 31, 2018, the City of Central Point’s urban area contained a total of 633 gross acres (Table 2 and 3) of employment designated land, representing 21% of the City’s total land inventory. The City’s Employment lands were distributed amongst three basic land use categories; Commercial (8%), Industrial (9%), and Civic (4%) lands.

**Table 3. City of Central Point
Employment Land Inventory by Zoning District**

| Comprehensive Plan Designation | Total City Acres | Total UGB Acres | Total Urban Acres |
|--------------------------------|------------------|-----------------|-------------------|
| C-2(m) | 12.08 | - | 12.08 |
| CN | 2.64 | 7.83 | 10.47 |
| C-4 | 100.47 | 8.48 | 108.95 |
| C-5 | 12.49 | 3.19 | 15.69 |
| EC | 29.39 | - | 29.39 |
| GC | 56.13 | - | 56.13 |
| TOTAL COMMERCIAL | 213.19 | 19.51 | 232.70 |
| M-1 | 78.57 | 102.37 | 180.95 |
| M-2 | 39.67 | 58.89 | 98.56 |
| TOTAL INDUSTRIAL | 118.24 | 161.26 | 279.50 |
| Civic | 120.91 | 0.14 | 121.05 |
| TOTAL CIVIC | 120.91 | 0.14 | 121.05 |
| GRAND TOTAL | 452.35 | 180.90 | 633.25 |

Source: City of Central Point 2019 BLI

4. BUILDABLE EMPLOYMENT LAND INVENTORY

The term “Buildable Land” is typically reserved for residential use¹. However, for purposes of consistency the term “Buildable Land” is applied in this BLI for purposes of identifying and tracking the City’s Employment Land inventory.

Within the City’s urban area, there are approximately 633 acres of employment land distributed over five (5) employment land use classifications and nine (9) employment zoning districts. Approximately 147 acres (23%) of the City’s total employment land is considered net buildable acres. Table 4 and 5 identify the distribution of the employment net buildable land by vacant land type (vacant, constrained, and redevelopment), and total buildable acres. Figure 2 illustrates the geographic distribution of the City’s employment buildable vacant land inventory (May 7, 2019).

In calculating the Employment Net Buildable Lands a determination must be made that the buildable lands are suitable, available and necessary (OAR 660-009-0005(2)) for development throughout the 20-year planning period. There are two basic classifications of buildable employment land:

¹ OAR 660-024-0010(1).

2019 – 2039 Employment BLI

- a. Vacant Land –Lands on which there are no improvements. Infrastructure is available within the 20-year planning period.
- b. Redevelopable Land –Lands on which development has already occurred but on which, due to present or expected market forces, there exists the strong likelihood that existing development will be converted to more intensive employment uses during the planning period.

4.2 Total Net Buildable Acres. Tables 3 and 4 identify the Total Net Buildable Acres of employment land by land use designation and zoning. Approximately 23% of the City’s employment lands are identified as buildable. A large percentage (31%) of the City’s net buildable acreage is classified as redevelopment land.

Table 4. City of Central Point
Net Buildable Employment Land Inventory by Comprehensive Plan Designation

| Comprehensive Plan Designation | Total City Acres | Total UGB Acres | Total Urban Acres | Total Vacant Acres | Constrained Acres | Gross Buildable Vacant Acres | Public Facility Acres | Net Buildable Vacant Acres | Redevelopable Acres | Total Net Buildable Acres |
|--------------------------------|------------------|-----------------|-------------------|--------------------|-------------------|------------------------------|-----------------------|----------------------------|---------------------|---------------------------|
| NC | 2.64 | 7.83 | 10.47 | 0.24 | - | 0.24 | 0.06 | 0.18 | 1.51 | 1.70 |
| EC | 154.42 | 11.68 | 166.10 | 61.91 | 2.44 | 59.47 | 14.87 | 44.60 | 8.43 | 53.04 |
| GC | 56.13 | - | 56.13 | 8.23 | - | 8.23 | 2.06 | 6.17 | 0.40 | 6.57 |
| TOTAL COMMERCIAL | 213.19 | 19.51 | 232.70 | 70.38 | 2.44 | 67.94 | 16.99 | 50.96 | 10.35 | 61.31 |
| Lnd | 78.57 | 102.37 | 180.95 | 69.18 | 14.97 | 54.21 | 13.55 | 40.66 | 34.31 | 74.97 |
| Hnd | 39.67 | 58.89 | 98.56 | 18.49 | 5.33 | 13.17 | 3.29 | 9.88 | 1.87 | 11.75 |
| TOTAL INDUSTRIAL | 118.24 | 161.26 | 279.50 | 87.67 | 20.30 | 67.38 | 16.84 | 50.53 | 36.18 | 86.72 |
| Civic | 120.91 | 0.14 | 121.05 | - | - | - | - | - | - | - |
| TOTAL CIVIC | 120.91 | 0.14 | 121.05 | - | - | - | - | - | - | - |
| GRAND TOTAL | 452.35 | 180.90 | 633.25 | 158.06 | 22.74 | 135.32 | 33.83 | 101.49 | 46.54 | 148.03 |

Source: City of Central Point 2019 BLI

Table 5. City of Central Point
Net Buildable Employment Land Inventory by Zoning District

| Comprehensive Plan Designation | Total City Acres | Total UGB Acres | Total Urban Acres | Total Vacant Acres | Constrained Acres | Gross Buildable Vacant Acres | Public Facility Acres | Net Buildable Vacant Acres | Redevelopable Acres | Total Net Buildable Acres |
|--------------------------------|------------------|-----------------|-------------------|--------------------|-------------------|------------------------------|-----------------------|----------------------------|---------------------|---------------------------|
| C-2(m) | 12.08 | - | 12.08 | - | - | - | - | - | 0.12 | 0.12 |
| CN | 2.64 | 7.83 | 10.47 | 0.24 | - | 0.24 | 0.06 | 0.18 | 1.51 | 1.70 |
| C-4 | 100.47 | 8.48 | 108.95 | 45.71 | 1.41 | 44.30 | 11.07 | 33.22 | 5.12 | 38.34 |
| C-5 | 12.49 | 3.19 | 15.69 | 11.07 | - | 11.07 | 2.77 | 8.30 | 3.19 | 11.50 |
| EC | 29.39 | - | 29.39 | 5.13 | 1.03 | 4.10 | 1.03 | 3.08 | - | 3.08 |
| GC | 56.13 | - | 56.13 | 8.23 | - | 8.23 | 2.06 | 6.17 | 0.40 | 6.57 |
| TOTAL COMMERCIAL | 213.19 | 19.51 | 232.70 | 70.38 | 2.44 | 67.94 | 16.99 | 50.96 | 10.35 | 61.31 |
| M-1 | 78.57 | 102.37 | 180.95 | 69.18 | 14.97 | 54.21 | 13.55 | 40.66 | 34.31 | 74.97 |
| M-2 | 39.67 | 58.89 | 98.56 | 18.49 | 5.33 | 13.17 | 3.29 | 9.88 | 1.87 | 11.75 |
| TOTAL INDUSTRIAL | 118.24 | 161.26 | 279.50 | 87.67 | 20.30 | 67.38 | 16.84 | 50.53 | 36.18 | 86.72 |
| Civic | 120.91 | 0.14 | 121.05 | - | - | - | - | - | - | - |
| TOTAL CIVIC | 120.91 | 0.14 | 121.05 | - | - | - | - | - | - | - |
| GRAND TOTAL | 452.35 | 180.90 | 633.25 | 158.06 | 22.74 | 135.32 | 33.83 | 101.49 | 46.54 | 148.03 |

Source: City of Central Point 2019 BLI

4.3 Parcel Size Distribution. An important consideration in considering a city’s employment land inventory is parcel size. This is particularly true for industrial property. Tables 6 and 7 identify the distribution of the City’s employment lands by size (Large, Medium, and Small) within three general employment categories (Retail, Office, and Industry). Tables 8 and 9 illustrate the same information for vacant employment lands.

Figure 3 summarizes the parcel and acreage distribution for the vacant employment lands. As illustrated in Table 3 the City’s inventory of vacant employment land is concentrated in the large retail and large industrial parcel category (31%), but only represent 4% of the total number of vacant employment parcels.

Figure 3. Vacant Acreage by Percentage Distribution and Size

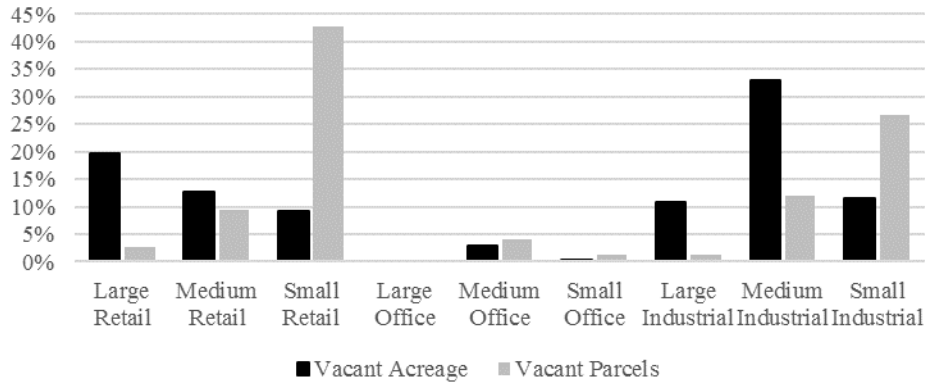

It needs to be noted that the Office category is represented by the EmpCom land use classification. With respect to office use all of the Cities commercial land use classifications allow office uses. The EmpCom classification focuses on office uses, however; the EmpCom allows retail uses.

2019 – 2039 Employment BLI

**Table 6. City of Central Point
Employment Land Inventory by Comprehensive Plan Designation
Acres, and Size Classification**

| Land Use Designation | CITY | | | UGB | | |
|--|--------------|-------------------|---------------------|--------------|-------------------|---------------------|
| | Acres | Number of Parcels | Average Parcel Size | Acres | Number of Parcels | Average Parcel Size |
| RETAIL | | | | | | |
| Large Retail (8 plus acres) | | | | | | |
| NC | 0.0 | 0 | 0.0 | 0.0 | 0 | 0.0 |
| EC | 30.9 | 2 | 15.5 | 0.0 | 0 | 0.0 |
| GC | 0.0 | 0 | 0.0 | 0.0 | 0 | 0.0 |
| Subtotal Large Retail | 30.9 | 2 | 15.5 | 0.0 | 0 | 0.0 |
| Medium Retail (2 to 7.99 acres) | | | | | | |
| NC | 0.0 | 0 | 0.0 | 0.0 | 0 | 0.0 |
| EC | 52.0 | 15 | 3.5 | 9.2 | 2 | 4.6 |
| GC | 17.7 | 7 | 2.5 | 0.0 | 0 | 0.0 |
| Subtotal Medium Retail | 69.7 | 22 | 3.2 | 9.2 | 2 | 4.6 |
| Small Retail (<2 acres) | | | | | | |
| NC | 2.6 | 4 | 0.7 | 7.8 | 10 | 0.8 |
| EC | 71.5 | 180 | 0.4 | 2.5 | 2 | 1.3 |
| GC | 38.5 | 100 | 0.4 | 0.0 | 0 | 0.0 |
| Subtotal Small Retail | 112.6 | 284 | 0.4 | 10.4 | 12 | 0.9 |
| Retail Subtotal | 213.2 | 308 | | 19.5 | 14 | |
| INDUSTRIAL | | | | | | |
| Large Industrial (>= 15 acres) | | | | | | |
| LInd | 17.3 | 1 | 17.3 | 0.0 | 0 | 0.0 |
| HInd | 20.2 | 1 | 20.2 | 0.0 | 0 | 0.0 |
| Subtotal Large Industrial | 37.5 | 2 | | 0.0 | 0 | |
| Medium Industrial (3 - 14.99 acres) | | | | | | |
| LInd | 34.9 | 6 | 5.8 | 48.7 | 10 | 4.9 |
| HInd | 19.4 | 4 | 4.9 | 56.5 | 7 | 8.1 |
| Subtotal Medium Industri | 54.3 | 10 | 5.4 | 105.2 | 17.0 | |
| Small Industrial (<3 acres) | | | | | | |
| LInd | 26.4 | 22 | 1.2 | 53.7 | 57 | 0.94 |
| HInd | 0.0 | 0 | 0.0 | 2.4 | 2 | 1.18 |
| Subtotal Small Industrial | 26.4 | 22 | 1.2 | 56.0 | 59 | |
| Industrial Subtotal | 118.2 | 34 | | 161.3 | 76 | |
| Grand Total | 331.4 | 342 | | 180.8 | 90 | |

Source: City of Central Point 2019 BLI

Attachment: Employment BLI (Final) (1162 : Employment Buildable Lands Inventory)

2019 – 2039 Employment BLI

Table 7. City of Central Point
Employment Land Inventory by Zoning District,
Acres, and Size Classification

| Land Use Designation | CITY | | | UGB | | |
|--|--------------|-------------------|---------------------|---------------|-------------------|---------------------|
| | Acres | Number of Parcels | Average Parcel Size | Acres | Number of Parcels | Average Parcel Size |
| RETAIL | | | | | | |
| Large Retail (8 or more acres) | | | | | | |
| C-2(m) | 0.0 | 0 | 0.0 | 0.0 | 0 | 0.0 |
| CN | 0.0 | 0 | 0.0 | 0.0 | 0 | 0.0 |
| C-4 | 30.9 | 2 | 15.5 | 0.0 | 0 | 0.0 |
| C-5 | 0.0 | 0 | 0.0 | 0.0 | 0 | 0.0 |
| GC | 0.0 | 0 | 0.0 | 0.0 | 0 | 0.0 |
| Subtotal Large Retail | 30.9 | 2 | 15.5 | 0.0 | 0 | 0.0 |
| Medium Retail (2 to 7.99 acres) | | | | | | |
| C-2(m) | 3.5 | 1 | 3.5 | 0.0 | 0 | 0.0 |
| CN | 0.0 | 0 | 0.0 | 0.0 | 0 | 0.0 |
| C-4 | 31.7 | 9 | 3.5 | 6.0 | 1 | 6.0 |
| C-5 | 9.9 | 3 | 3.3 | 3.2 | 1 | 3.2 |
| GC | 17.7 | 7 | 2.5 | 0.0 | 0 | 0.0 |
| Subtotal Medium Retail | 62.8 | 20 | 3.1 | 9.2 | 2 | 4.6 |
| Small Retail (<2 acres) | | | | | | |
| C-2(m) | 8.6 | 32 | 0.3 | 0.0 | 0 | 0.0 |
| CN | 2.6 | 4 | 0.7 | 7.8 | 10 | 0.8 |
| C-4 | 37.8 | 81 | 0.5 | 2.5 | 2 | 1.3 |
| C-5 | 2.6 | 2 | 1.3 | 0.0 | 0 | 0.0 |
| GC | 38.5 | 100 | 0.4 | 0.0 | 0 | 0.0 |
| Subtotal Small Retail | 90.1 | 219 | 0.4 | 10.4 | 12 | 0.9 |
| Retail Subtotal | 183.8 | 241 | | 19.5 | 14 | |
| Large Office (>= 3.5 acres) | | | | | | |
| EC | 3.6 | 1 | 3.6 | 0.0 | 0 | 0.0 |
| Medium Office (1 - 3.49 acres) | | | | | | |
| EC | 12.2 | 7 | 1.7 | 0.0 | 0 | 0.0 |
| Small Office (<1 acre) | | | | | | |
| EC | 13.6 | 59 | 0.2 | 0.0 | 0 | 0.0 |
| Office Subtotal | 29.4 | 67 | | 0 | 0 | |
| Large Industrial (>= 15 acres) | | | | | | |
| M-1 | 17.3 | 1 | 17.3 | 0.0 | 0 | 0.0 |
| M-2 | 20.2 | 1 | 20.2 | 0.0 | 0 | 0.0 |
| Subtotal Large Industrial | 37.5 | 2 | | 0.0 | 0 | |
| Medium Industrial (3 - 14.99 acres) | | | | | | |
| M-1 | 34.9 | 6 | 5.8 | 48.7 | 10 | 4.9 |
| M-2 | 19.4 | 4 | 4.9 | 56.5 | 7 | 8.1 |
| Subtotal Medium Industrial | 54.3 | 10 | 5.4 | 105.2 | 17.0 | |
| Small Industrial (<3 acres) | | | | | | |
| M-1 | 26.4 | 22 | 1.2 | 53.7 | 57 | 0.94 |
| M-2 | 0.0 | 0 | 0.0 | 2.4 | 2 | 1.18 |
| Subtotal Small Industrial | 26.4 | 22 | 1.2 | 56.0 | 59 | |
| Industrial Subtotal | 118.2 | 34 | | 161.3 | 76 | |
| Grand Total | 331.4 | 342 | | 180.77 | 90 | |

Source: City of Central Point 2019 BLI

2019 – 2039 Employment BLI

**Table 8. City of Central Point
Vacant Employment Land Inventory by Comprehensive Plan Designation
Acres, and Size Classification**

| Land Use Designation | CITY | | | UGB | | |
|--|--------------|-------------------|---------------------|--------------|-------------------|---------------------|
| | Acres | Number of Parcels | Average Parcel Size | Acres | Number of Parcels | Average Parcel Size |
| RETAIL | | | | | | |
| Large Retail (8 plus acres) | | | | | | |
| NC | 0.0 | 0 | 0.0 | 0.0 | 0 | 0.0 |
| EC | 30.9 | 2 | 15.5 | 0.0 | 0 | 0.0 |
| GC | 0.0 | 0 | 0.0 | 0.0 | 0 | 0.0 |
| Subtotal Large Retail | 30.9 | 2 | 15.5 | 0.0 | 0 | 0.0 |
| Medium Retail (2 to 7.99 acres) | | | | | | |
| NC | 0.0 | 0 | 0.0 | 0.0 | 0 | 0.0 |
| EC | 17.1 | 6 | 2.8 | 0.0 | 0 | 0.0 |
| GC | 2.9 | 1 | 2.9 | 0.0 | 0 | 0.0 |
| Subtotal Medium Retail | 20.0 | 7 | 2.9 | 0.0 | 0 | 0.0 |
| Small Retail (<2 acres) | | | | | | |
| NC | 0.0 | 0 | 0.0 | 0.2 | 1 | 0.2 |
| EC | 13.9 | 21 | 0.7 | 0.0 | 0 | 0.0 |
| GC | 5.3 | 14 | 0.4 | 0.0 | 0 | 0.0 |
| Subtotal Small Retail | 19.2 | 35 | 0.5 | 0.2 | 1 | 0.2 |
| Retail Subtotal | 70.1 | 44 | | 0.2 | 1 | |
| INDUSTRIAL | | | | | | |
| Large Industrial (>= 15 acres) | | | | | | |
| LInd | 17.3 | 1 | 17.3 | 0.0 | 0 | 0.0 |
| HInd | 0.0 | 0 | 0.0 | 0.0 | 0 | 0.0 |
| Subtotal Large Industrial | 17.3 | 1 | | 0.0 | 0 | |
| Medium Industrial (3 - 14.99 acres) | | | | | | |
| LInd | 18.1 | 3 | 6.0 | 16.0 | 2 | 8.0 |
| HInd | 8.7 | 2 | 4.4 | 9.3 | 2 | 4.6 |
| Subtotal Medium Industrial | 26.8 | 5 | 5.4 | 25.2 | 4.0 | |
| Small Industrial (<3 acres) | | | | | | |
| LInd | 15.1 | 14 | 1.1 | 2.7 | 5 | 0.54 |
| HInd | 0.0 | 0 | 0.0 | 0.5 | 1 | 0.49 |
| Subtotal Small Industrial | 15.1 | 14 | 1.1 | 3.2 | 6 | |
| Industrial Subtotal | 59.3 | 20 | | 28.4 | 10 | |
| Grand Total | 129.4 | 64 | | 28.66 | 11 | |

Source: City of Central Point 2019 BLI

Attachment: Employment BLI (Final) (1162 : Employment Buildable Lands Inventory)

2019 – 2039 Employment BLI

**Table 9. City of Central Point
Vacant Employment Land Inventory by Zoning District,
Acres, and Size Classification**

| Land Use Designation | CITY | | | UGB | | |
|--|--------------|-------------------|---------------------|--------------|-------------------|---------------------|
| | Acres | Number of Parcels | Average Parcel Size | Acres | Number of Parcels | Average Parcel Size |
| RETAIL | | | | | | |
| Large Retail (8 plus acres) | | | | | | |
| C-2(m) | 0.0 | 0 | 0.0 | 0.0 | 0 | 0.0 |
| CN | 0.0 | 0 | 0.0 | 0.0 | 0 | 0.0 |
| C-4 | 30.9 | 2 | 15.5 | 0.0 | 0 | 0.0 |
| C-5 | 0.0 | 0 | 0.0 | 0.0 | 0 | 0.0 |
| GC | 0.0 | 0 | 0.0 | 0.0 | 0 | 0.0 |
| Subtotal Large Retail | 30.9 | 2 | 15.5 | 0.0 | 0 | 0.0 |
| Medium Retail (2 to 7.99 acres) | | | | | | |
| C-2(m) | 0.0 | 0 | 0.0 | 0.0 | 0 | 0.0 |
| CN | 0.0 | 0 | 0.0 | 0.0 | 0 | 0.0 |
| C-4 | 7.2 | 3 | 2.4 | 0.0 | 0 | 0.0 |
| C-5 | 9.9 | 3 | 3.3 | 0.0 | 0 | 0.0 |
| GC | 2.9 | 1 | 2.9 | 0.0 | 0 | 0.0 |
| Subtotal Medium Retail | 20.0 | 7 | 2.9 | 0.0 | 0 | 0.0 |
| Small Retail (<2 acres) | | | | | | |
| C-2(m) | 0.0 | 0 | 0.0 | 0.0 | 0 | 0.0 |
| CN | 0.0 | 0 | 0.0 | 0.2 | 1 | 0.2 |
| C-4 | 7.6 | 16 | 0.5 | 0.0 | 0 | 0.0 |
| C-5 | 1.2 | 1 | 1.2 | 0.0 | 0 | 0.0 |
| GC | 5.3 | 14 | 0.4 | 0.0 | 0 | 0.0 |
| Subtotal Small Retail | 14.1 | 31 | 0.5 | 0.2 | 1 | 0.2 |
| Retail Subtotal | 65.0 | 40 | | 0.2 | 1 | |
| OFFICE | | | | | | |
| Large Office (>= 3.5 acres) | | | | | | |
| EC | 0.0 | 0 | 0.0 | 0.0 | 0 | 0.0 |
| Medium Office (1 - 3.49 acres) | | | | | | |
| EC | 4.6 | 3 | 1.5 | 0.0 | 0 | 0.0 |
| Small Office (<1 acre) | | | | | | |
| EC | 0.5 | 1 | 0.5 | 0.0 | 0 | 0.0 |
| Office Subtotal | 5.1 | 4 | | 0 | 0 | |
| INDUSTRIAL | | | | | | |
| Large Industrial (>= 15 acres) | | | | | | |
| M-1 | 17.3 | 1 | 17.3 | 0.0 | 0 | 0.0 |
| M-2 | 0.0 | 0 | 0.0 | 0.0 | 0 | 0.0 |
| Subtotal Large Industrial | 17.3 | 1 | | 0.0 | 0 | |
| Medium Industrial (3 - 14.99 acres) | | | | | | |
| M-1 | 18.1 | 3 | 6.0 | 16.0 | 2 | 8.0 |
| M-2 | 8.7 | 2 | 4.4 | 9.3 | 2 | 4.6 |
| Subtotal Medium Industrial | 26.8 | 5 | 5.4 | 25.2 | 4.0 | |
| Small Industrial (<3 acres) | | | | | | |
| M-1 | 15.1 | 14 | 1.1 | 2.7 | 5 | 0.54 |
| M-2 | 0.0 | 0 | 0.0 | 0.5 | 1 | 0.49 |
| Subtotal Small Industrial | 15.1 | 14 | 1.1 | 3.2 | 6 | |
| Industrial Subtotal | 59.3 | 20 | | 28.4 | 10 | |
| Grand Total | 129.4 | 64 | | 28.66 | 11 | |

Source: City of Central Point 2019 BLI

Page 11 of 18

Attachment: Employment BLI (Final) (1162 : Employment Buildable Lands Inventory)

5. Employment Land Need

As previously noted the primary function of the BLI is to assist in the identification of buildable land needs during a 20-year planning period. The BLI does not determine the City's quantitative need for employment land, it only identifies the City's current employment land inventory. The determination of the City's need for employment land is the function of the Economic Element. As noted earlier the BLI is a living document that changes as changes occur in employment development activity and policy.

6. DEFINITIONS and METHODOLOGY

To maintain consistency in the maintenance of the BLI the definitions and methodology used in preparing the Employment BLI are presented in Appendix "A" – Definitions and Appendix "B" – Methodology.

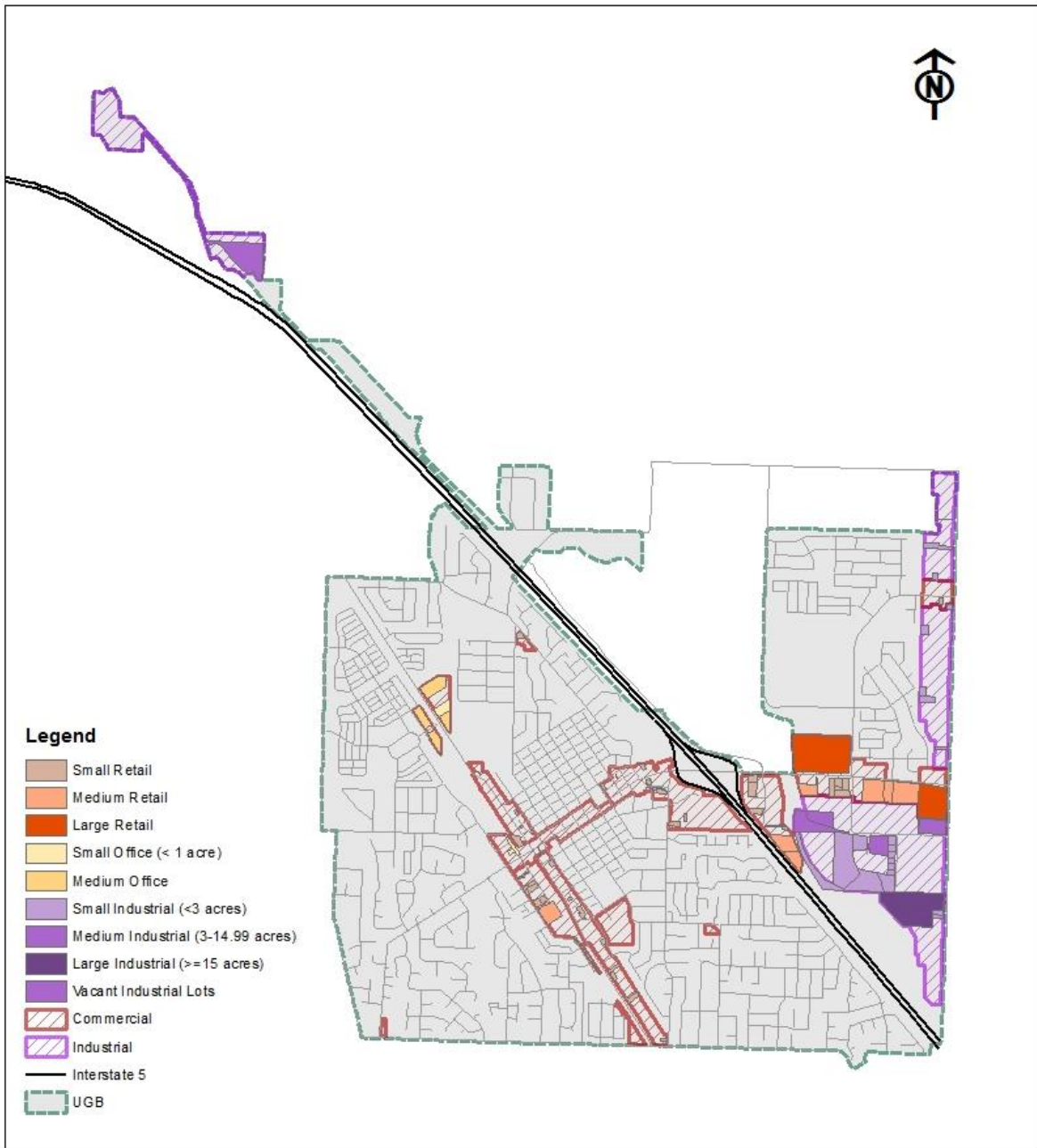

Figure 2. Employment Buildable Lands Inventory

Vacant Land by Land Use Type

Attachment: Employment BLI (Final) (1162 : Employment Buildable Lands Inventory)

2019 – 2039 Employment BLI

APPENDIX “A” – Definitions

The 2019 BLI was last updated December 30, 2018. The following definitions are used in preparing and maintain the residential BLI.

(1) **“Buildable Land, Employment”** means Employment designated lots or parcels within the City’s urban area, including vacant and developed lots or parcels likely to be redeveloped that are suitable, available and necessary for employment uses (OAR 660-009-0005(1)). Land is generally considered “suitable and available” unless it:

1. Is severely constrained by natural hazards as determined under Statewide Planning Goal 7;
2. Is subject to natural resource protection measures determined under Statewide Planning Goals 5, 6, 15, 16, 17 or 18;
3. Has slopes of 25 percent or greater;
4. Is within the 100-year flood plain; or
5. Cannot be provided with public facilities.

(2) **“Redevelopment Land, Employment”** means non-vacant land that is likely to be redeveloped during the planning period. For purposes of this BLI the term Employment Redevelopment Land is employment land that has a Land (L) to Improvement (I) ratio of less than 1 and is occupied by a single-family detached residence. The L:I Ratio is the ratio between the real market value of land and the real market value of improvements as measured by taking the real improvement value of a parcel divided by the real land value based on the Jackson County Assessor records.

(3) **“Development Constraints”** means factors that temporarily or permanently limit or prevent the use of land for economic development. Development constraints include, but are not limited to, wetlands, environmentally sensitive areas such as habitat, environmental contamination, slope, topography, cultural and archeological resources, infrastructure deficiencies, parcel fragmentation, or natural hazard areas (OAR 660-009-0005)(2).

(4) **“Industrial Use”** means employment activities generating income from the production, handling or distribution of goods. Industrial uses include, but are not limited to: manufacturing; assembly; fabrication; processing; storage; logistics; warehousing; importation; distribution and transshipment; and research and development. Industrial uses may have unique land, infrastructure, energy, and transportation requirements. Industrial uses may have external impacts on surrounding uses and may cluster in traditional or new industrial areas where they are segregated from other non-industrial activities (OAR 660-009-0005(3)).

(5) **“Other Employment Use”** means all non-industrial employment activities including the widest range of retail, wholesale, service, non-profit, business headquarters, administrative and governmental employment activities that are accommodated in retail, office and flexible building types. Other employment uses also include employment activities of an entity or organization that serves the medical, educational, social service, recreation and security needs of the community typically in large buildings or multi-building campuses (OAR-009-0005)(6).

(5) **“Planning Area”** means the area within an existing or proposed urban growth boundary. Cities and counties with urban growth management agreements must address the urban land governed by their

2019 – 2039 Employment BLI

respective plans as specified in the urban growth management agreement for the affected area (OAR 660-009-0005(7)).

(6) “Prime Industrial Land” means land suited for traded-sector industries as well as other industrial uses providing support to traded-sector industries. Prime industrial lands possess site characteristics that are difficult or impossible to replicate in the planning area or region. Prime industrial lands have necessary access to transportation and freight infrastructure, including, but not limited to, rail, marine ports and airports, multimodal freight or transshipment facilities, and major transportation routes. Traded-sector has the meaning provided in ORS 285B.280 (OAR 660-009-0005)(8).

(7) “Serviceable” means the city has determined that public facilities and transportation facilities, as defined by OAR 660, divisions 011 and 012, currently have adequate capacity for development planned in the service area where the site is located or can be upgraded to have adequate capacity within the 20-year planning period (OAR 660-009-0005)(9).

(8) “Short-term Supply of Land” means suitable land that is ready for construction within one year of an application for a building permit or request for service extension. Engineering feasibility is sufficient to qualify land for the short-term supply of land. Funding availability is not required. “Competitive Short-term Supply” means the short-term supply of land provides a range of site sizes and locations to accommodate the market needs of a variety of industrial and other employment uses (OAR 660-009-0005)(10).

(9) “Site Characteristics” means the attributes of a site necessary for a particular industrial or other employment use to operate. Site characteristics include, but are not limited to, a minimum acreage or site configuration including shape and topography, visibility, specific types or levels of public facilities, services or energy infrastructure, or proximity to a particular transportation or freight facility such as rail, marine ports and airports, multimodal freight or transshipment facilities, and major transportation routes (OAR 660-009-0005)(11).

(10) “Suitable” means serviceable land designated for industrial or other employment use that provides, or can be expected to provide the appropriate site characteristics for the proposed use (OAR 660-009-0005)(12).

(11) “Total Land Supply” means the supply of land estimated to be adequate to accommodate industrial and other employment uses for a 20-year planning period. Total land supply includes the short-term supply of land as well as the remaining supply of lands considered suitable and serviceable for the industrial or other employment uses identified in a comprehensive plan. Total land supply includes both vacant and developed land (OAR 660-009-0005)(14).

(12) “Vacant Land, Employment” means an employment designated lot or parcel not currently containing permanent buildings or improvements. For purposes of determination of the presence of permanent buildings/improvements all residential lots or parcels with an improvement value of zero (0), as determined by the Jackson County Assessor, are considered vacant.

(13) Net Buildable Acre, Employment: Consists of 43,560 square feet of employment designated buildable land, after excluding present and future rights-of-way for streets and roads (OAR 660-024-0010(6)).

2019 – 2039 Employment BLI

APPENDIX “B” - Methodology for Calculation of Employment Buildable Land

The methodology used to inventory and calculate buildable lands is based on the definitions defined in Appendix A. The base data source for identification of buildable lands is the Jackson County Assessor’s Records dated April 2018, which has been modified to include such additional information as Comprehensive Plan designations, zoning, development status, etc. The modified database is referred to as the Buildable Lands Inventory (BLI2019.xls).

Step 1. Urban Area, Gross Acres – Using the City’s GIS the total geographic limits of the City’s urban area are mapped and the gross acres within the limits of the shape file calculated by area within the City Limits and UGB.

Step 2. Net Urban Area by Land Use and Zoning – Using BLI2018 sum by land use and zoning all tax lots within the City’s urban area (City Limits and UGB). Tax lots identified for street, road, or access right-of-way (public or private) purposes are not included.

Step 3. Right-of-Way – Deduct the totals (City Limits and UGB) in Step 2 total from Step 1 total, the balance representing acreage used for right-of-way for the City Limits and UGB.

The results of Steps 1 – 3 are presented in Tables 1 and 2 of the 2019 Employment BLI.

Step 4. Net Buildable Acres, Employment. The methodology for calculating Buildable Employment Land involves the following steps:

Step 4a. Employment Vacant Acres. The BLI identifies all tax lots by their land use designation, zoning, development status, improvement and land value, and development constraints. When the improvement value of a property is zero the property is defined as Employment Vacant Land. The BLI sums the acreage for all Employment Vacant Land by land use and zoning for the City Limits and the UGB.

Step 4b. Constrained Acres. The BLI includes information on the amount of constrained acreage for all lots or parcels. The BLI sums the constrained acreage for all employment designated properties, by land use and zoning and subtracts from Total Vacant Acres (Step 4a).

Step 4c. Gross Buildable Vacant Employment Acres. Using the sum of the totals generated from Steps 4a and 4b the BLI calculates the Gross Buildable Vacant Employment land by land use and zoning for the City Limits and the UGB.

Step 4d. Public Facility Acres. The Gross Buildable Vacant Acreage figure (Step 4c) is reduced by 25% to account for public right-of-way to yield Net Buildable Vacant Acreage.

Step 4e. Employment Redevelopment Acres. The BLI identifies all employment designated tax lots for their redevelopment potential. Employment designated properties in excess of with a Land (L) to Improvement (I) ratio in less than 1 are defined and have

2019 – 2039 Employment BLI

a single-family detached dwelling on-site are considered to be redevelopable during the 20-year planning period.

Step 4f. Total Net Buildable Employment Acres. The Employment Redevelopment Acres (Step 4e) are added to the Net Buildable Vacant Acres (Step 4e) to yield Total Net Buildable Acres for the City's employment lands.

| Sector | New Buildable Acres Needed by 2039 | Gross Employment | |
|----------------------------|--|-----------------------------|---|
| | | Acres Needed, 2019- 2039 | Short-Term Gross Acres Needed, 2019-2024 |
| Industrial | - | - | - |
| Commercial/Service | 21 | 27 | 7 |
| Institutional/Government | 18 | 23 | 6 |
| Other/Uncovered Employment | 34 | 43 | 11 |
| Total Employment | 74 | 93 | 23 |

The goals and policies reflect the City's need to maintain a proactive and collaborative approach to economic development, providing an adequate and suitable land supply, and encouraging small businesses and business innovation. Additionally the Economic Element addresses an increased emphasis on providing land supply and opportunity for pedestrian oriented neighborhood commercial centers consistent with policies in the Regional Plan and Land Use Elements.

At the June 27, 2019 City Council meeting staff will present an overview of the Economic Element methodology and key findings (Attachment "A").

FINANCIAL ANALYSIS:

The Economic Element evaluates the City's opportunities for economic growth over the next 20-years and does not generate additional cost to the City beyond the in-kind staff expenses, postage and legal notification costs included budgeted for Community Development.

LEGAL ANALYSIS:

Text amendments to the Comprehensive Plan are considered "Major Amendments" per CPMC 17.96.300 and are subject to Type IV Legislative application procedures per CPMC 17.05.500. Per these regulations, two duly noticed public hearings are required including one conducted by the Planning Commission (6/4/2019) and one by the City Council (6/27/2019). The public hearing and first reading are consistent with the procedural requirements of the Central Point Municipal Code.

COUNCIL GOALS/STRATEGIC PLAN ANALYSIS:

The City Council goal to provide managed growth and infrastructure is predicated on the ability of the City to forecast growth and the corresponding land and service needs over the long term relative to the ability of the City to accommodate growth within the current UGB. The 2019-3029 Economic Element update aligns with Council's goal by evaluating changes to population, buildable lands on employment needs over the next 20-years. This is a prerequisite to, "Continually ensuring that planning and zoning review and regulations are consistent with comprehensive plans and vision." Additionally, the Economic Element update is necessary to evaluate the need for adding employment land to the UGB in the CP-3 Urban Reserve Area.

STAFF RECOMMENDATION:

After receiving the staff report, open the public hearing to receive public input regarding the 2019-2039 Economic Element. Close the public hearing and 1) forward to a second reading; 2) forward to a second reading with changes; or 3) deny the 2019-2039 Economic Element.

RECOMMENDED MOTION:

Forward the Ordinance Approving the Central Point Comprehensive Plan Economic Element (2019-2039) to a Second Reading at the July 11, 2019 City Council Meeting.

ATTACHMENTS:

1. Ordinance Approving the Economic Element (2019-2039)
2. Economic Element (6/27/2019)

ORDINANCE NO. _____

AN ORDINANCE UPDATING AND ADOPTING THE CENTRAL POINT COMPREHENSIVE PLAN ECONOMIC ELEMENT

Recitals:

- A. The City of Central Point (City) is authorized under Oregon Revised Statute (ORS) Chapter 197 to prepare, adopt and revise comprehensive plans and implementing ordinances consistent with the Statewide Land Use Planning Goals.
- B. The City has coordinated its planning efforts with the State in accordance with ORS 197.040(2)(e) and OAR 660-030-0060 to assure compliance with goals and compatibility with City and County Comprehensive Plans.
- C. Pursuant to authority granted by the City Charter and the ORS, the City has determined to update its Economic Element which was originally adopted in 1980 and revised in 1983.
- D. Pursuant to the requirements set forth in CPMC Chapter 17.10.100 Amendments – Purpose and Chapter 17.96.010, Procedure, the City has initiated the amendments and conducted the following duly advertised public hearings to consider the proposed amendments:
 - a) Planning Commission hearing on June 27, 2019; and,
 - b) City Council hearing on June 27, 2019.

THE PEOPLE OF THE CITY OF CENTRAL POINT DO ORDAIN AS FOLLOWS:

Section 1. Based upon all the information received, the City Council adopts the Staff Reports and evidence which are incorporated herein by reference; determines that changes community conditions, needs and desires justify the amendments and hereby adopts the changes entirely.

Section 2. The City Comprehensive Plan Economic Element is hereby updated and adopted as set forth in Exhibit A –Comprehensive Plan Economic Element, 2019 which is attached hereto and by this reference incorporated herein.

Section 5. The City Manager is directed to conduct post acknowledgement procedures defined in ORS 197.610 et seq. upon adoption of the Economic Element.

Passed by the Council and signed by me in authentication of its passage this 11th day of July, 2019.

Mayor Hank Williams

ATTEST:

City Recorder

Attachment: Ordinance Approving the Economic Element (2019-2039) (1163 : Economic Element)

ECONOMIC ELEMENT 2019-2039

City of Central Point Comprehensive Plan

Prepared by
Huycke O'Connor Jarvis, LLP
823 Alder Creek Drive
Medford, OR 97504

June 2019

PUBLIC HEARING DRAFT

Attachment: Economic Element (6/27/2019) (1163 : Economic Element)

Preface

Legal Requirements: Oregon law requires local municipalities to adopt an Economic Element as a part of their Comprehensive Plans. OAR 660-009-0015. These Economic Elements help to implement Oregon Statewide Planning Goal #9, which is “to provide adequate opportunities throughout the state for a variety of economic activities vital to the health, welfare, and prosperity of Oregon’s citizens.” That is, Goal #9 encourages local governments, like Central Point, to achieve their economic development planning goals so as to benefit the state’s residents.

Framework: Oregon Administrative Rules, Chapter 660, Division 9 calls for a four-step approach to economic development planning:

1. Review national, state, regional, county, and local economic trends
2. Identify the types and number of sites needed to accommodate growth
3. Inventory the industrial lands, employment lands, and vacant lands
4. Assess the community’s potential for economic development

This Economic Element follows these steps: Section 1 reviews Central Point’s economic history, Section 2 analyzes national economic trends, Section 3 reviews economic data concerning the State of Oregon, Section 4 reviews both Southern Oregon and Central Point’s economy, Section 5 contains a Population and Employment Forecast, Section 6 analyzes land demand for Central Point in both the short-term (5 years) and long-term (20 years), and Section 7 outlines the City’s economic goals and policies that will guide the City of Central Point through the twenty-year planning period (2019-2039).

This document will help guide the City of Central Point’s future growth and development, correct problems, maximize potentials, and act as a guide for decision-making. For a more complete analysis of Central Point’s planning needs, *see* the Comprehensive Plan (updated 1983) and the corresponding *Population, Housing, and Land Use Elements*, as well as the Central Point *Employment Buildable Lands Inventory* (2019-2039).¹

This document should be read along with the Central Point *Buildable Lands Inventory* (2019) and any subsequent inventory updates.

¹ *See generally* City of Central Point, *The Comprehensive Plan* (updated 1983).

Table of Contents

- Preface..... 2
- Table of Contents..... 3
- List of Figures:..... 5
- Introduction..... 6
- Summary..... 7
- Section 1: Central Point’s Economic History..... 8
- Section 2: National Economic Trends 9
 - Measuring the National Economy 9
 - i. Gross Domestic Product 9
 - ii. Employment..... 12
 - iii. Inflation..... 14
 - National Economic Crosscurrents: 16
 - i. Trade Wars..... 16
 - ii. Income Inequality 17
 - iii. Cost of Health Care..... 17
 - iv. Cost of Education..... 18
- Section 3: State Economic Trends 19
 - Neighboring States..... 19
 - Measuring the State Economy 20
 - i. Gross Domestic Product 20
 - ii. Employment..... 21
 - iii. Industry Strengths 23
 - State Economic Crosscurrents: 25
 - i. The National Economy 25
 - ii. Trade Wars..... 25
 - iii. Housing Affordability..... 26
 - iv. Wildfires and Smoke..... 26
- Section 4: Economic Trends in Southern Oregon..... 27
 - i. Gross Domestic Product 27
 - ii. Employment..... 29
 - iii. Housing..... 30
- Section 5: The City of Central Point’s Trends..... 31
 - Measuring the City’s Trends..... 31
 - i. Commuting Patterns..... 31
 - ii. Local Population Forecast..... 32
 - iii. Regional Employment Forecast..... 35
 - iv. Regional Competitiveness 40
 - v. Economic Development Context 42
 - vi. Competitive Position Summary 44
 - vii. Assessment of Central Point’s Economic Development Potential 44
 - viii. Central Point’s Projected Job Growth..... 46
- Section 6: Land Demand..... 48
 - Economic Growth Rate Forecast 48
 - i. Specialty Food Manufacturing..... 48

Attachment: Economic Element (6/27/2019) (1163 : Economic Element)

- ii. Trucking and Warehousing..... 48
- iii. Retail..... 49
- iv. Projected Growth Forecast by Industry 49
- i. Site Requirements Analysis 50
- ii. Target Industries’ Unique Site Requirements..... 51
- Long-Term Land Demand Estimate 52
- iii. Estimate of Needed Employment Lands..... 53
- Short-Term Land Demand Estimate 54
- Inventory of Employment Lands 54
- i. Redevelopment and Land Use Efficiency..... 55
- ii. Vacant Lands 55
- iii. Conclusion 56
- Section 7: Goals and Policies..... 58
- Policy 1: Participation..... 59
- Policy 2: Refine Policies..... 59
- Policy 3: Monitor Long-Term Consequences..... 59
- Policy 4: Small Businesses 60
- Policy 5: Business Innovation..... 60
- Policy 6: Tolo Area..... 60
- Policy 7: Monitor Regulations 60
- Policy 8: Adequate Short-Term Supply 60
- Policy 9: Prepare for Long-Term Needs..... 60

Attachment: Economic Element (6/27/2019) (1163 : Economic Element)

List of Figures:

| | |
|---|----|
| Figure 1: Percent Change in Quarterly GDP | 11 |
| Figure 2: National Unemployment Rate Since 1950 | 13 |
| Figure 3: National Unemployment Rates Since 2006..... | 13 |
| Figure 4: 1949-2018 Consumer Price Index for All Urban Consumers | 15 |
| Figure 5: 2005-2018 Consumer Price Index for All Urban Consumers | 15 |
| Figure 6: U.S. Health-Care Spending as a Share of GDP..... | 17 |
| Figure 7: Oregon GDP 1997-2017..... | 20 |
| Figure 8: Short-Term Economic Scenarios for Oregon | 21 |
| Figure 9: Oregon’s Unemployment Rate | 22 |
| Figure 10: Oregon Occupational Employment and Wage Estimates from May 2016 | 23 |
| Figure 11: Changes to Jackson County’s GDP | 28 |
| Figure 12: Changes to Josephine County’s GDP..... | 28 |
| Figure 13: Jackson County Unemployment Rate | 29 |
| Figure 14: Central Point Resident Commuting Patterns..... | 31 |
| Figure 15: Jackson County—Total Population by Five-year Intervals (1975-2017) | 33 |
| Figure 16: Population Growth Projections for City of Central Point and Jackson County | 34 |
| Figure 17: Central Point Population Pyramid..... | 34 |
| Figure 18: Rogue Valley Occupational Employment Change, 2017-2027 | 36 |
| Figure 19: Rogue Valley Industry Employment Change, 2017-2027 | 38 |
| Figure 20: Industry Employment Forecast, 2017-2027 | 39 |
| Figure 21: Employment Growth Forecast..... | 40 |
| Figure 22: Jackson County Shift-Share Analysis 2010-2017 | 40 |
| Figure 23: Central Point’s Qualitative Trends | 42 |
| Figure 24: Central Point's Economic Development Potential..... | 45 |
| Figure 25: Central Point’s population growth rate | 47 |
| Figure 26: Central Point's 20-year job forecast by industry | 47 |
| Figure 27: Central Point Projected Growth Rate by Industry | 50 |
| Figure 28: General Development Pattern Site Requirements | 51 |
| Figure 29: Projected Employment Net Buildable Land Needed 2019 to 2039 | 53 |
| Figure 30: Gross Acres Needed | 54 |



Introduction

Purpose: The purpose of this Economic Element is to determine the City of Central Point’s economic goals, policies, and land use needs. It identifies economic development opportunities and corresponding employment land needs for the next 20 years (2019-2039). It also provides a realistic analysis of current economic trends and potential disruptions. Through this, Central Point will be better able to reduce costs and delays, anticipate obstacles, and keep planning activities aligned with the City’s policies.

Past Elements: The City of Central Point first began developing its Comprehensive Plan in 1973.² In 1980, the Rogue Valley Council of Governments prepared the City of Central Point’s first Economic Element.³ That document was subsequently succeeded in 2013 by a version prepared by CSA Associates.⁴ This Economic Element of 2018 supersedes the previous versions and becomes part of Central Point’s Comprehensive Plan. It establishes the framework for future economic growth and development and gives a long-range evaluation of the City’s changing characteristics and needs.

Geographic Scope: This Economic Element is limited in scope to developments within the Central Point city limits and the Urban Growth Boundary. Central Point is located near the geographic center of Jackson County in southwestern Oregon, approximately midway between Portland and San Francisco.⁵ The City has the advantage of being located directly on Interstate 5 (I-5), Highway 99 (U.S. Route 99), the Central Oregon Pacific Railway, and adjacent to the Rogue Valley International Airport. Immediately to the south of Central Point is the City of Medford, which is the seat of Jackson County and the largest city in Southern Oregon. This provides Central Point residents with easy access to major shopping centers, employment, and governmental activities.

² *Id.* at Preface 1.

³ City of Central Point, *Economic Element 2013-2033* at 5 (2013).

⁴ *See id.*

⁵ City of Central Point, *The Comprehensive Plan*, Part IV, Plan Summary 3 (updated 1983).

Summary

This Economic Element includes an economic history of Central Point, it analyzes current national, state, and regional economic trends, includes an employment forecast, and an inventory of lands used for employment. The final section outlines the City's economic goals and policies that will guide the City through the twenty-year planning period (2019-2039).

The national economy is doing well, with GDP at a very healthy rate, unemployment down, and inflation moderate. However, leading economists are warning that the U.S. economy will slow and may even slide into a recession around the year 2020. Further, the economic health of the country is increasingly threatened by the possibility of trade wars, growing income inequality, and the costs of health care and education. As a result, the City of Central Point must be prepared for economic fluctuations in both the short- and long-term, which could seriously impact its land use planning forecasts.

The state economy is “hitting the sweet spot” and doing well compared to other states. GDP is rising, employment has recovered from the Great Recession, and it has growing industries. However, the Oregon Office of Economic Analysis projects that the state economy is at risk from the U.S. economy's volatility, retaliatory tariffs from Canada and China, a prolonged affordable housing crisis, as well as the impact of forest fires and smoke. While the economy may remain strong, the City should brace itself for a slowdown like the 1990s recession.

The Southern Oregon region is doing even better than the state economy. Although the region was hit hard by the Great Recession, and recovery has been difficult, the GDP is growing faster than the national rate and USA Today has ranked both Jackson and Josephine counties as the 28th and 18th best local economies in the nation respectively. Nevertheless, the area still has high unemployment rates and is suffering from a lack of affordable housing for middle class workers.

Central Point has a high population growth rate and is expected to grow to approximately 26,000 people by 2039. This means that Central Point will surpass the City of Ashland's population and capture almost 7 percent of the new jobs in the region over the next 20 years. The gains will be concentrated in service, health care, construction, professional, and the business industries. Its target industries include specialty foods, trucking and warehousing, and retail. According to the population and job capture rate, Central Point will need approximately 13 acres of new employment lands in the next 5 years and anywhere from 65 to 73 new acres by 2039.

Ultimately, future economic conditions cannot be accurately predicted. However, strategically planning the City of Central Point's land base for the long-term has the potential to benefit economic development in the City and the surrounding area. This includes preparing to accommodate future needs and integrating the City's land use planning efforts within a broader economic development strategy.

Central Point's last Economic Element was created in 2013. Because it relied on data from the 2010 census, and because there will be little new data before the 2020 census, much of this Economic Element is similar or identical to that of the last element. Furthermore, many of the conclusions in that element remain valid and are adopted.

Section 1: Central Point's Economic History.

Central Point's economic history has centered on trade, resource-based industries such as forest products and agriculture, and minor retail for its residential areas.

Incorporated by the State Legislature in 1889, Central Point was so named because of its location at the center of the inhabited parts of the Rogue Valley.⁶ Before then, Jacksonville had served as the region's economic center. However, when the railroad was built, Jacksonville was bypassed, and the tracks were built through what is now Central Point.

Central Point's railroad station was the closest point to reach Crater Lake from the South. All the county roads leading from Ashland, Jacksonville, and Medford passed through Central Point, making it a prime area for shipping and trading.⁷

Central Point is located near some of Jackson County's most fertile soils and was well located to serve the surrounding farmers. Indeed, this remained the foundation of the City's economy well into the 1960s. Central Point's location allowed it to act as a trading location for the farming community, a location for schools, and as a well-placed area for shops and services. The City housed the Grange Co-op's grain elevator and various farm repair shops and equipment retail.

Between the 1960s and 1970s, the City of Central Point rapidly expanded its residential development. Because there was no corresponding development of commercial and industrial industries, Central Point became a residential community largely inhabited by people who commuted to nearby cities for work. During this period the forest products industry grew, and residents of Central Point were able to find employment at the mills in Medford and White City.

In 1980, the City of Central Point adopted its first Economic Element that has herewith been replaced by this Economic Element. The U.S. economy has undergone several economic cycles since then. The 1980 Economic Element sought to diversify the City's economy and reduce the degree of imbalance between employment and housing within the City. Central Point has been successful to some extent over the last thirty years in its efforts to diversify its economy. The City has experienced retail and industrial growth in and around Exit 33 on Interstate 5. Providence Hospital recently added a medical facility on Highway 99 south of Pine Street. A small specialty foods cluster has developed along Highway 99 north of Pine Street that includes Rogue Creamery, Lillie Belle Farms chocolates and a wine tasting room. The Rogue Valley Council of Governments has its main office building near downtown Central Point. A new Costco Wholesale store opened off of Table Rock Road in 2017. Further, newer retail exists near freeway interchanges and along Pine Street and Highway 99. These employers and others have served (and an overarching objective of this Economic Element is) to continue to add more balance and diversity to the City's employment base.

⁶ *Democratic Times*, Jacksonville, page 1 (July 18, 1889).

⁷ *Id.*

Section 2: National Economic Trends

Purpose It is important to review current trends in the U.S. economy. The national economy provides the necessary context for the adoption of updated economic development policies and strategies in the City’s Comprehensive Plan. By engaging with governmental projections and economic forecasts, the City will be better able to position itself for long-term success. This review of national trends will help inform the Economic element by providing a foundation to describe the City’s economic advantages and disadvantages.

National Economic Trends The U.S. economy is booming. However, “potential danger lurks around the corner.”⁸ Over the last decade, the national economy has largely recovered from the Great Recession: unemployment is the lowest it has been in half a century, inflation is moderate, people appear confident in the economy, and the International Monetary Fund has projected a short-term growth of just under 3 percent.⁹

However, the Oregon Office of Economic Analysis warns that there are signs of a potential economic slowdown around 2020. Economic crosscurrents threaten economic stability, including the potential for global trade wars, increasing costs of health care, and the increasing burdens of higher education on younger generations. This indicates the likelihood of strong short-term growth for the United States but relative weakness in the medium and long term.¹⁰ While there will likely be a downturn in the economy, it will probably be less severe than the Great Recession.¹¹ Because there is no obvious asset or investment bubble today (unlike the subprime mortgages of 2008), if a recession occurs it will probably be similar to the recession of 1990.¹²

Measuring the National Economy

There are many ways to analyze the national economy, such as the GDP, unemployment rate, and inflation rates. Each of these helps to describe how well the economy is doing and may indicate how healthy the economy will be in the future.

i. Gross Domestic Product

What is Gross Domestic Product? Gross Domestic Product (“GDP”) is a measurement of how many goods and services the United States produces.¹³ Because it measures production, it is one of the primary indicators used by economists to determine the health of the economy.¹⁴ The ideal

⁸ Oregon Economic and Revenue Forecast, XXXVIII, No. 3 at 2 (Sept. 2018).

⁹ Everett Rosenfeld, *Mohamed El-Erian: The US economy looks ‘good’ for the ‘next couple of years at least’*, CNBC (Oct. 9, 2018), available at: www.cnbc.com/2018/10/09/mohamed-el-erian-us-economy-headed-for-solid-growth-for-couple-years.html.

¹⁰ *Id.* at 6.

¹¹ Josh Lehner, *Hammer Don’t Hurt ‘Em*, Oregon Office of Economic Analysis (Oct. 26, 2018), available at: oregoneconomicanalysis.com/2018/10/26/hammer-dont-hurt-em/.

¹² *Id.*

¹³ Harriet Torry, *U.S. Economy Grew at 3.5% Rate in Third Quarter*, Wall Street Journal U.S. Edition (Oct. 26, 2018), available at: www.wsj.com/articles/u-s-economy-grew-at-3-5-rate-in-third-quarter-1540557378.

¹⁴ Leslie Kramer, *What is GDP and why is it so important to economists and investors?* Investopedia (Feb. 5, 2018), available at: www.investopedia.com/ask/answers/what-is-gdp-why-its-important-to-economists-investors/.

GDP growth rate is between 2-3 percent.¹⁵ If GDP grows too slowly it could indicate some economic unhealthiness; if it grows too fast it could mean that there is an asset bubble and that the economy is overheating.

Past Trends Since Central Point published its first economic element in 1980, the national GDP has had its ups and downs. The Recession of the early 1980s was followed by an economic boom that lasted until 1990. The short Recession of 1990 was followed by a decade of economic prosperity. Although there was a modest downturn in 2000-2001, that was replaced with continuing economic expansion through 2006. Then came the Great Recession, the worst period since World War II from a GDP perspective. In five out of six quarters from the end of 2007 to the beginning of 2009 the GDP actually went negative. After a decade of recovery, the Bureau of Labor Statistics anticipates that the economy will fully recover by 2020.¹⁶

Recent Growth Currently, the U.S. GDP is increasing at a good rate. See **Figure 1**. Although there has not been explosive growth,¹⁷ the Oregon Office of Economic Analysis has characterized the US economy as “entering into its boom phase of the business cycle.”¹⁸

The last two quarters mark the strongest back-to-back quarters of U.S. economic growth since 2014.¹⁹ According to the Department of Commerce, the national GDP grew at a rate of 3.5 percent in the third quarter of 2018.²⁰ While this was stronger than expected, this was down from 4.2 percent expansion in the previous quarter.²¹ Economists have explained that this was due to strong consumer spending,²² a drop in unemployment,²³ and the results of the recent tax cuts, including business investment, the restocking of inventories,²⁴ and excessive borrowing by the Federal Government.²⁵

¹⁵ Kimberly Amadeo, *What is the Ideal GDP Growth Rate: How Fast Should the Economy Grow?* The Balance (Oct. 5, 2018), available at: www.thebalance.com/what-is-the-ideal-gdp-growth-rate-3306017.

¹⁶ *Id.*

¹⁷ Matt Egan, *The US Economy Just Hit a Milestone*, CNN Business (May 1, 2018) available at: money.cnn.com/2018/05/01/news/economy/us-economy-great-recession-recovery/index.html.

¹⁸ Oregon Economic and Revenue Forecast, XXXVIII, No. 3 at 2 (Sept. 2018).

¹⁹ William Sprouse, *U.S. GDP Continues Hot Streak*, CFO Magazine (October 26, 2018), available at: ww2.cfo.com/the-economy/2018/10/u-s-gdp-continues-hot-streak/.

²⁰ U.S. Department of Commerce, Bureau of Economic Analysis, *Gross Domestic Product, 3rd quarter 2018 (advance estimate)* (Oct. 26, 2018).

²¹ Fred Imbert, *The US economy grew at a 3.5% pace in the third quarter, faster than expected*, CNBC (Oct. 26, 2018), available at: www.cnbc.com/2018/10/26/first-read-on-us-q3-2018-gross-domestic-product.html.

²² *Id.*

²³ Matt Egan, *The US Economy Just Hit a Milestone*.

²⁴ Sarah Foster, *What Economists Are Saying Ahead of Third-Quarter U.S. GDP Data*, Bloomberg (Oct. 25, 2018), available at: www.bloomberg.com/news/articles/2018-10-26/what-economists-are-saying-ahead-of-third-quarter-u-s-gdp-data.

²⁵ Matt Egan, *The US Economy Just Hit a Milestone*.

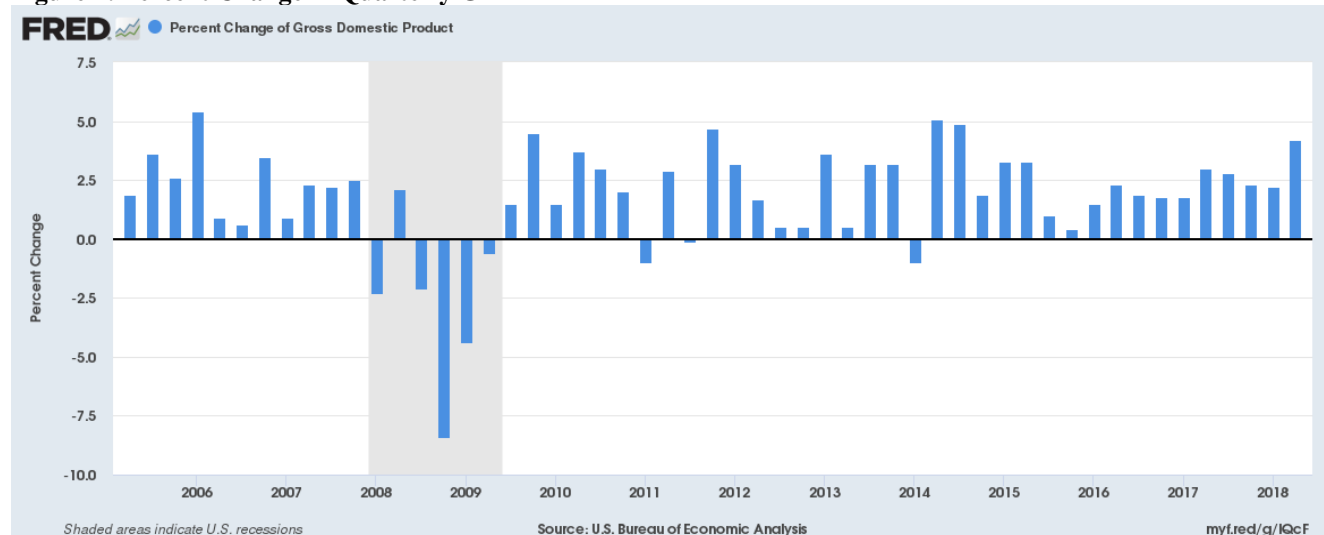
Figure 1: Percent Change in Quarterly GDP

Short-Term Projections The U.S. GDP is currently on a “hot streak”²⁶ and will probably maintain 2.5-3 percent growth through 2019. However, it is difficult to predict future growth beyond that. In fact, forecasts by national economists for short-term growth are conflicted. While some predict multiple years of 3 percent growth,²⁷ the International Monetary Fund has projected a short-term growth of under 3 percent for 2018 and 2.5 percent for 2019.²⁸ The Federal Reserve has a similar opinion, projecting that the GDP rate will decrease to 2.5% in 2019, 2% in 2020, and 1.8% in 2021.²⁹ This, coupled with the threat of a major trade war with China, have led to fears of an economic slowdown sometime around 2020. In fact, Moody's Analytics chief economist Mark Zandi has said, “By mid-2020, we will be most vulnerable to the next recession.”³⁰

Long-Term Projections It is even more difficult to project how the national GDP will fare over the next two decades. Josh Lehner of the Oregon Office of Economic Analysis has said, “trying to forecast a period of prolonged weakness, or even a possible recession two years in advance is a fool’s errand . . . There’s just too much time, too many potential variables . . . to alter the course that far in the future.”³¹

Here, there are too many variables that can change. However, some things will occur with near-certainty. First, over the next two decades the economy will evolve. Some industries will diminish, some will expand, while still others will be created. Second, there will be some good years and some not-so good years. That is, things will not always be as good as they are now. Third, on average, there will probably be more years of healthy GDP growth than not.

²⁶ William Sprouse, *U.S. GDP Continues Hot Streak*.

²⁷ Everett Rosenfeld, *Mohamed El-Erian: The US economy looks ‘good’ for the ‘next couple of years at least.’*

²⁸ *Id.*

²⁹ Harriet Torry, *U.S. Economy Grew at 3.5% Rate in Third Quarter*, Wall Street Journal U.S. Edition (Oct. 26, 2018), available at: www.wsj.com/articles/u-s-economy-grew-at-3-5-rate-in-third-quarter-1540557378.

³⁰ Matt Egan, *The US Economy Just Hit a Milestone*.

³¹ Josh Lehner, *Hammer Don’t Hurt ‘Em*.

Conclusion Central Point must accept the reality of long-term GDP fluctuations when engaging in planning and decision-making. City leaders should not adopt the view that because things are good now that they will always be good. Instead, Central Point should have long-term plans that accept the fundamentals of the free market.

ii. Employment

What is Unemployment? Unemployment measures how many people in the country do not have jobs. Unemployment occurs when a person who is actively searching for a job is unable to find work.³² Like GDP, it is one of the main indicators of an economy's health. Of particular importance to economists is the "unemployment rate," which is calculated by taking the number of unemployed people and dividing by the number of people employed.³³ Unlike GDP, the unemployment rate usually rises or falls after changing economic conditions, rather than anticipating an economic event.³⁴ Even a healthy economy will have a certain number of people unemployed: some will be between jobs and others will have been displaced by an evolving economy.

Past Trends The United States has never had zero percent unemployment. The lowest rate ever recorded was 2.5 percent in mid-1953. It occurred because "the economy overheated during the Korean War. When this bubble burst, it kicked off the recession of 1953."³⁵ Since Central Point published its first Economic Element, the U.S. unemployment rate has fluctuated in line with the economic booms and busts. The highest rates were 10.8 percent in 1982 and 10 percent at the height of the Great Recession in December 2009. In turn, the lowest rates were 3.8 percent in April 2000, and 4.4 percent in 2006 and 2007.

Recent Trends Currently, the U.S. unemployment rate has fallen to 3.7 percent, the lowest in nearly half a century.³⁶ **Figure 2** depicts the rapid increase in unemployment during the Great Recession and the slow recovery over the last decade. Unemployment has been declining and has finally fallen below pre-Recession levels. The Bureau of Labor Statistics assumes that the economy will fully recover from the Great Recession by 2020 and that the labor force will return to a full unemployment rate of 4 to 5 percent.³⁷

³² *What is Unemployment*, Investopedia, available at: www.investopedia.com/terms/u/unemployment.asp#ixzz5VjPvdupQ.

³³ *Id.*

³⁴ *What is Unemployment Rate*, Investopedia, available at: www.investopedia.com/terms/u/unemploymentrate.asp.

³⁵ Kimberly Amadeo, *Natural Rate of Unemployment, Its Components, and Recent Trends: Why Zero Unemployment Isn't as Good as It Sounds*, The Balance (Sept. 26, 2018).

³⁶ William Sprouse, *U.S. GDP Continues Hot Streak*.

³⁷ Kimberly Amadeo, *What is the Ideal GDP Growth Rate: How Fast Should the Economy Grow?* The Balance (Oct. 5, 2018), available at: www.thebalance.com/what-is-the-ideal-gdp-growth-rate-3306017.

Figure 2: National Unemployment Rate Since 1950



Figure 3 depicts the strong relationship between unemployment and educational attainment. Those without a high school diploma have experienced unemployment rates that are almost double that of individuals with a college education. However, the rate of unemployment has been declining at a much faster pace over the last several years for those without a high school diploma than those with a college education. Overall, unemployment levels are good when measured on a national scale.

Figure 3: National Unemployment Rates Since 2006

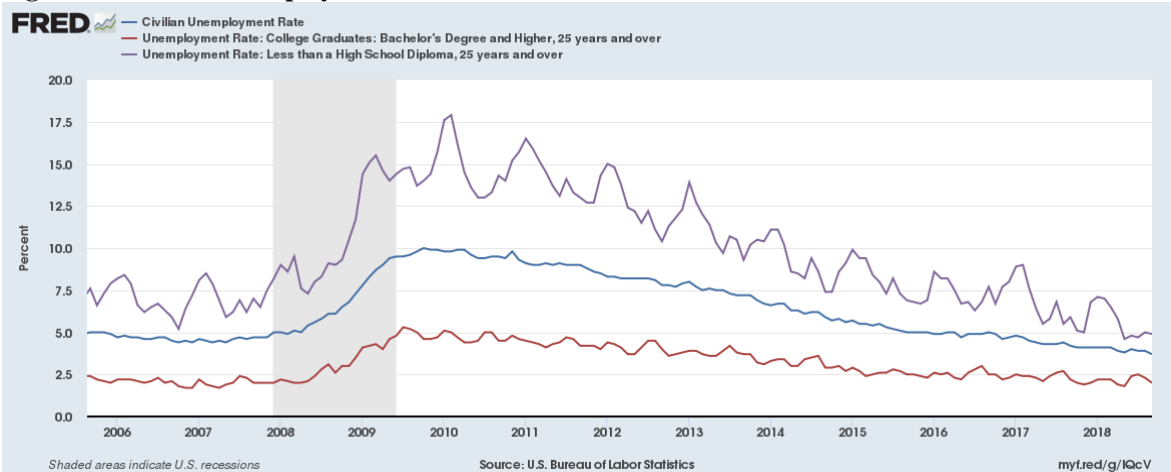

Short-Term Projections The current unemployment rate is unsustainable.³⁸ Both Moody’s Analytics and Goldman Sachs’s chief economists have forecasted that unemployment will continue to decline to 3 percent by early 2020.³⁹ However, there are conflicting forecasts after that. Either the anticipated 2020 slowdown could prevent the economy from overheating and

³⁸ Rebecca Rainey, *Happy Jobs Day!* Politico (Nov. 2, 2018), available at: www.politico.com/newsletters/morning-shift/2018/11/02/happy-jobs-day-399113.

³⁹ Brian Cheung, *Goldman Sachs warns the economy may be growing too quickly*, Yahoo Finance (Nov. 5, 2018), available at: sports.yahoo.com/goldman-says-fed-needs-avoid-dangerous-overheating-154158689.html. Also see Martin Crutsinger, *Fed likely to keep rates on hold and sketch a bright outlook*, AP (Nov. 5, 2018), available at: www.wacotrib.com/news/ap_nation/fed-likely-to-keep-rates-on-hold-and-sketch-a/article_eb9369f3-bf36-5557-977d-51354f1832a9.html.

temporarily stabilize the unemployment rate or the economy will slow too much, potentially destabilizing the employment rate, causing it to increase.⁴⁰ The Federal Reserve estimates that the normal unemployment rate (absent shocks to the economy) will rise back up to between 4-5 percent over the next five to six years.⁴¹ While it is unclear whether unemployment will hold steady for a while longer or if it will begin rising again as soon as 2020, it is highly probable that unemployment will be going back up.

Long-Term Projections Like forecasting GDP rates decades in advance, it is also difficult to project unemployment rates for the next two decades. However, it should be noted that the average unemployment rate for the U.S. between 1948 and 2018 was 5.77 percent, with a high of 10.8 percent and a record low of 2.5 percent. As a result, the average unemployment rate will probably stay in these bounds, close to the average.⁴²

Conclusion The unemployment rate is currently very low and will be going back up. A possible slowdown or recession around 2020 could either stabilize the rate or cause it to rise sharply. Ultimately, unemployment will probably stay around 3 percent for the next couple years and average 5 percent over the next two decades.

iii. Inflation

What is inflation? Inflation is the measure of how much the price of goods and services increases over time.⁴³ It means that things cost more and more instead of staying the same price. For example, if a gallon of milk has an inflation rate of 2 percent per year, then the price of milk will be 2 percent higher next year. Importantly, inflation is not primarily caused by the Federal Government printing too much money. Instead, inflation usually rises because buyers want products so much that they are willing to pay higher prices.

If workers' wages do not keep pace with inflation, people have less buying power. The opposite of inflation is deflation, which is when things cost less than they did before. It is important to measure inflation because it shows if on average people are prospering or suffering under the current economy.

Measuring Inflation There are different ways to measure inflation, but the U.S. Bureau of Labor Statistics uses the Consumer Price Index.⁴⁴ In the United States, the Federal Reserve aims for a target annual inflation rate of 2 percent.⁴⁵

Past trends **Figure 4** shows how inflation has occurred over the last seven decades. When Central Point first began developing its Comprehensive Plan, the United States was undergoing a

⁴⁰ *Id.*

⁴¹ Board of Governors of the Federal Reserve System, *What is the lowest level of unemployment that the U.S. economy can sustain?* FAQs (Sept. 26, 2018), available at: www.federalreserve.gov/faqs/economy_14424.htm.

⁴² Trading Economics, *United States Unemployment Rate*, (Oct. 2018), available at: tradingeconomics.com/united-states/unemployment-rate.

⁴³ Kimberly Amadeo, *Why Inflation Is as "Violent as a Mugger"* The Balance (Oct. 30, 2018), available at www.thebalance.com/what-is-inflation-how-it-s-measured-and-managed-3306170.

⁴⁴ *Id.*

⁴⁵ *Id.*

period of massive inflation. Inflation was over 7 percent in the 1970s and almost 6 percent in the 1980s. Since then, inflation has dropped to the 3 percent range in the 1990s and under 2 percent in the pre-Great Recession years. In 2009, inflation averaged -0.34 percent. However, inflation has been steadily climbing back up and, in the twelve months leading up to September 2018, the Consumer Price Index increased 2.3 percent.

Figure 4: 1949-2018 Consumer Price Index for All Urban Consumers

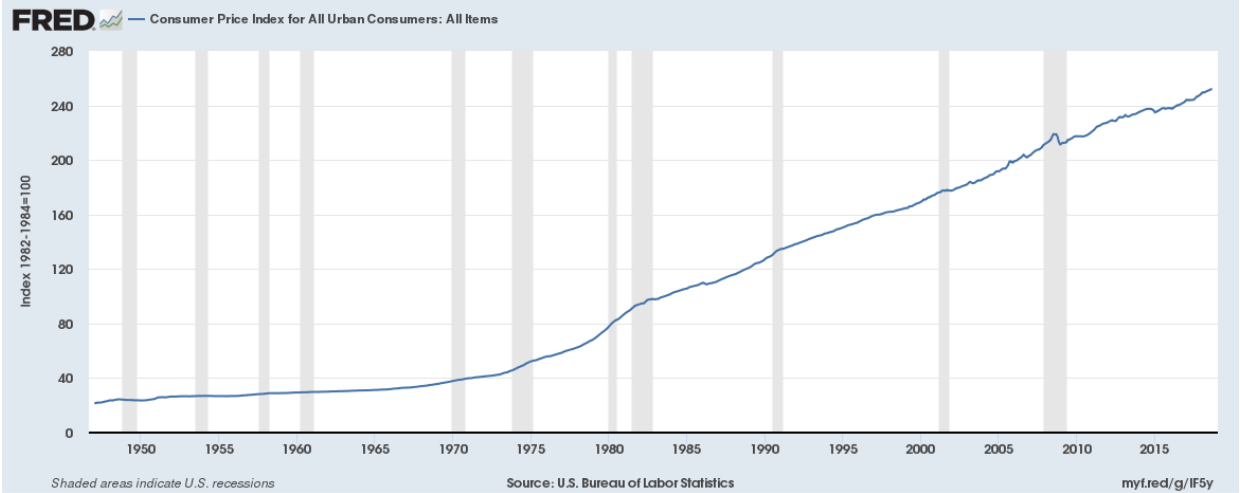

Short-Term Projections At the moment, inflation is relatively benign.⁴⁶ The price of food goods is remaining steady while the cost of vehicles has fallen sharply.⁴⁷ Increases in the Consumer Price Index have been tied to increasing rental prices and the cost of home ownership.⁴⁸ However, the Federal Reserve projects greater than 2 percent inflation over the next couple of years. See Figure 5, which shows the recent history of the Consumer Price Index.

Figure 5: 2005-2018 Consumer Price Index for All Urban Consumers

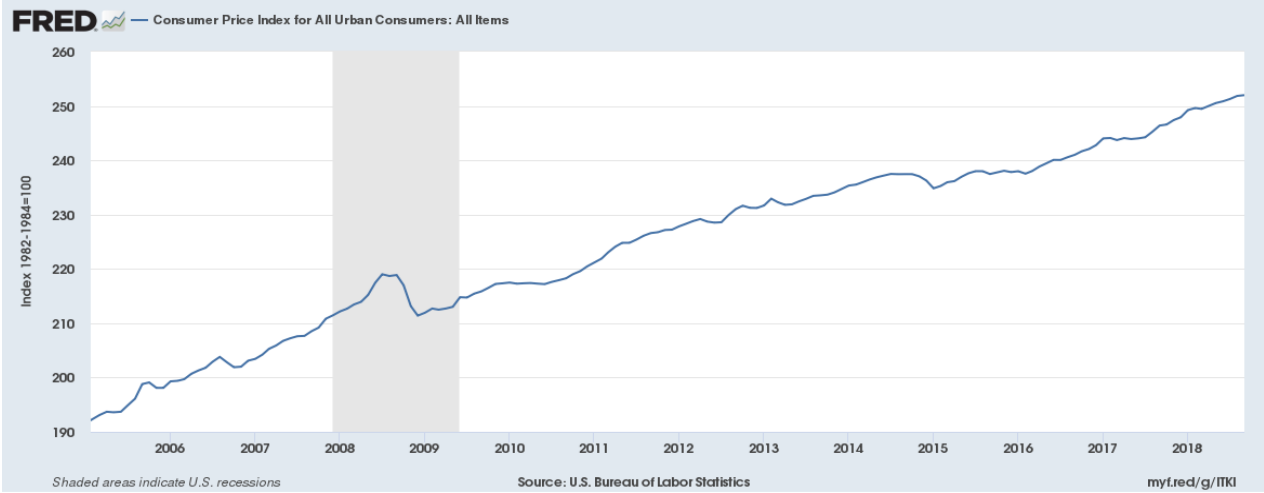

⁴⁶ Jeffrey Bartash, *Inflation rises slowly in September in latest sign of easing price pressures, CPI shows*, Market Watch (Oct. 11, 2018), available at: www.marketwatch.com/story/housing-costs-nudge-inflation-higher-in-september-cpi-shows-2018-10-11.

⁴⁷ *Id.*

⁴⁸ *Id.*

Attachment: Economic Element (6/27/2019) (1163 : Economic Element)

Long-Term Projections Although the current inflation rate is 2.28 percent, this is well below the 3.76 average since the end of WWII.⁴⁹ As a result, in the long term, inflation will probably be moving back up to better approach the average rate.

Conclusion In the long run, inflation will probably be increasing to better align with the averages of the last century. Unless wages also increase to meet inflation, it will become harder for individuals to purchase things.

National Economic Crosscurrents:

Primary Risks to the U.S. Economy The national economy appears healthy: GDP has a good growth forecast, unemployment is the lowest it has been in half a century, inflation is moderate, and people appear confident in the economy. In addition to analyzing the traditional measurements of economic success, it is also important to consider strategic threats to the economy that have not yet sufficiently impacted the economic data.

There are several things that put the economy at risk in both the short and long-term: trade wars, increasing income inequality, and the costs of health care and education.

i. Trade Wars

First among the dangers to the national economy is the simmering trade war. Although there has been little impact so far, the possibility of escalation could severely harm the national economy. Already, the US soy industry could be on the verge of collapse, with sales down 94 percent to China because of the retaliatory tariffs.⁵⁰ Because soybeans are usually routed through the Pacific Northwest on their way to Asia, this could harm Oregon's economy.⁵¹

Many other industries are also threatened, with duties on steel and aluminum costing U.S. companies about half a billion dollars in September 2018 alone.⁵² An escalation in the trade wars (either by including more countries or a wider range of goods) would harm U.S. industries, transportation companies, and consumers across the board.⁵³ It would also lead to an increase in prices and inflation, requiring the Federal Reserve to increase interest rates.

⁴⁹ Jill Mislinski, *A Long-Term Look at Inflation*, Advisor Perspectives (Oct. 2018), available at: www.advisorperspectives.com/dshort/updates/2018/10/12/a-long-term-look-at-inflation.

⁵⁰ Binyamin Appelbaum, *Their Soybeans Piling Up, Farmers Hope Trade War Ends Before Beans Rot*, New York Times (Nov. 5, 2018), available at: www.nytimes.com/2018/11/05/business/soybeans-farmers-trade-war.html

⁵¹ Isis Almeida, *Trump's Tariff War Scrambles Agricultural Trade Routes*, Bloomberg Business (Nov. 1, 2018), available at: www.bloomberg.com/news/articles/2018-11-01/trump-s-tariff-war-scrambles-u-s-trade-routes-as-soy-piles-up

⁵² Stephanie Dhue and Yian Mui, *American businesses paid 50% more in tariffs in September due to Trump's trade war, industry coalition says*, CNBC (Nov. 5, 2018), available at: www.cnbc.com/2018/11/05/tariff-payments-up-50percent-in-september-on-trump-trade-war-industry-group.html.

⁵³ Oregon Economic and Revenue Forecast, XXXVIII, No. 3, at 6 (Sept 2018).

ii. Income Inequality

Income inequality is a system-level issue for the United States economy.⁵⁴ Over the last 20 years, the top 10 percent of income earners have received a nearly 200 percent increase in their overall median net worth, while the bottom 40 percent of earners have seen an actual decline in their net worth.⁵⁵ This economic upheaval will have a major impact on government spending; an aging population that has less of an ability to support itself will require more help from entitlement and social programs. In the long term, it has the potential to negatively impact institutional investors' portfolios; increase financial and social system-level instability; damage output and slow economic growth; increase the Federal Deficit; and contribute to the tendencies toward protectionism and tariffs.⁵⁶

iii. Cost of Health Care

The cost of health care for the American consumer is increasing. Since the City of Central Point first began developing its Comprehensive Plan, the U.S. has gone from spending 7.2 percent of its GDP on health care to almost 18 percent today.⁵⁷ See **Figure 6**. While total inflation is averaging around 2.3 percent, healthcare has increased 3.7 percent. What is more, the price of health care is rising faster than normal prices and companies are having to spend more on health insurance premiums.⁵⁸ As a result, employees are taking less money home with them.

Figure 6: U.S. Health-Care Spending as a Share of GDP

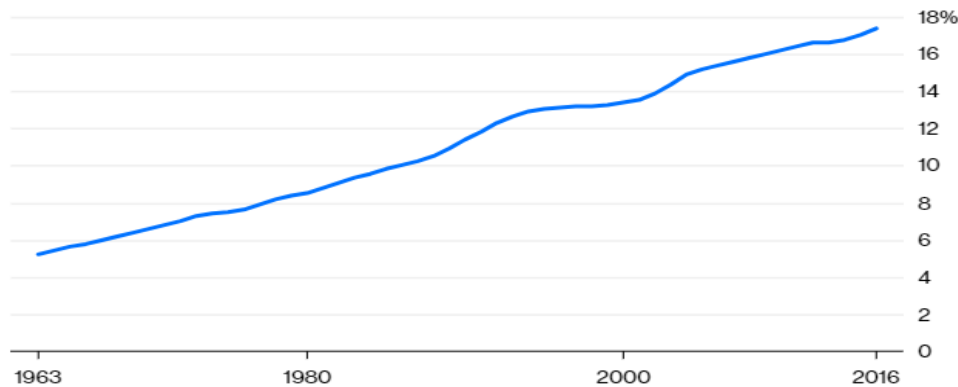

⁵⁴ Bob Eccles, *Investors Can And Should Address The Fundamental Causes Of Income Inequality*, Forbes (Oct. 30, 2018) available at: www.forbes.com/sites/bobeccles/2018/10/30/investors-can-and-should-address-the-fundamental-causes-of-income-inequality/#46f07c851ed5.

⁵⁵ Andrea Riquier, *Economic inequality could cause U.S. debt downgrade, Moody's says*, MarketWatch (Oct. 27, 2018), available at: www.marketwatch.com/story/economic-inequality-could-cause-us-debt-downgrade-moodys-says-2018-10-12.

⁵⁶ Steve Lydenberg, et al., *New Report: Why and How Investors Can Respond to Income Inequality*, The Investment Integration Project (2018) available at: www.tiiproject.com/wp-content/uploads/2018/10/Why-and-How-Investors-Can-Respond-to-Income-Inequality.pdf (PDF warning).

⁵⁷ Noah Smith, *Efforts to slow the rise in the country's insanely expensive system have gone nowhere*, Bloomberg (Oct. 29, 2018).

⁵⁸ *Id.*

iv. Cost of Education

The burden of student debt is likely to keep growing, which will dramatically inhibit the ability of younger generations to accumulate wealth.⁵⁹ Outstanding student loans are already approaching \$1.2 trillion.⁶⁰ While inflation is around 2.3 percent, and health care costs are rising at 3.7 percent, education expenses are rising at an incredible rate of 5.2 percent.⁶¹ In fact, if education inflation continues at this rate, the cost of tuition and fees for a four-year public university by 2028 will be between \$65,590 for in-state public schools and \$224,124 for private colleges.⁶²

Many parents are burdened with saving large amounts of money to pay for their children's college education. Further, many young adults are already burdened with enormous student loan debts. Because parents and/or college graduates will need to spend enormous sums on tuition, and wages are not rising to meet this increase, people will either be prevented from getting a higher education or will be stuck paying off loans for a much longer period. In either case, that is bad news for the economy.

⁵⁹ Andrea Riquier, *Economic inequality could cause U.S. debt downgrade, Moody's says*, MarketWatch (Oct. 27, 2018), available at: www.marketwatch.com/story/economic-inequality-could-cause-us-debt-downgrade-moodys-says-2018-10-12.

⁶⁰ Mike Patton, *The Cost of College: Yesterday, Today, and Tomorrow*, Forbes (Nov. 19, 2018), available at: www.forbes.com/sites/mikepatton/2015/11/19/the-cost-of-college-yesterday-today-and-tomorrow/#556eff706060.

⁶¹ *Id.*

⁶² *Id.*

Section 3: State Economic Trends

Oregon's economy is "hitting the sweet spot" and doing better than most other states.⁶³ Wages and household incomes are rising, and workers are coming back into the labor market.⁶⁴ Further, because state revenues are higher than forecasted, Oregon taxpayers should expect to receive a bonus "kicker" on their income tax returns in 2019.⁶⁵

While the state economy is doing well, it is also acting more volatile than the national economy.⁶⁶ Josh Lehner, senior economist at the Oregon Office of Economic Analysis, is concerned that while the economy is still growing, the pace of that growth is slowing down. Further, "We expect that pattern to continue—that growth tomorrow will be slower than growth today."⁶⁷

Panelists at the 15th Annual Oregon Economic Forum indicated that economic trouble for the state is likely still a few years away.⁶⁸ Bruce McCain, chief investment strategist at Key Private Bank has interpreted the data as suggesting that the state economy is one or two years away from a recession.⁶⁹ However, both McCain and Oregon Economic Forum director Tim Duy noted that a future recession may not be as bad as the Great Recession.⁷⁰

Neighboring States

Oregon is geographically well situated because its neighboring states to the north and south have very strong economies.

Washington State's GDP has grown 3 percent over the last five years, the largest increase in the nation.⁷¹ It has the 14th largest GDP in the country at \$439.4 billion in 2017.⁷² However, it also ranked 47th in the US by unemployment rate, which was 4.7 percent in June 2018.⁷³

California has the largest economy in the United States.⁷⁴ If California was a country, it would

⁶³ Oregon Economic and Revenue Forecast, XXXVIII, No. 3, at 6 (Sept 2018).

⁶⁴ *Id.* at 1.

⁶⁵ Jade McDowell, *Oregon's economy is strong, but how long will it last?* Eastern Oregonian (Oct. 12, 2018), available at: www.eastoregonian.com/eo/local-news/20181012/oregons-economy-is-strong-but-how-long-will-it-last.

⁶⁶ *Id.*

⁶⁷ *Id.*

⁶⁸ Anthony Macuk, *Economists at Oregon forum: Don't expect an imminent recession*, The Columbian (Oct. 17, 2018), available at: www.columbian.com/news/2018/oct/17/economists-at-oregon-forum-dont-expect-an-imminent-recession/.

⁶⁹ *Id.*

⁷⁰ *Id.*

⁷¹ Oregon Small Business Association Foundation, *Oregon #12 in nation's Best State Economies*, Oregon Business Report (Oct. 15, 2018).

⁷² *Id.*

⁷³ *Id.*

⁷⁴ *Id.*

have the fifth largest economy in the world.⁷⁵ California’s GDP grew almost as much as Washington’s at 2.9 percent over the last five years.⁷⁶ Its GDP was eleven times that of Oregon’s, at \$2.4 trillion. While its unemployment rate is slightly above average at 4.2 percent, it has had a five year annual employment growth of 2.2 percent, which is the eighth best in the nation.⁷⁷

Measuring the State Economy

Like the national economy, there are similar ways to analyze Oregon’s economy: GDP and employment are important, as information specific to Oregon’s industries.

i. Gross Domestic Product

State GDP Like the national GDP, Oregon’s GDP is a measure of how much the state produces in goods and services.

Past Trends Since Central Point’s first economic element in 1980, Oregon’s economy has transitioned from being a resource-based economy (traditionally timber, fishing, and agriculture) to being a more mixed manufacturing and marketing economy (with an emphasis on high technology).⁷⁸ At the same time, Oregon’s GDP has more than doubled, from \$100.8 billion in 1997 to \$212.6 billion in 2017. See **Figure 7** for Oregon’s GDP increase.

Figure 7: Oregon GDP 1997-2017

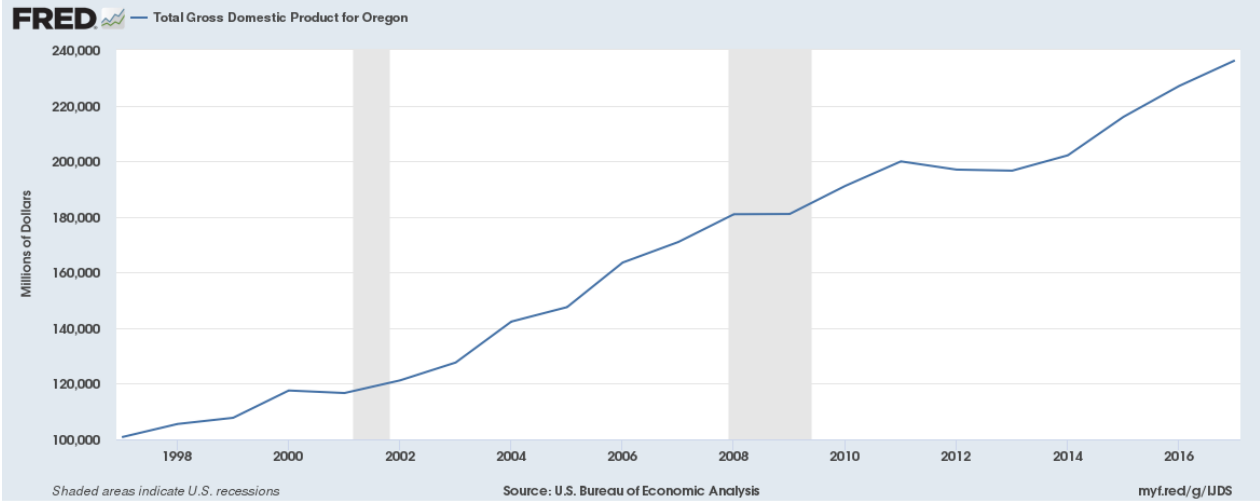

⁷⁵ Adam Nagourney and Matt Stevens, *California Today: The State Faces Some Big Problems. Are We Ready?* New York Times (Oct. 11, 2018), available at: www.nytimes.com/2018/10/11/us/california-economy.html.

⁷⁶ Oregon Small Business Association Foundation, *Oregon #12 in nation’s Best State Economies*, Oregon Business Report (Oct. 15, 2018).

⁷⁷ *Id.*

⁷⁸ Oregon Secretary of State, *Oregon Facts*, Oregon Blue Book: Almanac & Fact Book, available at: sos.oregon.gov/blue-book/Pages/facts/economy-overview.aspx.

Attachment: Economic Element (6/27/2019) (1163 : Economic Element)

Recent growth In the the last five years, Oregon’s has had slightly above average economic growth in comparison to other states: its GDP has grown 1.7 percent, the 16th largest increase in the country, ranking it 24th in the nation.⁷⁹

Short-term projection Although there is the possibility that the state economy will continue booming, it is more likely that the state will experience a mild recession around 2020. See **Figure 8** for three likely scenarios for the state economy. The Oregon Economic and Revenue Forecast of September 2018 anticipates that under the mild recession scenario, the economy will contract by -1.8 percent in 2020 and -0.6 percent in 2021.⁸⁰ Absent a recession, the state’s Real Gross State Product is projected to be the seventh fastest among all states across the country in terms of growth with gains averaging 2.5 percent through 2023.⁸¹

Figure 8: Short-Term Economic Scenarios for Oregon⁸²

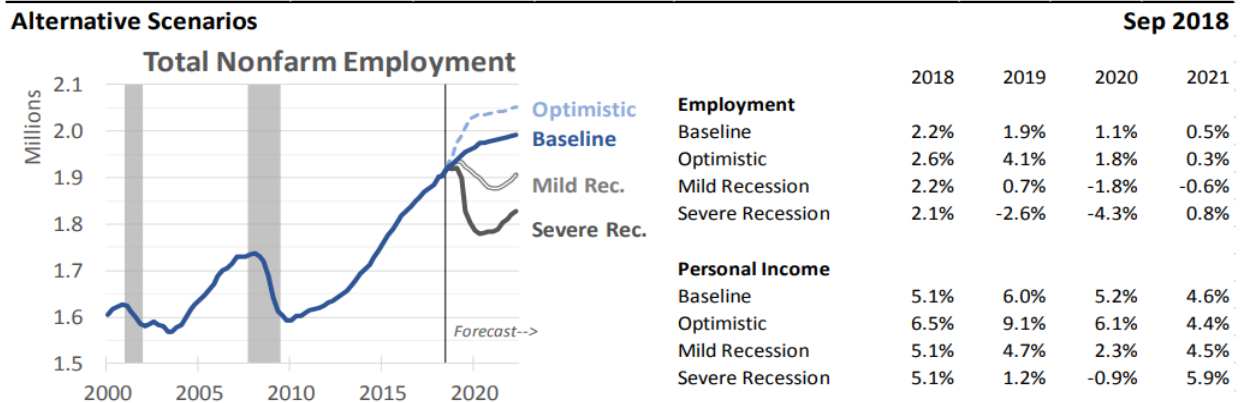

Long-term projection Even if there is a recession in the coming years, the economy should recover and continue to do well into the long-term.

Conclusion Like the national economy, the state economy should remain healthy over the next year. However, there is a strong potential that a national recession will spill over into Oregon, damaging the state economy and harming Oregon residents.

ii. Employment

Overview Oregon has more than two million people in its labor force.⁸³ Through 2023, the state economy’s total employment is expected to be the eighth strongest among all the states at a rate of 1.3 percent.⁸⁴

Past Trends Nearly every state industry was affected by the Great Recession but by May 2016, Oregon had more jobs than it had when the recession began.⁸⁵ See **Figure 9**, which shows how

⁷⁹ *Id.*
⁸⁰ Oregon Economic and Revenue Forecast, XXXVIII, No. 3, at 16 (Sept 2018).
⁸¹ *Id.* at 21.
⁸² *Id.*
⁸³ Oregon Secretary of State, *Oregon Facts*, Oregon Blue Book: Almanac & Fact Book.
⁸⁴ Oregon Economic and Revenue Forecast, XXXVIII, No. 3, at 21 (Sept 2018).
⁸⁵ *Id.*

the state unemployment rate has changed depending on the national economic environment.

Figure 9: Oregon’s Unemployment Rate

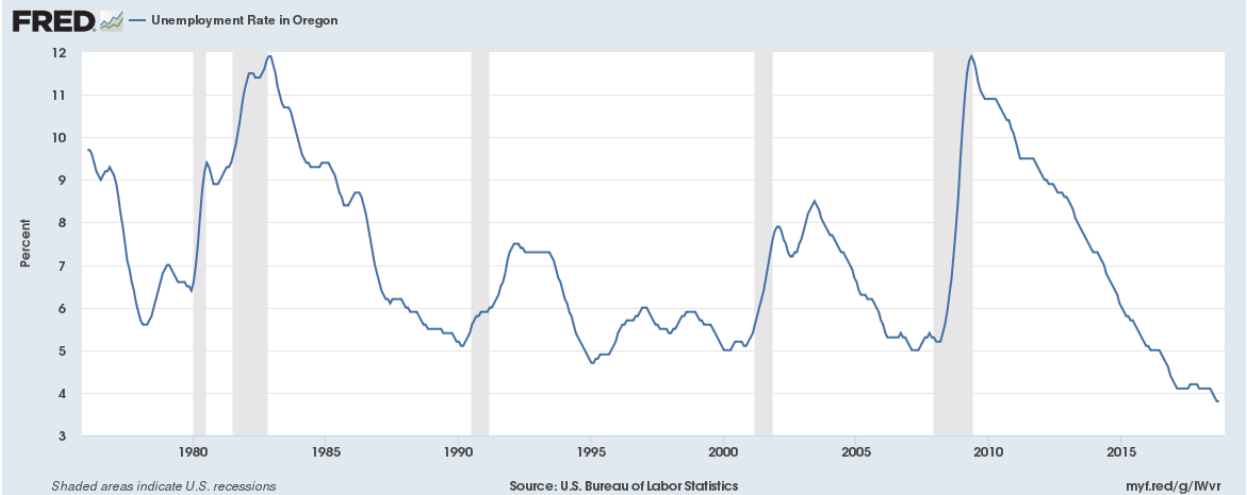

Recent trends Currently, Oregon’s unemployment number is under what is historically considered full employment for the state.⁸⁶ However, for the last three years, the unemployment rate has been extremely volatile; a few months of extreme declines have been followed by months of huge increases.⁸⁷ However, over the last year the Oregon unemployment rate has stopped declining.⁸⁸ Currently, it is hovering around 4 percent.

Short-term projections The Oregon Office of Economic Analysis projects that the Oregon unemployment rate will remain steady for the near future because this job growth rate now matches population and labor force gains.⁸⁹ However, if there is a severe recession in the near-future, unemployment may spike up to 10 percent.⁹⁰

Long-term projections The Oregon Office of Economic Analysis projects a “slightly stronger economic outlook” in 2025 and beyond.⁹¹ Compared to the rest of the country, Oregon’s employment numbers should fare well. Total employment could be the eighth strongest in the nation at 1.3 percent, while manufacturing employment could be the seventh fastest in the country at 1.1 percent.⁹²

Conclusion Based on the economic reports created by the oregon Office of Economic Analysis, the Oregon unemployment rate should remain steady for the near future. However, depending on the strength of the anticipated 2020 slowdown, this could change dramatically. If Oregon’s economy is lucky enough to avoid being harmed by the national economy, the unemployment rate should continue to decrease to near-record levels.

⁸⁶ *Id.* at 10.
⁸⁷ *Id.*
⁸⁸ *Id.*
⁸⁹ *Id.*
⁹⁰ Oregon Economic and Revenue Forecast, XXXVIII, No. 3, at 20 (Sept 2018).
⁹¹ *Id.* at 15.
⁹² *Id.* at 21.

iii. Industry Strengths

Another way to understand the state economy is to see how the state's population is employed. **Figure 10** list the most common jobs in Oregon, as well as the normal wages. Location Quotient ("LQ") shows the relative strength of that occupation in Oregon's economy. For example, if an LQ is greater than one it indicates that the concentration is greater in Oregon than the national average. If it is less than one, it indicates that Oregon has a lower concentration than on average.

Figure 10: Oregon Occupational Employment and Wage Estimates from May 2016⁹³

| Occupation title | Employment | Employment per 1,000 jobs | LQ | Median hourly wage | Annual mean wage |
|--|------------|---------------------------|------|--------------------|------------------|
| All Occupations | 1,790,940 | 1000 | 1 | \$18.26 | \$49,710 |
| Office and Administrative Support | 265,770 | 148.399 | 0.95 | \$16.96 | \$37,430 |
| Sales and Related | 181,760 | 101.488 | 0.98 | \$13.45 | \$37,980 |
| Food Preparation and Serving Related | 170,710 | 95.32 | 1.03 | \$10.98 | \$25,190 |
| Transportation and Material Moving | 119,650 | 66.806 | 0.96 | \$15.73 | \$36,550 |
| Production | 113,230 | 63.226 | 0.97 | \$16.47 | \$37,460 |
| Management | 110,970 | 61.96 | 1.23 | \$42.91 | \$102,990 |
| Education, Training, and Library | 103,930 | 58.031 | 0.94 | \$23.01 | \$57,450 |
| Healthcare Practitioners and Technical | 98,610 | 55.061 | 0.93 | \$38.16 | \$90,100 |
| Business and Financial Operations | 83,790 | 46.788 | 0.9 | \$29.96 | \$68,530 |
| Construction and Extraction | 72,580 | 40.526 | 1.02 | \$22.45 | \$50,820 |
| Personal Care and Service | 69,360 | 38.726 | 1.2 | \$11.98 | \$27,900 |
| Installation, Maintenance, and Repair | 61,940 | 34.587 | 0.89 | \$21.21 | \$47,190 |
| Retail Salespersons | 61,610 | 34.402 | 1.07 | \$11.85 | \$28,890 |
| Building and Grounds Cleaning and Maintenance | 55,400 | 30.931 | 0.98 | \$12.77 | \$29,350 |
| Computer and Mathematical Occupations | 50,900 | 28.419 | 0.96 | \$37.72 | \$82,190 |
| Healthcare Support | 48,130 | 26.877 | 0.93 | \$16.24 | \$35,110 |
| Cashiers | 45,730 | 25.535 | 1.01 | \$11.03 | \$24,640 |
| Architecture and Engineering | 40,820 | 22.795 | 1.28 | \$37.31 | \$86,810 |
| Community and Social Service | 35,930 | 20.061 | 1.39 | \$20.68 | \$46,490 |
| Registered Nurses | 35,220 | 19.667 | 0.97 | \$42.32 | \$87,000 |
| Combined Food Preparation and Serving Workers, Fast Food | 34,950 | 19.518 | 0.8 | \$10.55 | \$22,930 |
| Office Clerks, General | 33,500 | 18.707 | 0.89 | \$15.90 | \$34,470 |
| Waiters and Waitresses | 33,100 | 18.48 | 1.01 | \$10.62 | \$26,240 |
| Protective Service | 32,740 | 18.283 | 0.76 | \$22.29 | \$50,010 |

⁹³ Bureau of Labor and Statistics, *May 2016 State Occupational Employment and Wage Estimates Oregon*, Department of Labor (May 2016), available at: www.bls.gov/oes/2016/may/oes_or.htm#00-0000.

The state agency Business Oregon lists six target industries for the state economy: Forestry & Wood Products, Advanced Manufacturing, High Technology, Food & Beverage Services, Business Services, and Outdoor Gear & Apparel.⁹⁴

Oregon continues to be a leader in forestry and agriculture. While the Oregon economy is much more diverse than it was thirty years ago, forestry and agriculture still exhibit employment that is concentrated at many times the national average. However, the timber industry is under pressure from both the market and federal regulations, and so is projected to grow slowly.⁹⁵

Oregon's manufacturing industry is weighted towards semiconductors and wood products relative to the nation, which mostly concentrates on autos and aerospace.⁹⁶ Although semiconductors and wood products have been historically strong, they are expected to grow more slowly in the future.⁹⁷ The state's primary metal manufacturing is concentrated as a result of the continued operation of Oregon's aluminum industry.

The computer and electronic product manufacturing industries are strong due to the presence of Intel and Tektronix in the Portland area. Non-store retailers like Harry & David contribute to the strength in that industry sector. Beverage manufacturing comes from the growing wine and craft beer industries in Oregon.

Professional and Technical Services is a fast-growing, emerging industry in Oregon.⁹⁸ It includes businesses who are using their expertise to help businesses around the world to grow.⁹⁹ Management and technical consulting is the largest industry in this group, followed by engineering services and advertising, public relations, and related services.¹⁰⁰ For example, CH2M was founded in Corvallis and now employs over 26,000 employees worldwide.¹⁰¹

While Oregon is not known as a home for Fortune 500 companies, it does have Nike, a world-leader in shoes and athletic apparel. The City of Portland is also the home of Columbia Sportswear, which specializes in the target industry of Outdoor Gear & Apparel.

The Office of Economic Analysis has ranked eleven industries as doing exceptionally well. Private sector food manufacturing, education, and health care have never suffered strong losses from a recession.¹⁰² Further, retail employment, wholesale, transportation, warehousing and utilities, and construction have surpassed their pre-recession levels and are at all time highs.¹⁰³

⁹⁴ Business Oregon, *Business Oregon's Target Industry Groups*, available at: www.oregon4biz.com/Oregon-Business/Industries/.

⁹⁵ Oregon Economic and Revenue Forecast, XXXVIII, No. 4, at 17 (Nov. 2018).

⁹⁶ *Id.*

⁹⁷ *Id.*

⁹⁸ Business Oregon, *Business Oregon's Target Industry Groups*, available at www.oregon4biz.com/Oregon-Business/Industries/.

⁹⁹ *Id.*

¹⁰⁰ *Id.*

¹⁰¹ *Id.*

¹⁰² Oregon Economic and Revenue Forecast, XXXVIII, No. 3, at 8 (Sep. 2018).

¹⁰³ *Id.*

State Economic Crosscurrents:

Primary Risks to Oregon's Economy The state economy appears healthy: GDP is good, unemployment is low, and Oregon's industries are strong and growing. However, the state economy is at risk: the national economy could experience a small recession that could drag down the state economy, trade wars threaten the state's economic vitality, there is a housing crisis, and wildfires and smoke are harming the tourism industry.

i. The National Economy

Because of the potential for an economic slowdown around 2020, it is important to analyze the impacts that the last national recessions had on the Oregon economy. In fact, Josh Lehner of the Oregon Office of Economic Analysis forecasts that a future recession would be like the 1990s recession,¹⁰⁴ so it is important to review how that particular economic event effected the state economy.

The 1990s recession was relatively mild on the national economy.¹⁰⁵ In the 1990s, Oregon "lost just as many jobs as the US did."¹⁰⁶ However, many consumer service sectors and industries actually outperformed the US economy.¹⁰⁷ This included manufacturing, construction, services, and retail. Nevertheless, the data indicates that there were big manufacturing job losses, with less losses in the service sectors.¹⁰⁸ As a result, if there is a recession around 2020 and it appears to be similar to the 1990s recession, Oregon should brace itself for losses in the manufacturing industry, but for the industry to be able to hunker down and withstand a short economic storm.

ii. Trade Wars

Oregon is particularly susceptible to harm from a trade war because Oregon trades more with foreign nations than most other states.¹⁰⁹ As a result, should China and Canada retaliate against US trade tariffs, Oregon's economy could be dealt a particularly strong blow.¹¹⁰ According to economist Josh Lehner of the Oregon Office of Economic Analysis, the impact of tariffs from China and Canada to Oregon's economy could be about \$870 million.¹¹¹ It has the potential to impact the state's agriculture industry, aluminum scrap exporters, various consumer goods, and distillery companies.¹¹² If there is continued escalation and if global supply chains are disrupted, "it will be a much bigger economic problem."¹¹³

¹⁰⁴ Josh Lehner, *Hammer Don't Hurt 'Em*, Oregon Office of Economic Analysis (Oct. 26, 2018), available at: oregoneconomicanalysis.com/2018/10/26/hammer-dont-hurt-em/.

¹⁰⁵ *Id.*

¹⁰⁶ *Id.*

¹⁰⁷ *Id.*

¹⁰⁸ *Id.*

¹⁰⁹ Kathleen McLaughlin, *Tariff hikes hit Oregon products*, The Bend Bulletin (June 19, 2018), available at: www.bendbulletin.com/business/6322636-151/tariff-hikes-from-china-canada-hit-oregon-products.

¹¹⁰ *Id.*

¹¹¹ *Id.*

¹¹² *Id.*

¹¹³ *Id.*

iii. Housing Affordability

Oregon is in a housing crisis. Since Central Point adopted its first Economic Element in 1980, housing prices in Oregon have risen by 315%, making it 4th in the nation for housing price increases.¹¹⁴ A major issue is that Oregon is not building enough housing units to keep pace with the population increase. According to the Oregon Home Builders Association Oregon needs 25,000 new units every year, but only 15,000 are being constructed.¹¹⁵

Low housing supply has led to rising rental costs and home prices. This, plus a very low rental vacancy rate, have contributed to an affordable housing crisis across the state.¹¹⁶ According to the National Low Income Housing Coalition, Oregon is the 3rd most unaffordable rental market in the nation.¹¹⁷ Further, according to the Oregon Housing and Community Services Director Margaret Van Vliet, the state has 130,000 extremely low-income households but only 20,000 housing units are affordable for those households.¹¹⁸

This crisis is straining the state economy because housing is a necessary expenditure. If 55 percent of renters in Oregon must pay more than 30 percent of their income to housing,¹¹⁹ then Oregon consumers will have less purchasing power. Further, if there is not enough housing, Oregon will have fewer workers and will be less able to entice target industries to relocate.

iv. Wildfires and Smoke

Wildfires and smoke have been negatively impacting the Oregon economy.¹²⁰ The last two years have had record levels of unhealthy air. According to the Oregon Department of Forestry's 2018 fire statistics 70,685 of the acres that it protects burned as of September 2018, which is 53 percent higher than the 10-year average.

A wildfire impact study released by Travel Oregon in July 2018 found that the state lost \$51.5 million in visitor spending due to the 2017 wildfires.¹²¹ According to the study, Josephine County lost \$680,000 and Jackson County lost \$2.8 million in spending because of the fires. Those losses were mostly in the food service and accommodation industries.¹²² The smoke also cost the Oregon Shakespeare Festival in Ashland about \$2 million as a result of cancelling outdoor performances.¹²³

¹¹⁴ Habitat for Humanity, *Oregon's Housing Crisis*, available at: habitatoregon.org/affiliates/oregons-housing-crisis/

¹¹⁵ *Id.*

¹¹⁶ Vickie Aldous, *Merkley: Oregon is in a housing crisis*, Medford Mail Tribune (March 30, 2018), available at: mailtribune.com/news/top-stories/merkley-oregon-is-in-a-housing-crisis.

¹¹⁷ Habitat for Humanity, *Oregon's Housing Crisis*.

¹¹⁸ Vickie Aldous, *Merkley: Oregon is in a housing crisis*.

¹¹⁹ Habitat for Humanity, *Oregon's Housing Crisis*.

¹²⁰ KATU Staff, *Wildfires, smoke taking its toll on Oregon tourism*, KATU (Aug. 14, 2018), available at: katu.com/news/local/wildfires-smoke-taking-its-toll-on-oregon-tourism.

¹²¹ Saphara Harrel, *The News-Review* (Sep. 17, 2018), available at: www.nrtoday.com/news/environment/wildfires/wildfires-impact-the-health-economy-of-southern-oregon/article_f34eff89-4681-5da3-9714-ada8b91a8cd9.html.

¹²² *Id.*

¹²³ Peter Libbey, *Wildfire Smoke Disrupts Oregon Shakespeare Festival*, New York Times (Aug. 24, 2018), available at: www.nytimes.com/2018/08/24/theater/oregon-shakespeare-festival-wildfire-smoke.html.

Section 4: Economic Trends in Southern Oregon

Overview Central Point is located in Jackson County and near Josephine County. Both counties effect Central Point's economy and are often treated as a single region for economic data.

*Jackson County*¹²⁴ It has a population of 219,270 people as of May 2018,¹²⁵ which accounts for approximately 5 percent of Oregon's population.¹²⁶ Between 2000 and 2010, it experienced a 1.1 percent increase in population¹²⁷ and a 5.26 percent increase in median household income, from \$44,028 to \$46,343.¹²⁸ Its median age is 42.9.

Southern Oregon The Office of Economic Analysis has stated that Southern Oregon was hit hard by the Great Recession and that the recovery has been more difficult than other parts of the state.¹²⁹ However, local job growth has returned, and poverty rates are falling. While Jackson County has historic highs in wage growth and employment rates, Josephine County is still in a bad position, having yet to regain its losses from the last recession.¹³⁰

i. Gross Domestic Product

Jackson County had the 103rd fastest growth in GDP between 2016 and 2017 among the nation's 384 metropolitan areas (2.6 percent).¹³¹ This is compared to the U.S. metropolitan areas growing by an average of 2.1 percent during the same time frame.¹³² The U.S. Bureau of Economic Analysis has projected that the county had a GDP of \$8,590,000,000 for 2017.¹³³

Industries in Jackson County that boosted GDP growth were education and health services; professional and business services; trade; and transportation, warehousing, and utilities.¹³⁴ *See Figure 11.* Those industries that damaged GDP growth were other services and information.¹³⁵

¹²⁴ Officially labeled "Medford OR (MSA)" (the Medford, Oregon Metropolitan Statistical Area).

¹²⁵ Population Research Center, Portland State University, *Jackson County Final Forecast Report*, Cycle 2: Region 1 Documents 8 (May 2018), available at: www.pdx.edu/prc/sites/www.pdx.edu/prc/files/Jackson_Report_Final.pdf (PDF warning).

¹²⁶ $210,916/4,142,000 = 5.09\%$

¹²⁷ Population Research Center, Portland State University, *Jackson County Final Forecast Report*, Cycle 2: Region 1 Documents 8 (May 2018), available at: www.pdx.edu/prc/sites/www.pdx.edu/prc/files/Jackson_Report_Final.pdf (PDF warning).

¹²⁸ *Medford, OR Metro Area*, Data USA, available at: <https://datausa.io/profile/geo/medford-or-metro-area/#intro>.

¹²⁹ Oregon Economic and Revenue Forecast, XXXVIII, No. 4, at 20 (Nov. 2018).

¹³⁰ *Id.*

¹³¹ Guy Tauer, *Medford and Grants Pass GDP Growth Outpace U.S. Average in 2017*, QualityInfo (Sept. 27, 2018), available at: www.qualityinfo.org/-/medford-and-grants-pass-gdp-growth-outpace-u-s-average-in-2017.

¹³² *Id.*

¹³³ Bureau of Economic Analysis, Department of Commerce, *New Release: Gross Domestic Product by Metropolitan Area, 2017* (Sep. 18, 2018), available at: www.bea.gov/system/files/2018-09/gdp_metro0918_0.pdf (PDF warning).

¹³⁴ *Id.*

¹³⁵ *Id.*

**Figure 11: Changes to Jackson County’s GDP¹³⁶
Medford MSA (Jackson County) Industry
Contribution to GDP Growth**

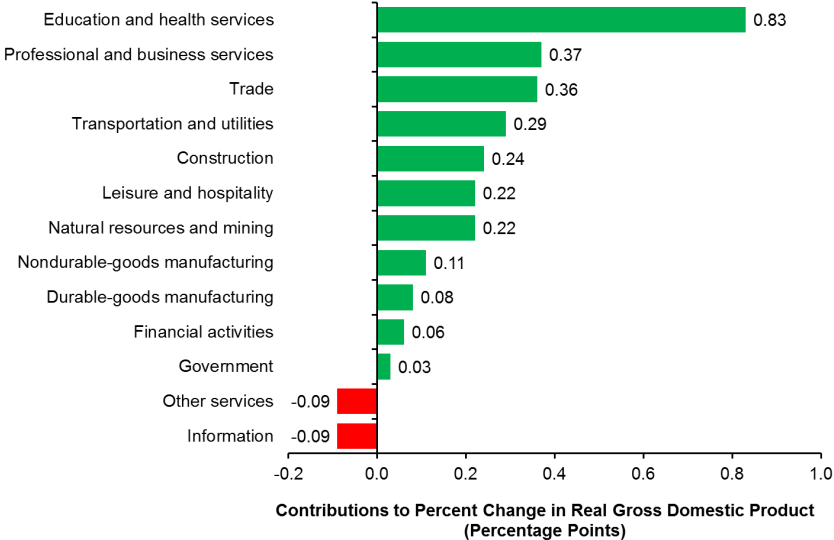

The U.S. Bureau of Economic Analysis has projected that Josephine County had a GDP of \$2,478,000,000 for 2017.¹³⁷ Incredibly, this ranked it 31st in the nation in terms of fastest growth in GDP for 2017.¹³⁸ During that time, the GDP grew at 4.3 percent.

**Figure 12: Changes to Josephine County’s GDP¹³⁹
Grants Pass MSA (Josephine County) Industry
Contribution to GDP Growth**

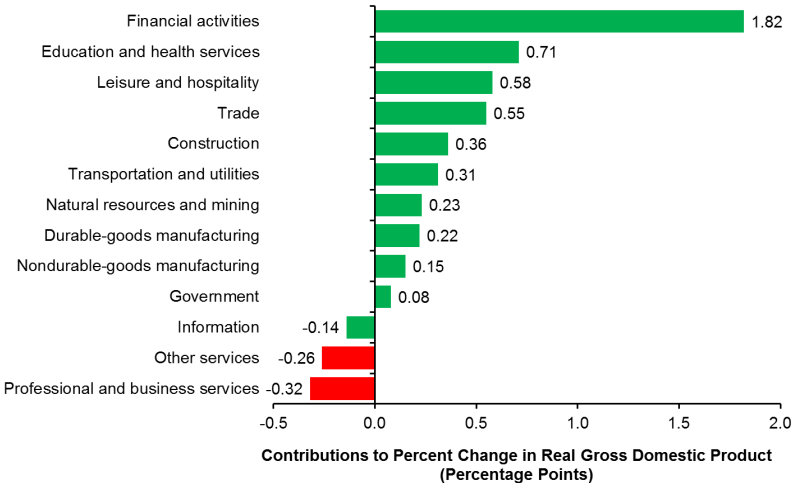

In Josephine County, 40 percent of GDP growth came from finance, insurance, and real estate.¹⁴⁰

¹³⁶ Guy Tauer, *Medford and Grants Pass GDP Growth Outpace U.S. Average in 2017*.
¹³⁷ Bureau of Economic Analysis, Department of Commerce, *New Release: Gross Domestic Product by Metropolitan Area, 2017* (Sep. 18, 2018), available at: www.bea.gov/system/files/2018-09/gdp_metro0918_0.pdf (PDF warning).
¹³⁸ *Id.*
¹³⁹ Guy Tauer, *Medford and Grants Pass GDP Growth Outpace U.S. Average in 2017*.
¹⁴⁰ *Id.*

Attachment: Economic Element (6/27/2019) (1163 : Economic Element)

Other industries that are strong are trade, education and health services (like in Jackson County), and leisure and hospitality. See **Figure 12**. Professional and business services, information, and other services reduced the GDP.

Conclusion Southern Oregon’s economy is growing at a good pace. Both Jackson and Josephine County are well ranked nationally in terms of the rate of economic growth. However, they both have a long way to go to recover from the losses they suffered in the Great Recession.

ii. Employment

Recent Trends Southern Oregon was recently ranked in the top 30 job markets in the United States based on job growth over the last five years.¹⁴¹ USA Today ranked the nearby City of Medford as #28 in the nation, saying:

Medford is one of several rapidly growing cities in Oregon adding jobs at a faster pace than almost anywhere else in the country. Due in large part to the metro area's education and health services industry, there are over 13,000 more jobs in Medford today than there were in 2013, a 15.4 percent increase.¹⁴²

USA Today also said that Grants Pass had the largest drop in unemployment in the nation between 2013 and 2018, ranking it as the 18th best job growth economy in the nation.¹⁴³ Job growth was driven by the education and health services industry, which added 1,700 out of the 5,000 new jobs.¹⁴⁴

Figure 13: Jackson County Unemployment Rate

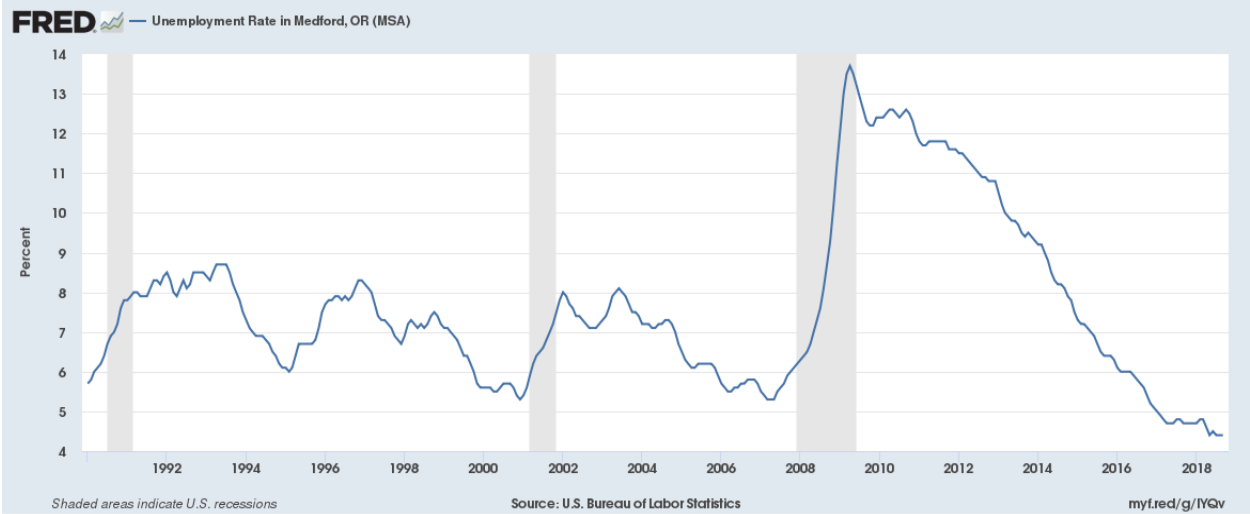

¹⁴¹ Jamie Parfitt, Report: Medford, Grants Pass among top us job markets, Newswatch 12 (Nov. 13, 2018), available at: www.kdrv.com/content/news/Report-Medford-Grants-Pass-Among-Top-US-Job-Markets-500405392.html.

¹⁴² Samuel Stebbins, *31 cities adding the most jobs as the US economy grows*, USA Today (Nov. 12, 2018), available at: www.usatoday.com/story/money/economy/2018/11/12/us-economy-grows-cities-adding-most-jobs/38319445/.

¹⁴³ *Id.*

¹⁴⁴ *Id.*

Despite this new growth, Jackson County's unemployment rate is still higher than the national average.¹⁴⁵ In fact, both Jackson and Josephine County had the highest unemployment rates out of all the cities in the USA Today's list of best local economies.¹⁴⁶ However, when compared to other regions in Oregon, Jackson County has one of the lowest unemployment rates at 4.4 percent.¹⁴⁷ See **Figure 13**. Neighboring Josephine County is at 5.5 percent while Klamath County is at 5.8 percent.¹⁴⁸

Conclusion The Southern Oregon economy is growing at a very good rate. While it still needs to catch up to the rest of the nation,¹⁴⁹ if it is able to avoid being harmed too much by the next economic slowdown, it should be able to make up its past losses.

iii. Housing

Overview For the last few years the local housing market has been booming. However, it now appears to be slowing down. This is a major concern for the Southern Oregon economy because it may inhibit construction of much-needed housing units and continue to drive up the price of rent.

Recent trends Between 2000 and 2010, the total number of housing units in Jackson County increased rapidly.¹⁵⁰ Housing units increased by 20.1 percent, with 2,130 units in Central Point alone (almost half of Medford's growth of 5,000 units).¹⁵¹ In 2018 home prices in Jackson County increased by an average of \$12,000 in comparison to 2017, a slower rate than previous years.¹⁵²

Conclusion Southern Oregon is one of the last affordable housing areas in the West Coast.¹⁵³ This could encourage Californians to relocate and contribute to the local economy.¹⁵⁴ However, new residents from wealthier states could encourage local builders to concentrate on constructing expensive homes and not affordable housing. This could price out younger people, such as Millennials, and portions of the working class from the region.

¹⁴⁵ Leah Thompson, *Southern Oregon's Unemployment Rates are Higher than Country's Average*, Newswatch 12 (Nov. 4, 2018), available at: www.kdrv.com/content/news/Southern-Oregons-Unemployment-Rates-are-Higher-than-Countrys-Average-499561461.html.

¹⁴⁶ Jamie Parfitt, *Report: Medford, Grants Pass among top us job markets*, Newswatch 12 (Nov. 13, 2018), available at: www.kdrv.com/content/news/Report-Medford-Grants-Pass-Among-Top-US-Job-Markets-500405392.html.

¹⁴⁷ *Id.*

¹⁴⁸ *Id.*

¹⁴⁹ *Id.*

¹⁵⁰ Population Research Center, Portland State University, *Jackson County Final Forecast Report, Cycle 2: Region 1 Documents 17* (May 2018), available at: www.pdx.edu/prc/sites/www.pdx.edu/prc/files/Jackson_Report_Final.pdf (PDF warning).

¹⁵¹ Matt Jordan, *Housing market 'softening' in Jackson County*, NBC 5 (Nov. 9, 2018), available at: kobi5.com/news/local-news/housing-market-softening-in-jackson-county-89532/.

¹⁵² Matt Jordan, *Housing market 'softening' in Jackson County*, NBC 5 (Nov. 9, 2018), available at: kobi5.com/news/local-news/housing-market-softening-in-jackson-county-89532/.

¹⁵³ Greg Stiles, *Housing prices will attract outsiders*, Medford Mail Tribune (Oct. 15, 2018), available at: mailtribune.com/business/housing-prices-will-attract-outsiders.

¹⁵⁴ *Id.*

Section 5: The City of Central Point's Trends

Introduction Central Point has unique economic and social trends when compared to the Southern Oregon region. Its population is fast-growing, relatively young, and its workers generally commute short distances to work.

Measuring the City's Trends

i. Commuting Patterns

Introduction The Department of Land Conservation & Development (DLCD) recommends analyzing commute patterns as one of the ways to determine land use needs.

Central Point exhibits a somewhat unique combination of commuting patterns. *See Figure 14.* Typically, cities that have a low percentage of its residents working within the city also have relatively high commute times. But that is not the case for Central Point, which has only 21 percent of its residence working outside the city. Those residents have much shorter commute times when compared to both the national and state averages for workers commuting outside their cities. This is probably because a large amount of Central Point residents work in north Medford. In many cases this is only a few blocks from where they live. Many may also work in White City, which can be accessed by roads with little congestion, such as Interstate 5 or Table Rock Road.

Figure 14: Central Point Resident Commuting Patterns¹⁵⁵

| Worker Travel Information (workers 16 years and over) | Oregon | Jackson County | Central Point |
|--|---------------|---------------------------|--------------------------|
| Means of Transportation to Work | | | |
| Car, truck, or van | 82.7% | 86.5% | 93.8% |
| Drove alone | 72.0% | 76.8% | 86.0% |
| Carpooled | 10.8% | 9.7% | 7.8% |
| Public transportation (excluding taxicab) | 4.2% | 0.9% | 1.5% ¹⁵⁶ |
| Walked | 3.9% | 3.4% | 2.0% |
| Bicycle | 2.1% | 1.4% | 1.4% |
| Taxicab, motorcycle, or other means | 1.0% | 1.0% | 0.2% |
| Worked at home | 6.1% | 6.7% | 2.7% |
| Travel Time to Work | | | |

¹⁵⁵ U.S. Bureau of the Census.

¹⁵⁶ The number of residents using public transportation was listed as 0.0% in the data set. However, that is improbable. Other Census Bureau data lists it as 1.5% and so that is included here. *See* U.S. Census Bureau, *ACS 5-year Estimate*, DataUSA (2016), available at: datausa.io/profile/geo/central-point-or/.

| | | | |
|------------------------------------|-------|-------|--------|
| Less than 10 minutes | 17.5% | 20.6% | 21.8% |
| 10 to 14 minutes | 16.9% | 22.2% | 29.7% |
| 15 to 19 minutes | 16.5% | 19.3% | 24.7% |
| 20 to 24 minutes | 15.0% | 15.2% | 11.2% |
| 25 to 29 minutes | 5.9% | 5.0% | 3.4% |
| 30 to 34 minutes | 11.9% | 8.8% | 5.5% |
| 35 to 44 minutes | 5.4% | 3.3% | 1.8% |
| 45 to 59 minutes | 5.6% | 2.9% | 0.4% |
| 60 or more minutes | 5.3% | 2.7% | 1.6% |
| Mean travel time to work (minutes) | 22.1 | 18.4 | 14.8 |
| Place of Work | | | |
| Worked in state of residence | 97.8% | 98.8% | 99.5% |
| Worked in county of residence | 77.5% | 94.9% | 97.7% |
| Worked outside county of residence | 20.3% | 3.9% | 1.8% |
| Worked outside state of residence | 2.2% | 1.2% | 0.5% |
| Living in a place | 79.4% | 74.3% | 100.0% |
| Worked in place of residence | 38.6% | 37.8% | 21.0% |
| Worked outside place of residence | 40.8% | 36.5% | 79.0% |
| Not living in a place | 20.6% | 25.7% | 0.0% |

ii. Local Population Forecast

Introduction In addition to reviewing commuting patterns and economic trends, it is also important to review trends related to population growth. The DLCDC recommends analyzing population because it is one of the best means to determine Central Point's future land demand.¹⁵⁷ While economic trends are subject to rapid changes without much warning, population growth is much easier to predict.

This section contains a short analysis of population trends as of 2019. For a more comprehensive analysis, see the Central Point *Population & Demographics Element (2019-2039)*.

Past Trends Since Central Point published its first Economic Element, Jackson County's total population has grown from roughly 114,000 to 219,270 people.¹⁵⁸ See **Figure 15**. The high growth rates of the 1970s were a result of relative economic prosperity while the decline in the 1980s was a result of challenging economic conditions.¹⁵⁹ During the 1990s, the county's growth rates increased again at first but then declined later in the decade. Jackson County's total population grew rapidly in the 2000s, with an average annual growth rate of just over 1 percent.

¹⁵⁷ Economic Development Planning Team, Oregon Department of Land Conservation and Development, *Tips for Conducting an Economic Opportunities Analysis* (March 2008).

¹⁵⁸ Population Research Center, Portland State University, *Coordinated Population Forecast: 2018 through 2068 (Jackson County)* (June 2018) at 8-9.

¹⁵⁹ *Id.*

Figure 15: Jackson County—Total Population by Five-year Intervals (1975-2017)¹⁶⁰

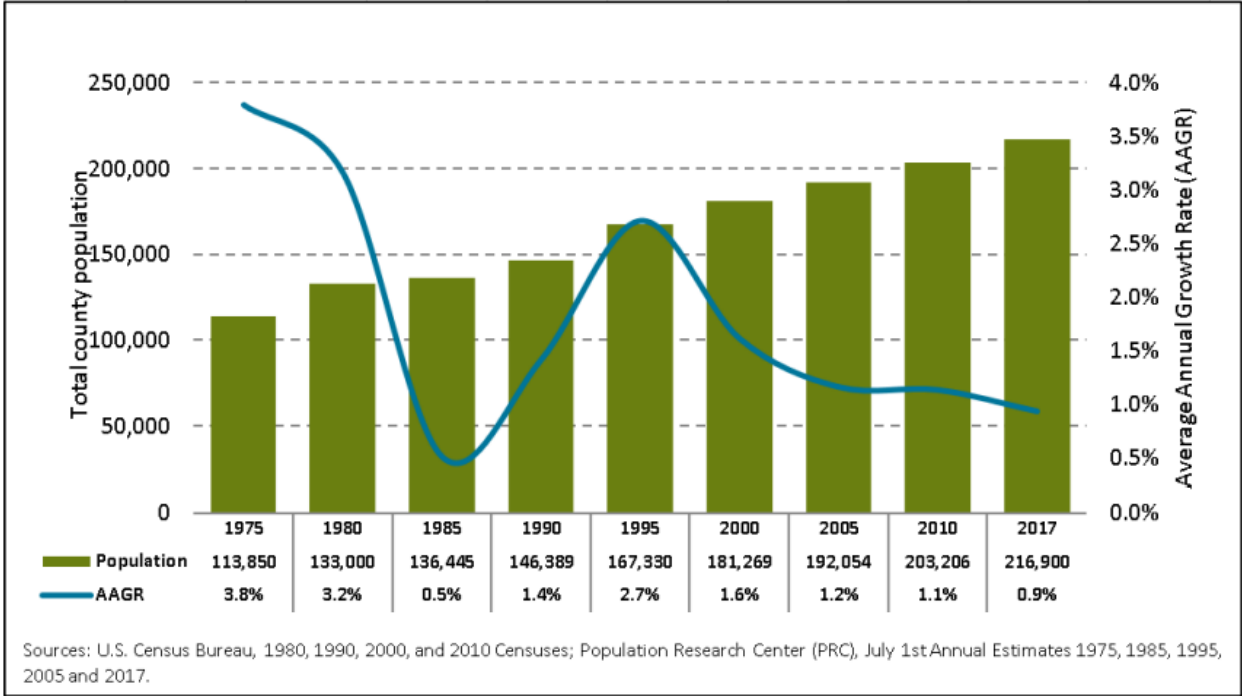

Central Point posted a growth rate higher than that of Jackson County, at 2.9 percent from 2000-2010.¹⁶¹ That makes it the second fastest growing area in the Rogue Valley, just after Eagle Point’s rate of 5.6 percent.¹⁶² Currently, Central Point has approximately 19,101 people,¹⁶³ ranking behind Medford’s 82,566 people and just behind the City of Ashland’s 21,501 people.¹⁶⁴

Reasons for Increase The county’s positive population growth has largely been the result of net immigration.¹⁶⁵ The aging population has led to an increase in deaths and local women have postponed having children, which has resulted in birth stagnation. As a result, without immigration, Southern Oregon would be experiencing a “natural decrease” in population.

Long-term projections Jackson County is likely to grow at a fast pace in the short-term.¹⁶⁶ The Central Point *Population & Demographics Element (2019-2039)* forecasts that Jackson County’s will grow from 219,270 people to 264,951 people by 2039.¹⁶⁷ See **Figure 16**.

¹⁶⁰ *Id.* at 10.
¹⁶¹ Population Research Center, Portland State University, *Jackson County Final Forecast Report, Cycle 2: Region 1 Documents* (May 2018), available at: www.pdx.edu/prc/sites/www.pdx.edu/prc/files/Jackson_Report_Final.pdf (PDF warning).
¹⁶² *Id.*
¹⁶³ See City of Central Point, *Population & Demographics Element (2019-2039)* at 12.
¹⁶⁴ Portland State University, Population Research Center, *Jackson County Coordinated Population Forecast 2018 through 2068*. Population Research Center, Portland State University, *Jackson County Final Forecast Report, Cycle 2: Region 1 Documents* (May 2018), available at: www.pdx.edu/prc/sites/www.pdx.edu/prc/files/Jackson_Report_Final.pdf (PDF warning) at 9.
¹⁶⁵ *Id.*
¹⁶⁶ *Id.*
¹⁶⁷ City of Central Point, *Population & Demographics Element (2019-2039)* at 13.

Attachment: Economic Element (6/27/2019) (1163 : Economic Element)

According to the Population Research Center at Portland State University, the City of Central Point is expected to capture a much larger share of Jackson County’s future population than it has in the past.¹⁶⁸ Central Point is expected to have a short-term growth rate of 1.5 percent,¹⁶⁹ and by 2039, Central Point will have 26,317 people, making it larger than the City of Ashland.¹⁷⁰ This also means that approximately 7 percent of the county population will live in Central Point.¹⁷¹

Figure 16: Population Growth Projections for City of Central Point and Jackson County¹⁷²

| Year | Central Point | Jackson County | Josephine County |
|-----------------------------|---------------|----------------|------------------|
| 2019 | 19,101 | 219,270 | 86,423 |
| 2020 | 19,714 | 235,066 | 88,274 |
| 2025 | 21,035 | 246,611 | 90,177 |
| 2030 | 22,920 | 257,256 | 93,194 |
| 2035 | 24,815 | 263,006 | 95,677 |
| 2039 | 26,317 | 264,951 | 97,377 |
| Change: 2019 to 2039 | 7,216 | 45,681 | 10,954 |

Figure 17: Central Point Population Pyramid¹⁷³

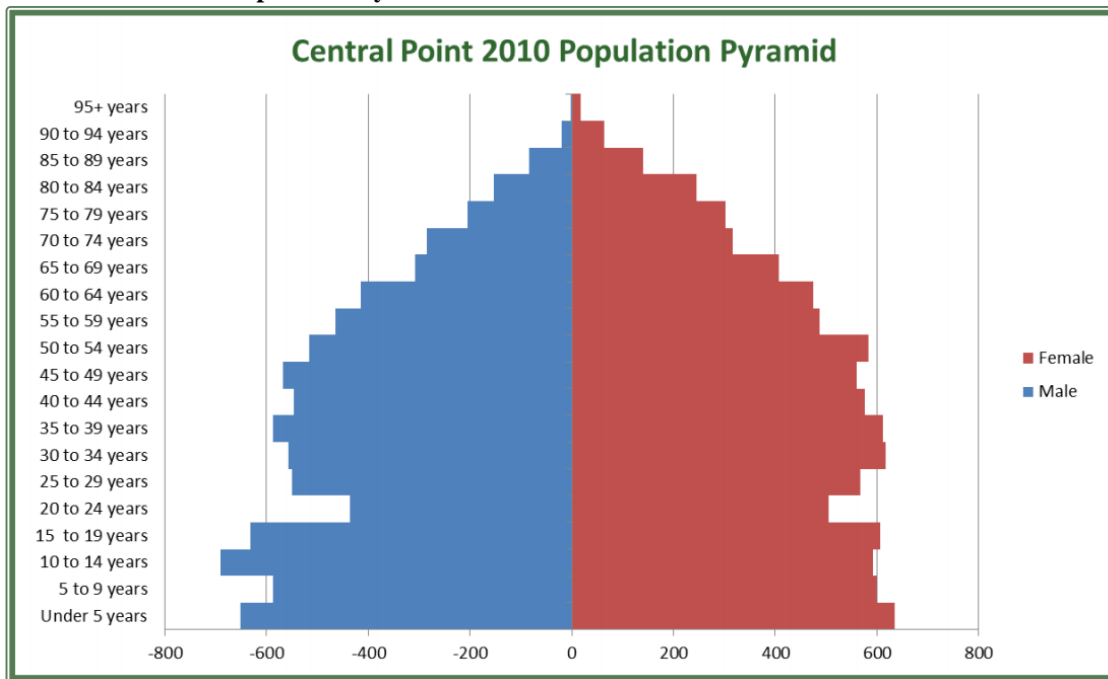

¹⁶⁸ Population Research Center, Portland State University, *Jackson County Final Forecast Report, Cycle 2: Region 1 Documents* (May 2018).

¹⁶⁹ *Population & Demographics Element (2019-2039)* at 13.

¹⁷⁰ *Jackson County Final Forecast Report, Cycle 2: Region 1 Documents* (May 2018) at 47.

¹⁷¹ *Population & Demographics Element (2019-2039)* at 12.

¹⁷² *Population & Demographics Element (2019-2039)* at 13, Table 1.

¹⁷³ City of Central Point Economic Element 2013-2033 *citing* U.S. Census Bureau.

The population pyramid for Central Point, *see* **Figure 17**, depicts the typical shape for a town without a university. The “gap” in residents aged 20-24 exists in most non-university towns because this is the age where young adults leave to attend college or obtain employment elsewhere. Although this data will be less valuable after the 2020 census, it still helps to predict what types of services and land use Central Point needs to offer. The City’s population is less top-heavy than either the nation or the county because fewer people aged 65 or older live in Central Point. Although the Southern Oregon region experiences high levels of retirees relocating to the area, this does not appear to be the case in Central Point. However, the ongoing Twin Creeks project may alter future data.

Because of the relative youth of the population, Central Point has a large percentage of families with working-aged individuals aged 30-50 and their children under the age of 14. Proportionally, this means that Central Point has higher levels of working-age individuals than the national population. This shows that Central Point has a strong labor base, and that there will continue to be a strong demand for education services.

Conclusion Central Point must prepare to have its population grow by almost 38% over the next 20 years. Should the population trends continue, the City must also be prepared to house a population younger than a typical non-university town.

iii. Regional Employment Forecast

Introduction The DLCDC also recommends analyzing job growth forecasts as a means to determine a city’s future land use needs.¹⁷⁴

The employment forecast data used in this section was generated by the Research Division at the Oregon Employment Department through 2027. This is the best region-specific data currently available. The following analysis correlates to both population growth per the City of Central Point *Population & Demographics Element (2019)* and the anticipated expansion of specific occupations and industries. The subsequent conclusions assume that the forecasted rates of 2017-2027 will remain constant through 2039.

Growth According to Guy Tauer, the Regional Economist for Jackson and Josephine counties, between 2017 and 2027, 14,111 new jobs will open in the “Rogue Valley region”¹⁷⁵ due to population growth.¹⁷⁶ In addition, there will be 148,807 job openings to replace workers who leave the occupation or the workforce.¹⁷⁷ A worker who leaves a job and then is hired to do the same job at another establishment would not be counted as a replacement opening.¹⁷⁸

¹⁷⁴ Economic Development Planning Team, Oregon Department of Land Conservation and Development, *Tips for Conducting an Economic Opportunities Analysis* (March 2008).

¹⁷⁵ Defined as Jackson and Josephine Counties.

¹⁷⁶ Guy Tauer, *Rogue Valley Employment Projections by Occupation 2017-2027*, State of Oregon Employment Department (July 9, 2018), available at: www.qualityinfo.org/-/rogue-valley-employment-projections-by-occupation-2017-2027.

¹⁷⁷ *Id.*

¹⁷⁸ *Id.*

Figure 18: Rogue Valley Occupational Employment Change, 2017-2027¹⁷⁹

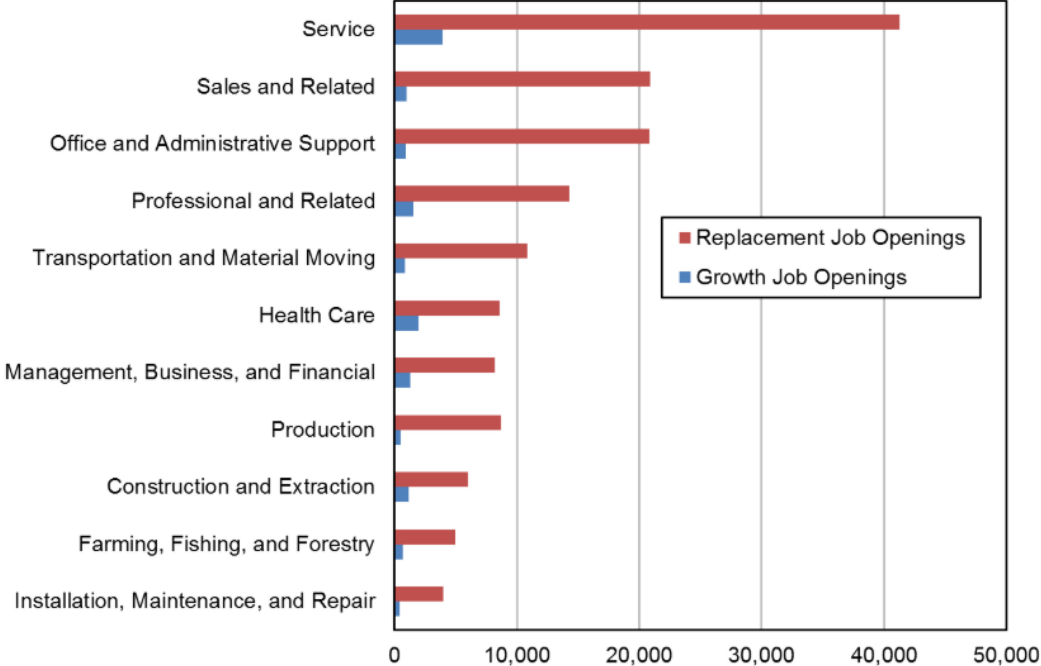

Service Industry The service industry had the largest share of total jobs in 2017. See **Figure 18** for both industry-specific job openings and job growth. The service industry is also expected to add the most new jobs in Jackson County and have the greatest number of total openings by 2027.¹⁸⁰ This industry includes food preparation, personal care services, building maintenance, ground keeping, and protective service occupations.¹⁸¹ This means that Central Point will need to dedicate more lands to retail use.

Sales and Related Industries After the service industry, the greatest total openings will be in sales and related industries, such as office and administrative support—each with approximately 21,800 total openings.¹⁸² These have growth rates of 6.7 percent and 5.3 percent.¹⁸³ This low growth forecast is probably a result of labor-saving technologies like self-checkout stations, automated inventory systems, and online retail sales.¹⁸⁴ This means that Central Point will need to dedicate additional lands to office use.

Health Care The health care and social assistance industries currently account for approximately one out of six jobs in the Rogue Valley.¹⁸⁵ In fact, the area’s current employment is concentrated in this industry with over 20,830 employees. Through 2027, health care is

¹⁷⁹ *Id.*
¹⁸⁰ *Id.*
¹⁸¹ *Id.*
¹⁸² *Id.*
¹⁸³ *Id.*
¹⁸⁴ *Id.*

¹⁸⁵ Guy Tauer, *Rogue Valley Employment Projections by Industry 2017-2027*, State of Oregon Employment Department (July 3, 2018), available at: www.qualityinfo.org/-/rogue-valley-employment-projections-by-industry-2017-2027.

expected to have the most job openings—adding 3,780 new jobs.¹⁸⁶ See **Figure 20** for industry-specific employment growth. This means that health care occupations will continue to grow by approximately 17.7 percent.¹⁸⁷ This is because a growing and aging population will demand more health care services, which will in turn create more employment opportunities in this recession-resistant industry.¹⁸⁸

Although health care in the Rogue Valley is mostly concentrated in Medford, given that it has both Asante Rogue Regional Medical Center and Providence Medford Medical Center, Central Point has begun to make inroads into the industry with the Providence Medical Plaza on North Pacific Highway. This indicates that Central Point may want to dedicate more land to office space use in order to house more health care workers.

Construction Over the decade, construction is expected to have the fastest job growth rate in the Rogue Valley, up by 25 percent. This is because housing construction, while still below pre-Great Recession levels, is picking back up.¹⁸⁹ As a result, Central Point may need more industrial-zoned land for construction shops, warehouses, machinery storage, and company offices.

Professional & Management, Business, and Financial The two industries of Professional and Related services and Management, Business, and Financial services will both be growing at a healthy rate. Professional and related occupations will have a growth rate of 10 percent. As a result, Central Point will want to dedicate a good amount of its employment lands for office space use.

¹⁸⁶ *Id.*

¹⁸⁷ *Id.*

¹⁸⁸ *Id.*

¹⁸⁹ *Id.*

Figure 19: Rogue Valley Industry Employment Change, 2017-2027¹⁹⁰

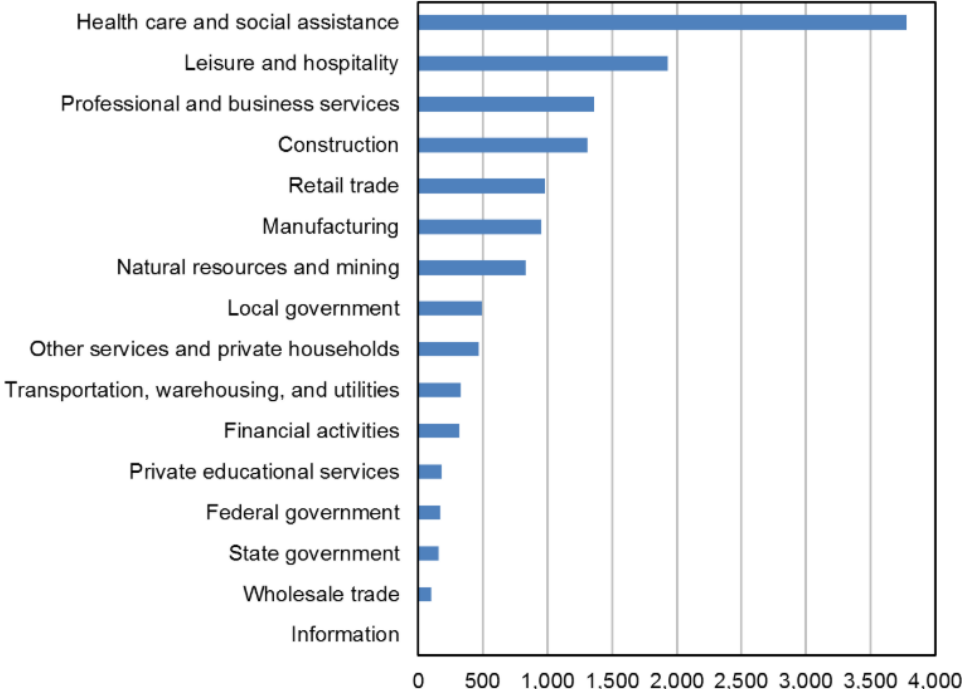

Manufacturing and retail Manufacturing and retail trade are still expected to add jobs by 2027, just under 1,000 for both industries.¹⁹¹ See **Figure 20** for industry employment changes. However, the possibility of an economic slowdown in these sectors should be taken into consideration when allocating land.

Leisure and hospitality About one in eleven jobs in the Rogue Valley were in leisure and hospitality in 2017.¹⁹² This tourism- reliant sector is forecast to add 1,930 jobs between 2017 and 2027.¹⁹³ However, Central Point should consider the devastating effects that wildfires and smoke could have on the industry in the near-future.

¹⁹⁰ Guy Tauer, *Rogue Valley Employment Projections by Industry 2017-2027*, State of Oregon Employment Department (July 3, 2018), available at: www.qualityinfo.org/-/rogue-valley-employment-projections-by-industry-2017-2027.

¹⁹¹ *Id.*

¹⁹² *Id.*

¹⁹³ *Id.*

Figure 20: Industry Employment Forecast, 2017-2027¹⁹⁴
Jackson and Josephine Counties

| Employment Sector | 2017 | 2027 | Change | % Change |
|--|----------------|----------------|---------------|---------------------|
| Total Employment | 123,190 | 137,610 | 14,420 | 12% |
| Total payroll employment | 116,030 | 129,390 | 13,360 | 12% |
| Total private | 101,750 | 114,290 | 12,540 | 12% |
| Natural resources and mining | 3,600 | 4,430 | 830 | 23% |
| Mining and logging | 550 | 570 | 20 | 4% |
| Construction | 5,290 | 6,600 | 1,310 | 25% |
| Manufacturing | 10,740 | 11,690 | 950 | 9% |
| Durable goods | 7,170 | 7,500 | 330 | 5% |
| Wood product manufacturing | 2,610 | 2,670 | 60 | 2% |
| Trade, transportation, and utilities | 25,020 | 26,430 | 1,410 | 6% |
| Wholesale trade | 3,190 | 3,290 | 100 | 3% |
| Retail trade | 18,110 | 19,090 | 980 | 5% |
| Transportation, warehousing, and utilities | 3,720 | 4,050 | 330 | 9% |
| Information | 1,410 | 1,410 | 0 | 0% |
| Financial activities | 5,310 | 5,630 | 320 | 6% |
| Professional and business services | 9,290 | 10,650 | 1,360 | 15% |
| Private educational and health services | 21,830 | 25,790 | 3,960 | 18% |
| Private educational services | 1,000 | 1,180 | 180 | 18% |
| Health care and social assistance | 20,830 | 24,610 | 3,780 | 18% |
| Health care | 18,480 | 21,710 | 3,230 | 17% |
| Leisure and hospitality | 14,580 | 16,510 | 1,930 | 13% |
| Accommodation and food services | 12,700 | 14,290 | 1,590 | 13% |
| Other services and private households | 4,680 | 5,150 | 470 | 10% |
| Government | 14,280 | 15,100 | 820 | 6% |
| Federal government | 2,010 | 2,180 | 170 | 8% |
| Federal government post office | 450 | 450 | 0 | 0% |
| State government | 2,750 | 2,910 | 160 | 6% |
| Local government | 9,520 | 10,010 | 490 | 5% |
| Local education | 6,790 | 7,160 | 370 | 5% |
| Self-employment | 7,160 | 8,220 | 1,060 | 15% |

Using the total employment data in **Figure 20**, we know how many people each industry employed in 2017 and a projection for those figures through 2027. As a result, we can calculate the annual job growth for the region per industry. Using the foregoing data, and assuming that the rates remain constant, a sample jobs forecast for the Rogue Valley region can be calculated through 2039, as seen in **Figure 21**.

¹⁹⁴ Guy Tauer, *Rogue Valley Industry Employment Projections* data (June 26, 2018), available at: www.qualityinfo.org/documents/10182/92203/Rogue+Valley+Industry+Employment+Projections+2017-2027?version=1.5 (Excel warning)

**Figure 21: Employment Growth Forecast
Jackson and Josephine Counties by Industry Sector**

| Industry Sector | Number of Jobs in 2017 ¹⁹⁵ | Number of Jobs in 2027 ¹⁹⁶ | Forecasted Change in Jobs through 2027 ¹⁹⁷ | Forecasted Annual Change in Jobs ¹⁹⁸ | Total Job Growth Forecast Southern Oregon 2019 through 2039 ¹⁹⁹ |
|--|---------------------------------------|---------------------------------------|---|---|--|
| Construction & Natural Resources | 8,890 | 11,030 | 2,140 | 214 | 4,280 |
| Manufacturing | 10,740 | 11,690 | 950 | 95 | 1,900 |
| Transportation & Utilities | 3,720 | 4,050 | 330 | 33 | 660 |
| Wholesale Trade | 3,190 | 3,290 | 100 | 10 | 200 |
| Subtotal Industrial Jobs | 26,540 | 30,060 | 3,520 | 352 | 7,040 |
| Retail Trade | 18,110 | 19,090 | 980 | 98 | 1,960 |
| Financial | 5,310 | 5,630 | 320 | 32 | 640 |
| Services (professional, business, health, private education, hospitality, information) | 47,110 | 54,360 | 7,250 | 725 | 14,500 |
| Subtotal Commercial/Services Jobs | 70,530 | 79,080 | 8,550 | 855 | 17,100 |
| Institutional/Government | 14,280 | 15,100 | 820 | 82 | 1,640 |
| Other | 11,840 | 13,370 | 1,530 | 153 | 3,060 |
| Total New Jobs | 123,190 | 137,610 | 14,420 | 1,442 | 28,840 |

In total, if the job growth rates projected for 2017-2027 are maintained for the next two decades, Southern Oregon will grow by 28,840 jobs by 2039.

iv. Regional Competitiveness

Generally, employers make locational decisions based upon a region's competitive position for their industry. They then choose between communities within that region based upon localized factors. So, identifying industries in which the region can become competitive is an important step in developing land use policies and strategies to capture economic development potential for which Jackson County is well positioned.

Figure 22: Jackson County Shift-Share Analysis 2010-2017¹⁹⁵

| Major Industry | LQ | | U.S. Growth rate ¹⁹⁶ | | Region Shift ¹⁹⁷ | |
|--------------------------------|------|------|---------------------------------|-----|-----------------------------|-------|
| | 2010 | 2017 | Percent | Net | Percent | Net |
| Farm Employment | 1.63 | 1.48 | 13.44 | 365 | -10.3 | -280 |
| Forestry, Fishing, and Related | 3.95 | 4.02 | 13.44 | 286 | 1 | 21 |
| Mining | 0.32 | 0.53 | 13.44 | 35 | 74.74 | 194 |
| Construction | 1 | 1.05 | 13.44 | 742 | 4.9 | 271 |
| Manufacturing | 0.9 | 1.08 | 13.44 | 924 | 20.57 | 1,414 |

¹⁹⁵ Pacific Northwest Regional Economic Analysis Project (PNREAP), Shift-Share Analysis of Employment Growth Jackson County, 2010-2017 (data analyzed Nov. 15, 2018), available at: oregon.reaproject.org/analysis/shift-share/tools/410029/2010/2017/.

¹⁹⁶ The change in local employment that would have occurred for a specific industry had it grown at the national growth rate of all industries combined.

¹⁹⁷ The additional gain (or loss) in local employment for a specific industry beyond the national growth and industry mix effects resulting from the industry growing faster (or slower) than the same industry nationally. This does not represent actual jobs lost but jobs that could have been created had the region kept up with the national growth rate.

| | | | | | | |
|--|----------|----------|--------------|---------------|--------------|---------------|
| Retail Trade | 1.4 | 1.39 | 13.44 | 2,079 | -1.45 | -225 |
| Transportation and Warehousing | 0.91 | 0.82 | 13.44 | 424 | -14.78 | -466 |
| Information | 1.09 | 0.79 | 13.44 | 298 | -29.55 | -655 |
| Finance and Insurance | 0.71 | 0.65 | 13.44 | 553 | -10.72 | -441 |
| Real Estate and Rental and Leasing | 1.19 | 1.16 | 13.44 | 773 | -3.52 | -203 |
| Professional, Scientific, and Technical Services | 0.71 | 0.71 | 13.44 | 712 | -1.82 | -96 |
| Management of Companies and Enterprises | 1.36 | 0.74 | 13.44 | 233 | -60.57 | -1,051 |
| Administrative and Waste Services | 0.83 | 0.77 | 13.44 | 729 | -9.23 | -501 |
| Educational Services | 0.55 | 0.6 | 13.44 | 190 | 10.04 | 142 |
| Health Care and Social Assistance | 1.28 | 1.31 | 13.44 | 2,064 | 2.11 | 324 |
| Arts, Entertainment, and Recreation | 1.37 | 1.34 | 13.44 | 441 | -3.53 | -116 |
| Accommodation and Food Services | 1.08 | 1.16 | 13.44 | 1,097 | 8.11 | 662 |
| Other Services (except Public Administration) | 0.98 | 0.98 | 13.44 | 810 | -0.54 | -32 |
| Federal Civilian | 0.93 | 0.98 | 13.44 | 239 | 4.74 | 85 |
| Military | 0.43 | 0.43 | 13.44 | 77 | -0.76 | -4 |
| State Government | 0.59 | 0.29 | 13.44 | 265 | -51.42 | -1,016 |
| Local Government | 0.78 | 0.86 | 13.44 | 940 | 8.99 | 629 |
| Other/Suppressed Industries ¹⁹⁸ | 0.69 | 0.69 | 13.44 | 384 | 0.07 | 2 |
| Total Employment | 1 | 1 | 13.44 | 14,662 | -1.23 | -1,343 |

See **Figure 22** for how specific industries are doing in the Rogue Valley as compared to the national average. The shift-share column (LQ) measures the degree to which an industry sector has outperformed the nation within that industry's employment levels during a specified time period. If the regional growth in an industry outpaced the change in the national share then there would be a positive (greater than 1) shift share.

If an industry sector has out-performed in a shift share analysis and the concentration within that industry also exceeds national averages in a Location Quotient (LQ) analysis, then those industries are likely to be ones for which the region has exhibited durable comparative advantages.

Between 2010 and 2017, the region outperformed the nation in nine industries. Of these, mining, manufacturing, educational services, and accommodation and food services outperformed the nation by at least eight percent. Mining had the highest percent gain in employment relative to the nation during the period, however given how little mining industry the area had previously, this comes out to a gain of only 194 new jobs. The second strongest shift came from manufacturing at 20.5 percent and with 1,414 new jobs.

¹⁹⁸ The "Other/Suppressed Industries" category portrayed in this table represents a combined total of those industries for which data were unavailable due to confidentiality restrictions. Those industries that are combined include: Utilities; Wholesale Trade.

There are three industries that the region is lagging in significantly: management of Companies and Enterprises, Information, and State Government. Management of Companies and Enterprises is a classification that involves employment in companies that run other types of smaller companies. Although the previous Economic Element indicated that the region was substantially ahead of the national curve (at 55 percent shift), the region is now significantly behind the national curve (at negative 60.57 shift). This makes sense given the somewhat remote location of the region from a major city and the levels of expertise that would typically be required in this type of industry.

The Information industry includes publishing, software, broadcast, and internet industries. It is unclear why the region is behind by almost 30 percent; however, it may have to do with the Southern Oregon region lacking a research university, which would attract younger information professionals. The relative proximity of Silicon Valley (less than 400 miles away) probably contributes to a brain-drain of these young workers. The lack of growth in State Government jobs makes sense because most of the Oregon governmental offices are in the state capital, Salem, or other parts of the Willamette Valley.

v. Economic Development Context

In addition to measuring economic data, Statewide Planning Goal 9 encourages cities to consider traits in their local economies that have yet to be numerically qualified. These traits are evaluated below through an analysis of Central Point’s strengths, weaknesses, opportunities, and threats.

Figure 23: Central Point’s Qualitative Trends¹⁹⁹

| Trait | Strengths | Weaknesses | Opportunities | Threats |
|---|---|---|--|---|
| Location, size, and buying power of markets | Relatively low percentage of large retail compared to population. National exposure with specialty food industry. | Relatively low per-household income. | If relative wages can be increased, Central Point can capitalize on expanding population. | Failure to capture proportional growth over time, especially in specialty foods. |
| Economic development efforts and programs | Direct communication and collaboration between City staff and local businesses. | Few large employers within city limits the role of the City in setting the policy and agenda for regional economic development. | If City can add a few large employers in a particular sector, the City will be able to drive regional policy in that area. | Capitalizing on this opportunity will require a coordinated strategy. |
| Transportation facilities | City has good freeway and airport access. | Central Point's I-5 interchange (Exit 33) is an old design with limited capacity. | Expansion of Exit 35 would add an additional freeway interchange and opportunities for key industries to locate there. | Growth around Exit 35 needs to help economic development without threatening the function of the interchange. |

¹⁹⁹ See City of Central Point, *Economic Element 2013-2033* (2013) citing City of Central Point.

| | | | | |
|--------------------------------|--|--|---|--|
| Public facilities and services | City has practical approach to its public facility needs and requirements. | City's water is supplied by the Medford Water Commission and sewage treatment is provided by the Regional Water Reclamation Facility operated by the City of Medford under long-term agreements. | City needs to ensure that it continues to have adequate capacity to serve future employment demands. | Maintaining a good relationship with the City of Medford and the Medford Water Commission is important to avoid future service disputes or too large an increase in rates. |
| Workforce development | City's workforce has access to Rogue Community College (RCC), Southern Oregon University (SOU), the Job Council, and other training programs. | Regionally, there are few post-graduate degree opportunities, no research university, and no proactive regional programs to encourage college graduates to locate to the area. High school drop-outs have limited employability. | Advocate for training and programs that directly benefit Central Point employers. Support local schools to minimize high school drop-out rates. | High school drop outs have limited employability and demand disproportionate services. |
| Regulatory barriers | The Greater Bear Creek Valley Regional Problem-Solving Plan ("RPS") should encourage growth in the Tolo area and Central Point could capitalize on the advantages present. | The RPS may require additional planning work. | Capitalize on the opportunity for targeted employment growth in the Tolo area. | Delays in making the Tolo area market ready. |

Attachment: Economic Element (6/27/2019) (1163 : Economic Element)

vi. Competitive Position Summary

When all the regional and localized factors are synthesized, there appear to be at least four target industry sectors where the City of Central Point exhibits a strong and durable competitive position. These are the same industries identified in the 2013 Economic Element, and the conclusions in 2013 remain accurate in 2019.

- The specialty foods cluster that includes Lillie Belle Farms chocolates, Rogue Creamery, and the nearby Seven Oaks Farm just outside Central Point’s municipal boundary represents a small but unique opportunity for growth.
- Truck transportation and related support industries pay high wages to City residents and is a sector that both the Region and the City are well positioned to serve.
- Planned population growth in Central Point in the regional plan is expected to support expanded retail commercial within the City as the buying power of the City’s residential base expands.
- Planned population growth is also likely to support expanded healthcare services in the City. Overall, this sector is expected to grow rapidly within the region as exemplified by the Providence Medical Group building on Front Street. Although existing investments in Medford hospitals are likely to concentrate much of the regional growth, Central Point has an opportunity to keep pace with the growth in this sector.

Central Point also has some unique spatial characteristics that may support future economic activities in two other sectors due to the Greater Bear Creek Valley Regional Problem-Solving Plan (“RPS”). Specifically, there are aggregate employment uses and Erickson Air Crane that are located within the Tolo Urban Reserve Areas. These are both employer types with special needs, but the areas inclusion in the RPS Plan may present opportunities to work with these employers for mutual benefit.

vii. Assessment of Central Point’s Economic Development Potential

The DLCD’s Industrial & Other Employment Lands Analysis Guidebook recommends assessing the City’s economic potential based on several factors. *See Figure 24* for subjective scoring on each of Central Point’s competitive market advantages and disadvantages.

Central Point is located well in relation to markets and key transportation facilities. It is situated halfway between two major cities, Portland and San Francisco, is located on Interstate 5, and has ready access to the Rogue Valley International Airport. The drawbacks are that it is not located close to a major metro area and most flights from the airport require connecting flights at a major hub.

Central Point has excellent public facilities like water and sewer. There are rarely any service disruptions.

Central Point has fair access to labor markets. Its relative isolation from a major population center does increase costs and decreases its ready access. The same is true with materials and energy, aside from some natural resources like timber. But, as Section 5, Subsection iv demonstrates above, the Southern Oregon region is competitive in several labor markets.

Figure 24: Central Point's Economic Development Potential

| Description | Score |
|---|-----------|
| Location relative to markets | 3 |
| Availability of key transportation facilities | 3 |
| Key public facilities (water, sewer, etc.) | 4 |
| Labor Market (cost and access) | 2 |
| Materials and energy (availability and cost) | 2 |
| Necessary support services | 3 |
| Pollution control issues | 3 |
| Education and technical training | 2 |
| Other (such as land availability) | 3 |
| Total | 25 |

Scores: 1 = poor, 2 = fair, 3 = good, 4 = excellent

Central Point has good access to necessary support services. What businesses cannot get internally or in near-by Medford, they can get at a nearby major city like Portland, or probably find online.

Central Point has few pollution control issues, although the wildfire smoke in the summer months does harm to the local economy and industries like tourism.

The City has fair access to education and technical training. The area hosts both Rogue Community College (RCC) and Southern Oregon University (SOU). Other than that, most students must travel either to the Oregon Institute of Technology in nearby Klamath Falls, to a state school like the University of Oregon and Oregon State University in the Willamette Valley, or out of state altogether.

Lastly, Central Point has good access to other market advantages, such as a ready supply of land in the Rogue Valley and surrounding communities.

viii. Central Point's Projected Job Growth

Next, a forecast for Central Point's future job growth needs to be calculated. This is key to determining how much land is needed per industry category in Central Point through 2039. The following analysis is based on Central Point's population compared to the regional population. That population percentage is then applied to the regional job forecast.

For example, given that the population of Jackson County in 2018 was 219,270²⁰⁰ and the population of Josephine County is 87,487,²⁰¹ and Central Point has 19,101 people,²⁰² the City of Central Point currently has approximately 6.22 percent of the regional population. As a result, we can assume that Central Point will capture approximately 6.22 percent of jobs created regionally in the year 2019.²⁰³

By 2039, Central Point will grow by approximately 7,216 residents.²⁰⁴ This means that by 2039, Central Point will have approximately 7.06 percent of the regional population because Jackson County will have 264,951 people and Josephine County 107,470 people. *See Figure 25.* As a result, we can assume that Central Point will capture approximately 7.06 percent of jobs created regionally in the year 2039.²⁰⁵

But we need to know more than how many jobs are created in the year 2019 or in the year 2039—we need to know how many jobs will be created every year between 2019 and 2039 to get the total number of employment acres Central Point is going to need. Unfortunately, we only have the regional job data for those individual years, the regional and city population data, and what we have calculated to be Central Point's share of the region's job growth. However, if we take an average of Central Point's population share (that is, the average of 6.22 percent and 7.06 percent), we can estimate the average percentage of the regional population that Central Point will capture over the next 20 years, which is 6.64 percent. As a result, we can assume that Central Point will capture approximately 6.64 percent of the new jobs created regionally between 2019 and 2039.

Using the data in **Figure 25**, we can apply Central Point's projected population rates to forecast the number of jobs that Central Point will likely gain in each industry from 2019 to 2039. *See Figure 26* for the forecasted job numbers. Ultimately these numbers show that by 2039, Central

²⁰⁰ Portland State University, Population Research Center, *Jackson County Coordinated Population Forecast 2018 through 2068* 47 (June 30, 2018), available at: www.pdx.edu/prc/sites/www.pdx.edu/prc/files/Jackson_Report_Final.pdf (PDF warning).

²⁰¹ Portland State University, Population Research Center, *Josephine County Coordinated Population Forecast 2015 through 2065* 33 (June 2015), available at: www.pdx.edu/prc/sites/www.pdx.edu/prc/files/Josephine_Forecast_Report_201506.pdf (PDF warning).

²⁰² Portland State University, Population Research Center, *Jackson County Coordinated Population Forecast 2018 through 2068*.

²⁰³ Note that this assumes that Central Point has an equal percentage of the jobs created as compared to population, not that it has an equal percentage of total jobs now existing.

²⁰⁴ That is Central Point's forecasted 2039 population less the estimated 2018 population from **Figure 25** (26,317 – 19,101 = 7,216).

²⁰⁵ Note that this assumes that Central Point has an equal percentage of the jobs created as compared to population, not that it has an equal percentage of total jobs now existing.

Point will add 1,948 new jobs. This means that Central Point will need employment land to house these new workers.

Figure 25: Central Point's population growth rate

| City/County | Estimated 2019 | Estimated 2039 | Average Population Share, 2019-2039 ²¹⁵ |
|---|----------------|----------------|--|
| Central Point's Population ²¹⁷ | 19,101 | 26,317 | |
| Jackson County's Population ²¹⁶ | 219,270 | 264,951 | |
| Josephine County's Population ²¹⁸ | 86,423 | 97,377 | |
| Total Population of Both Counties | 305,693 | 362,328 | |
| Central Point's Capture Rate of Job Growth | 6.2% | 7.3% | 6.8% |

Source: 2019 PRC Coordinated Population Forecast, Jackson and Josephine Counties

Figure 26: Central Point's 20-year job forecast by industry

| Industry Sector | Southern Oregon's 20-Year Job Forecast ²⁰² | Central Point's Total Job Growth Capture at 6.8% of Regional Forecast (2039) |
|--|---|--|
| Construction & Natural Resources | 4,280 | 289 |
| Manufacturing | 1,900 | 128 |
| Transportation & Utilities | 660 | 45 |
| Wholesale Trade | 200 | 14 |
| Subtotal Industrial Jobs | 7,040 | 476 |
| Retail Trade | 1,960 | 132 |
| Financial | 640 | 43 |
| Services (professional, business, health, private education, hospitality, information) | 14,500 | 980 |
| Subtotal Commercial/Services Jobs | 17,100 | 1,155 |
| Institutional/Government | 1,640 | 111 |
| Other | 3,060 | 207 |
| Total New Jobs | 28,840 | 1,948 |

Based on the foregoing data, Central Point will need enough employment lands over the next 20 years for approximately 1,948 new jobs.

Section 6: Land Demand

Introduction This section projects the City of Central Point's short term (2019-2024) and long-term (2019-2039) supply of land needed to satisfy employment projections.

Having reviewed economic trends on a national, state, regional, and local level, it is important to use that information to identify economic development opportunities that are likely to expand or locate in or near Central Point within the next twenty years. Understanding the types of sites needed will enable the City to successfully implement its economic development objectives.

Legal Requirements Central Point must have adequate supplies of land to meet employment needs for a range of employment opportunities. These lands must be adequate to capitalize on the City's economic opportunities in terms of both quantity and type.

Central Point is required to identify the major categories of industrial or other employment uses that could reasonably be expected to locate or expand within the city's urban growth boundary. OAR 660-009-0015. A use or category of use will be reasonably expected to expand or locate to Central Point if it possesses the appropriate locational factors for the use or category of use.

Economic Growth Rate Forecast

It is expected that Central Point will at least maintain growth rates comparable to the region as a whole across all industries over the next twenty years and may reasonably be expected to exceed regional growth rates in target industries. Central Point's population is projected to grow at 1.5% through 2039, see **Figure 17** supra.

However, consistent with the City's competitive positions described above there are at least three sectors where the City is well positioned to capture additional economic opportunities and outperform the overall regional growth. Those sectors are specialty foods manufacturing, trucking and warehousing, and retail. It is in these three industry sectors that the State's regional forecast is appropriately adjusted upward to reflect localized opportunities (See Figure 27).

i. Specialty Food Manufacturing

This is a small but distinguished sector in the Central Point economy. Overall, modest growth assumptions in the manufacturing sector are likely to adequately capture growth potential in this niche sector but may buoy a slight edge over regional growth rates. However, exceptional growth in this sector is possible due to the exceptional quality of products in this niche. If such growth in the future materializes, then that may warrant a re-evaluation of the overall manufacturing employment growth forecast in the Economic Element.

ii. Trucking and Warehousing

The trucking and warehousing industry is strong regionally with higher than average employment concentrations. Median wages in the industry for Central Point residents are much

higher than regional or state averages. Assuring adequate supply of land for these uses represents an excellent opportunity to expand on an existing sector of strength that also pays relatively high wages. Also, this industry has potential interconnections with the wholesaling industry that creates the potential to outpace overall regional growth to a modest degree.

Central Point is also uniquely positioned to satisfy regional growth and capitalize on regional comparative advantages in this sector. The Greater Bear Creek Valley Regional Plan contemplates that the “Tolo” area is well situated for this type of economic activity north of Interchange 35 which already serves industrial traffic to White City and aggregate resource traffic in the area. There is very little residential and commercial development around the interchange. No new residential development is contemplated in the regional plan, so this area is well positioned to meet an important regional need for expanded transportation and warehousing uses.

However, the Tolo area is constrained because of a relative lack of water service. Any attempt to take advantage of this area would require a large investment to increase water and provide other necessary utilities.

iii. Retail

Retail represents another opportunity for the City of Central Point. Retail trade and associated employment tends to vary with population. From a retail trade perspective, population growth is essentially consumer growth. Thus, it is reasonable to expect that retail trade in Central Point will outpace the two-county regional rate and will keep pace with the annual average population growth as set out in the County’s coordinated population forecast for the City. From an industry categorization versus land use perspective there are some small but important differences. Land use terminology included within the retail category includes restaurants and bars while restaurants are categorized in the leisure and hostility industry sectors, so growth in this sector is appropriately consistent with the retail uses in both categorization schemes such as a boutique.

iv. Projected Growth Forecast by Industry

Figure 27 depicts a reasonable 10-year planned growth rate by industry for the City of Central Point. This growth rate utilizes the state’s regional forecast for all industries through 2027 and shows how much each industry is likely to grow both statewide and in the City of Central Point.

Figure 27: Central Point Projected Growth Rate by Industry²⁰⁶

| Industry Sector | State % Change, 2017-2027 | Central Point % Change, 2017-2027 |
|---|------------------------------|--------------------------------------|
| Total Private | 12.9% | 12.0% |
| Natural Resources and Mining | 11.1% | 23.0% |
| Construction | 17.5% | 25.0% |
| Manufacturing | 6.7% | 9.0% |
| Trade, Transportation & Utilities | 10.5% | 6.0% |
| Wholesale | 8.1% | 3.0% |
| Retail | 9.4% | 5.0% |
| Transportation, Warehousing & Utilities | 17.3% | 9.0% |
| Leisure and Hospitality | 13.1% | 13.0% |
| Professional & Business Services | 17.0% | 15.0% |
| Financial | 4.9% | 6.0% |
| Other Services | 10.6% | 10.0% |
| Information | 10.2% | 0.0% |

This is the best and most recent data available for regional industry growth projections over the mid-term (10 years). This economic element assumes that the rates will remain constant through 2039.

i. Site Requirements Analysis

Goal 9 requires an analysis of site requirements. The Economic Element and Buildable Land Inventory essentially breaks the City's employment land inventory by employment category. Within these general development pattern types, the Economic Element analyzes demand and supply of large, medium and small sites. In practice, there are no discrete size breaks that differentiate between large, medium and small sites, but it is useful to analyze different sizes because the site requirements do vary with firm size. **Figure 28** describes the qualitative site requirements for each of the general development pattern.

²⁰⁶ The data in the middle column is from the Gail Kiles Krumenauer, Senior Economic Analyst at the Oregon Employment Department, *Oregon Employment Industry Projections 2017-2027* (June 26, 2018), available at: www.qualityinfo.org/documents/10182/92203/Oregon+Industry+Employment+Projections+2017-2027?version=1.7 (Excel Warning). The data in the right column is from Guy Tauer, Regional Economist at the Oregon Employment Department, *Rogue Valley Industry Employment Projections 2017-2027*, available at: www.qualityinfo.org/documents/10182/92203/Rogue+Valley+Industry+Employment+Projections+2017-2027?version=1.5 (Excel Warning).

Figure 28: General Development Pattern Site Requirements

| Type | Public Facility and Service Requirements | Transportation Facility Requirements; Access to customers and workforce | Size Cat./ Typical Site Size (acres) | Discussion of Site Requirements by Size Category |
|-------------------|--|---|--------------------------------------|---|
| Retail Commercial | Retail commercial uses typically require all urban facilities and services such as water, sewer, storm drainage, police and fire protection, electricity, natural gas, and modern communications systems | Retail commercial development requires premium access and excellent visibility for customer attraction. Foot traffic and access to public transportation can also be important. | Large/ 8-30 | Large commercial sites tend to cluster within larger blocks of commercial that can be 100 acres or more. Outdoor storage sales can demand very large sites. These users will anchor commercial areas and attract customers for medium and small users. Must be located adjacent to and visible from major arterials and state highways. |
| | | | Med./ 2-7 | Medium commercial uses can locate within larger blocks of commercial or may function as a stand-alone community commercial use. Must be located adjacent to and visible from major arterials and collectors if not stat highways |
| | | | Small/ 0.5-2 | Small commercial uses fill in the spaces not used by medium and large retail commercial. These tend to be specialty sales that serve niche retail markets. |
| Office | Office uses typically require all urban facilities and services such as water, sewer, storm drainage, police and fire protection, electricity, natural gas, and modern communications systems | Consumer driven office users like branch banks & insurance sales must have good visibility and access. Other office uses only need reasonably direct access to the regional transportation network. Airport access can be essential | Large/ 3.5-12 | Large office uses will require excellent access to the regional transportation network because they have large workforces that require capacity in the system. Large office uses can locate in commercial or industrial areas depending on the specific requirements of the enterprise. |
| | | | Med./ 1-3.5 | Medium office uses that require customer significant access will seek out and compete for commercial zoned space. Other medium office uses may demand business park space intermixed with light industrial uses. |
| | | | Small/ 0.25-1 | Small office uses are the uses that “fill in” commercial and industrial areas because their needs are the most varied and requirements the most flexible |
| Industrial | Industrial uses may or may not require all urban services. However, many industrial uses will have very specific and large demands for certain services like power or sewage capacity | Access for freight is a top priority and may be via truck and/or rail. Industrial uses sometimes accept more remote locations to avoid congestion and that support freight movements. Airport access is often important. | Large/ 15-300 | Large industrial uses tend to conduct site searches on regional, national or internal scales. Factors that affect demand depends on the very specific requirements of the enterprise that are difficult to predict a priori. |
| | | | Med/ 3-14 | Medium industrial uses tend to be price sensitive and seek out space within business or office parks. They sometimes require property ownership that will also result in low real estate overhead in relation to the enterprise. |
| | | | Small/ 0.5-2.5 | Small industrial uses tend to be price sensitive. Low rent is a priority. Small site sizes can create challenges for freight movement to small industrial sites and also within the sites themselves. |

Attachment: Economic Element (6/27/2019) (1163 : Economic Element)

ii. Target Industries' Unique Site Requirements

In addition to the general development pattern site requirements, the site requirements specific to Central Point's target industries warrant more detailed consideration.

Specialty Food Products Manufacturing

The small cluster of businesses that are engaged in specialty food product manufacturing in Central Point have small retail storefronts that accompany their manufacturing businesses. The sites are generally small and there is limited room to expand operations on the existing sites. The segment of Highway 99 where these uses are located have good access to I-5. From there they have excellent visibility directly from Highway 99. However, the narrow strip between Highway 99 and the railroad tracks creates a practical/physical limit on future expansion. Central Point should keep lines of communication open with these businesses to assure that the site requirements for any expansion are well understood by staff and policy makers.

Truck Transportation and Transportation Support Services

These businesses require both office space and trucking facilities that are often co-located. Site requirements may also include space for related uses such as truck washes, truck driver accommodations and inter-modal freight handling. Large outdoor storage and warehouse space is typically required. Adequate expansion area is often a factor when selecting a site so that expansion can be accommodated without the need to relocate. Direct access to the interstate freeway is essential and must be located in areas that are relatively free from congestion to enable efficient freight movements. Aside from transportation facilities, power, and modern communications, some transportation uses may not necessarily require the full complement of other urban facilities and services.

Retail Trade

Convenient access to I-5 is important but meeting visibility site requirements from I-5 in Central Point is a challenge. The Pine Street interchange is somewhat congested and may raise site requirement concerns among larger retailers. Visibility from the Pine Street arterial is good and access can be made reasonably direct. Until an anchor center is sited that attracts regional shopping trips, the site requirements of many small and medium retailers cannot be met. The anchor tenants create a critical mass of shopping activity that then allows the small and medium retailers to achieve additional sales with shopping trips that are created by the anchor.

As the City's residential neighborhoods expand to the west and north there is a need for additional retail, and office, development to serve the particular commercial needs, both commercial and office, of the surrounding neighborhoods. The design and size of these commercial centers need to be based on the ultimate long-term density and area of the neighborhood and designed to complement the neighborhood's residential character. The location and design of these commercial centers need to support and encourage pedestrian access from the serving neighborhood. For land use planning purposes these centers are referred to as Pedestrian Oriented Neighborhood Commercial Centers.

Long-Term Land Demand Estimate

This section calculates Central Point’s land demand estimate for the next 20 years. **Figure 21** above provides the total number of jobs forecasted to be created in Southern Oregon through 2039. **Figure 25** calculates that Central Point should capture approximately 6.64 percent of these new jobs. **Figure 26** calculates that this equals approximately 1,915 new jobs for Central Point and allocates them by industry.

Employment land demand estimates can be projected using a variety of techniques, but this Economic Element calculates the land needs by converting the projected population growth rates into projected employees and then using average employee space needs and floor area ratios to project future land needs. See **Figure 32** for the estimate of employee density per acre. Then these land needs are aggregated by the development pattern type demanded by each industry so that the demand projections can ultimately be reconciled with land base supply calculations. Each of these steps requires assumptions about expected ratios and land development efficiencies.

iii. Estimate of Needed Employment Lands

In order to estimate the number of acres needed by 2039 for all Central Point’s industries, this section uses an employee per acre ratio. According to the DLCDC’s Industrial & Other Employment Lands Analysis Guidebook, there are typically 8-12 industrial sector jobs per acre, 14-20 commercial and service sector jobs per acre, 6-10 institutional and government jobs per acre, and 6-10 other employment sector jobs per acre.²⁰⁷

Figure 29: Projected Employment Net Buildable Land Needed 2019 to 2039

| | Land Use Classification | Number of Jobs ²²⁴ | Jobs/Buildable Acre Ratio from DLCDC ²²⁵ | Employment Buildable Acres Needed ²²⁶ | Existing Buildable Acre ²²⁷ | Buildable Acreage Surplus/Shortage |
|----------------------------------|-----------------------------------|-------------------------------|---|--|--|------------------------------------|
| 2017 Jobs ²²⁸ | Industrial | 1,658 | 8 | | | |
| | Commercial/Service | 4,407 | 14 | | | |
| | Institutional/Gov't | 892 | 6 | | | |
| | Other Services & Self-Employment | 740 | 6 | | | |
| | Total | 7,697 | 22 | - | - | - |
| | Jobs Added by 2039 ²²⁹ | Industrial | 476 | 8 | 59 | 87 |
| Commercial/Service | | 1,155 | 14 | 83 | 61 | (21) |
| Institutional/Gov't | | 111 | 6 | 18 | - | (18) |
| Other Services & Self-Employment | | 207 | 6 | 34 | - | (34) |
| Total | | 1,948 | | 142 | 148 | (47) |

Note: Employment Gross Acres Needed calculated using Buildable Acres adjusted for right-of-way (25%)

Figure 30 takes the number of jobs Central Point expects to gain by 2039 and estimates how many acres are needed for each major employment land use type based on the DLCDC’s employee per acre ratio. Then, it compares that to the total net buildable acres currently in the City. As a result, Central Point will need 47 new net acres in the aggregate by 2039.

However, Central Point will have a slight surplus of industrial lands but a deficit of commercial, institutional, and other land types. To eliminate this deficit, Central Point will need to add

²⁰⁷ DLCDC’s *Industrial & Other Employment Lands Analysis Guidebook*, 2-46.

approximately 73 gross acres of commercial, institutional, and other land types of lands by 2039.²⁰⁸ See **Figure 30**.

Figure 30: Gross Acres Needed²⁰⁹

| Sector | New Buildable Acres Needed by 2039 | Gross Employment | |
|----------------------------|--|-----------------------------|---|
| | | Acres Needed, 2019- 2039 | Short-Term Gross Acres Needed, 2019-2024 |
| Industrial | - | - | - |
| Commercial/Service | 21 | 27 | 7 |
| Institutional/Government | 18 | 23 | 6 |
| Other/Uncovered Employment | 34 | 43 | 11 |
| Total Employment | 74 | 93 | 23 |

Another way to estimate the land demand is to compare the above result to the conclusions reached in other parts of the Central Point Comprehensive Plan. For example, Central Point's *Economic Element 2013-2033* found that the City would need between 59 and 67 acres by 2033. See also Central Point's *Land Use Element 2018-2038*, which made the same findings.

The previous Economic Element estimated that Central Point needs approximately 13 acres of employment lands per 1,000 residents.²¹⁰ Currently, Central Point has approximately 19,101 people²¹¹ and the 2039 population is projected to be around 26,317.²¹² This increase of approximately 7,216 residents means that Central Point would need a total of 93.8 additional acres for employment purposes in the long-term.²¹³ But, because there is a surplus of approximately 23 Industrial site acres, Central Point actually needs 65 acres.²¹⁴

Conclusion In conclusion, based on Central Point's projected job capture rate, the Comprehensive Plan's previous calculations, and the estimated ratio of residents to land use needs, Central Point has a forecasted demand of 65 to 74 additional net acres for employment purposes for the 2019 to 2039 planning period.

Short-Term Land Demand Estimate

By quartering the numbers from the long-term estimate, the short-term land employment use needs can be determined. As a result, Central Point will need 18 additional net acres for the next five years (2019-2024). See **Figure 30**.

Inventory of Employment Lands

After identifying economic opportunities and estimating land demand, the next step in the Goal 9

²⁰⁸ That is, $(21.1714) + (18.1667) + (33.8333) = (73.1714)$.

²⁰⁹ See **Figure 29**. Rounded to the nearest tenth.

²¹⁰ Central Point Land Use Element 2018 at 27.

²¹¹ *Id.* at 9.

²¹² Population Research Center, Portland State University, *Jackson County Final Forecast Report*, Cycle 2: Region 47 Documents (May 2018).

²¹³ That is, $((26,707 - 19,101) / 1000) * 13$ acres

²¹⁴ That is, 93.8 acres – 28.395.

process is to evaluate the current land base and its ability to meet the site needs for which there is a projected demand over the next twenty years. Central Point updates its general buildable lands information on a regular basis and this information has been used as the starting point to analyze the land base from a more specific Goal 9 perspective.

The Central Point *Buildable Lands Inventory (BLI): 2019-2039* has been published by the City of Central Point as a separate document. The above-conclusion that Central Point needs 65 to 73 additional net acres by 2039 considers the findings of the BLI, including that there is a slight surplus of industrial lands.

i. Redevelopment and Land Use Efficiency

The City of Central Point's current built employment land base has relatively limited redevelopment potential. According to the BLI, the City only has 8.95 acres of total commercial lands and 36.18 acres of industrial lands that are redevelopable.²¹⁵ This configuration does not lend itself well to redevelopment on a scale that would significantly alter the supply and demand for sites over a twenty-year period because this would require the demolition and aggregation of parcels. While this type of redevelopment does occur on occasion, it is unlikely to be economically viable in Central Point on a scale that would alter long-term supply and demand projections for employment lands. This quantitative determination does not mean that there are not good qualitative reasons to support redevelopment, especially in the downtown and along Highway 99.

There exists a small amount of redevelopment potential along Table Rock Road.²¹⁶ Several parcels are zoned residential and that are large enough to be developed for employment uses. Other parcels are not intensively developed. However, this is an area where relatively inexpensive small industrial sites are available to own and where there are limited development requirements that add overhead. In some ways, this area is important employment land for certain types of firms that have ever fewer places to locate in the valley in a manner that is cost-effective. As such, aggressive redevelopment planning policies for this area may seem to be a great aesthetic endeavor but may have adverse and unintended economic consequences. Moreover, without relatively massive financial incentives for significant redevelopment that would change the overall quality of development in this area, lesser redevelopment policies tend to have the opposite effect where owners intentionally avoid development projects that would trigger expensive design and aesthetic upgrades to their respective properties.

ii. Vacant Lands

According to the BLI, most of the City's vacant acreage consists of Medium Industrial lands, as well as Large and Medium Retail.²¹⁷ The City has barely any vacant acreage allocated predominantly to office use of any kind. It also has little acreage dedicated to small retail. However, according the analysis in this Economic Element, Central Point's economy will likely

²¹⁵ Central Point *Buildable Lands Inventory (BLI): 2019-2039* at 6, Tables 3 and 4.

²¹⁶ See Central Point *Buildable Lands Inventory (BLI): 2019-2039* at 13.

²¹⁷ *Id.* at 7, Figure 3.

have its strongest growth in industries that require retail and office space. As a result, the City needs to increase its buildable lands in these categories.

Further, according to the BLI, most of the vacant number of lots are in small retail (even though there is little total acreage).²¹⁸ Further, there are few vacant lots of any kind for offices, large retail, and large industrial.²¹⁹ As a result, the City will need more parcels for offices of every size and for large industrial and large retail.

Another consideration in the employment land demand and current employment land inventory is the spatial relationship between existing inventory and future demand. As the City's residential neighborhoods (UGB) expand to the west and north additional employment lands will be needed for Pedestrian Oriented Neighborhood Commercial Centers. As would be expected the City's current employment land inventory (planned and zoned) is not spatially appropriate for these new expanding neighborhoods, and in terms of inventory are considered excess supply. Consequently, there will be a need to discount some of these lands when addressing the supply need for new Pedestrian Oriented Neighborhood Commercial Centers.

iii. Conclusion

A stable and diverse economy that provides access to employment opportunities for Central Point's growing population is fundamental to providing a livable community consistent with the City's vision and preferred future. Based on the analysis herein, the City will experience growth across all employment categories and is particularly well positioned to experience growth in specialty foods, trucking and transportation, healthcare and retail services. However, proactive and effective strategies will be necessary to attract, retain and expand a diverse business environment to provide for the City's employment needs as they change over time. To accomplish this, the City recognizes the following considerations as essential to fostering an effective economic development program in Central Point:

1. Collaboration, Partnership & Comparative Advantages Must Be Leveraged. Effective economic development actions necessary to diversify the City's economic base requires an understanding of, and a careful balance between regional cooperation and competition. It is important to understand and pro-actively participate in the broader national, state, and regional economic development discussions. Participating in regional economic development programs like Southern Oregon Regional Development, Inc. (SOREDI) and the Rogue Valley Workforce Development Council can improve the regional economic climate and a strong regional economy will benefit all communities within the region. Most importantly, to be an effective participant the City must recognize its competitive advantage within the region and compete for those economic development opportunities within the region for which Central Point is well positioned.
2. Adequate Land Supply and Development Site Characteristics Needed to be Competitive: The City will need to provide adequate land supply in terms of both acreage and development site characteristics to effectively respond to business development needs.

²¹⁸ *Id.*

²¹⁹ *Id.*

This need is particularly true for Neighborhood Commercial lands as the City expands its urban growth boundary. At this time, the City does not have enough employment lands to meet the projected economic needs over the next 20 years. Population growth and job forecasts indicate that the City will need more lands for Office, Retail and Institutional employment uses with a focus on development sites suitable for medium and large office and retail uses and availability of vacant buildings for expanding small businesses (i.e. flex-space). Over the 2019-2039 planning period, the City will need to expand the UGB to ensure an adequate 5-year and 20-year supply of buildable employment land (Table 30).

3. Dynamic Economic Conditions Require Proactive and Responsive Management. The economy is dynamic and even economic opportunities for which the City is well positioned require timely and concerted action. These dynamic economic forces require the City to be responsive and flexible to capitalize on opportunities as they arise. They also require the City to engage in sustained analysis of national, state, and local economic conditions. Only when the City is actively monitoring its economy will it be poised to take advantage of good opportunities and guide the community through any turbulent times.

Furthermore, the pursuit of beneficial economic development requires a balance between short-term and long-term economic objectives. The City recognizes that some opportunities may warrant short-term incentives to achieve longer term employment or property tax revenue objectives; while other opportunities may have a lesser long-term benefit and may not warrant the short-term fiscal cost of incentives.

Section 7: Goals and Policies

Statewide Planning Goal 9 requires that comprehensive plans and policies contribute to a stable and healthy economy in all regions of the state. This section sets forth the City of Central Point's economic development goals and policies.

Goal 1 To actively promote a strong, diversified, and sustainable local economy, that reinforces Central Point's "small town feel"²²⁰ and family orientation while preserving or enhancing the quality of life in the community as a place to live, work, and play.

Because this Economic Element concludes that there will be economic uncertainty in the short-term, it is important that Central Point work to diversify and strengthen its economy. By continuing to analyze economic trends, Central Point will be able to continue growing strong throughout the 2019-2039 planning period.

Goal 2 To create meaningful incentives to encourage and support economic development;

Central Point has historically been a bedroom community where people live but work elsewhere. In order to maintain a strong tax base and to ensure continued economic prosperity, Central Point must take an active role in encouraging economic development.

Goal 3 To encourage and promote the development, redevelopment, and enhancement of retail and office areas to achieve a vibrant shopping, entertainment, living and working experience in the downtown area.

This goal is important because Central Point needs a vibrant downtown in order to ensure future economic prosperity. Further, based on the current BLI and the projected land use needs, Central Point is going to need targeted redevelopment strategies to encourage these types of activities in the future.

Goal 4 To encourage active communication and cooperation between the City, local, and state agencies, and local businesses concerning economic development, education, and workforce development.

The City cannot reach its goals without the assistance of others. As a result, the City needs to be receptive to suggestions and aid from others and also needs to be active in communicating its needs and plans.

Goal 5 To encourage and support growth, particularly in the targeted industries (specialty food manufacturing, and trucking and warehousing sectors).

²²⁰ As defined in the Urbanization Element of the Comprehensive Plan

These targeted industries are where the City could make strides. It is important that the City help maintain and grow these industries now and in the future.

Goal 6 To maintain at all times an adequate supply of suitable short-term (five-year) employment lands.

Central Point does not have an adequate short-term supply of lands for institutional/government and other employment types. As a result, the City should plan to add to the land supply in the near future.

Goal 7 To prepare and maintain a City of Central Point Economic Development Manual identifying and monitoring economic development strategies and programs available to the City.

Goal 8 Create a positive environment for industrial, commercial and institutional job growth and development by maintaining an adequate land supply; providing a local development review process that is predictable, responsive, and efficient; and delivering high quality public facilities and services.

Goal 9 *Assure, through the UGB process, that adequate commercial lands are planned and designated for the development of pedestrian oriented neighborhood commercial centers to serve the City's new residential neighborhoods.*

The City's economic development goals will be managed through the following policies:

Policy 1: Participation

The City shall participate on the regional and state level in the development and programming of alternative financial incentives and initiatives for economic development, including education and workforce development that are consistent with the City's economic development goals.

Policy 2: Refine Policies

The City shall continue to monitor and refine its land development and fiscal policies as they relate to economic development to ensure that the City's economic development programming can be effectively implemented.

Policy 3: Monitor Long-Term Consequences

Consider economic development incentives as an inducement to development only when it can be demonstrated that the short-term consequences are understood and found to be acceptable and the long-term consequences are determined to be beneficial to the City.

Policy 4: Small Businesses

The City shall pursue and encourage development of leasable employment buildings (i.e. flex-space) to create opportunities to expand, retain and attract small businesses to Central Point's employment districts.

Policy 5: Business Innovation

Encourage innovation, research, development, and commercialization of new technologies, products, and services through responsive regulations and public sector approaches.

Policy 6: Tolo Area

The City shall, in collaboration with Jackson County, continue planning the Exit 35 area—also called “Area CP-1B (Tolo)”—in the Regional Plan Element, to capitalize on economic opportunities, especially for transportation-based economic activity and truck/rail freight support services. This area also contains the aeronautics manufacturing company Erickson Air Crane and serves aggregate uses; these uses have many specific and unique dimensions that should be carefully considered. Plans and land use regulations applicable to this area need to account for the site requirements of firms in these sectors. Because the area is currently constrained as a result of a lack of access to water, the City should begin planning how to make water more readily available so as to make these lands available for more economic development.

Policy 7: Monitor Regulations

The City shall periodically evaluate its regulations for employment related development, particularly as it relates to targeted industries, as well as compatibility with adjacent non-employment lands to ensure that regulations are consistent with applicable best practices. Regulations found to no longer be appropriate should be amended as soon as practicable thereafter.

Policy 8: Adequate Short-Term Supply

The City shall assure that, through its Capital Improvement Program, public facilities and transportation facilities are available and adequate in capacity to maintain a supply of competitive short-term buildable lands sufficient to meet employment needs within a five-year period, particularly for the retail, specialty foods, professional, health care, and trucking sectors.

Policy 9: Prepare for Long-Term Needs

The City shall maintain a supply of competitive short-term employment lands in the medium and large site categories equivalent to the twenty-year demand for those categories. The supply of short-term employment land shall be reviewed and updated every four years consistent with the Portland State University Population Research Center Coordinated Population Forecasting schedule. When it is determined that the supply of land as measured in terms of number of sites and/or acreage in the medium and large site categories is inadequate to serve the twenty-year

needs then the City shall amend its UGB to include additional short-term (5-year) employment lands.

Policy 10: Pedestrian Oriented Neighborhood Commercial Centers.

As the City's expands the UGB it will include in the land use mix adequate commercial lands to for the development of Pedestrian Oriented Commercial Centers designed to compliment the physical character and encourage neighborhood pedestrian use. Adequacy of the acreage needed for Pedestrian Oriented Commercial Centers will be guided by the Regional Plan land use allocation.



City of Central Point **Staff Report to Council**

ISSUE SUMMARY

| | | | |
|-------------------------|--|------------------------|--------------|
| TO: | City Council | DEPARTMENT: | City Manager |
| FROM: | Chris Clayton, City Manager | | |
| MEETING DATE: | June 27, 2019 | | |
| SUBJECT: | Resolution No. _____, Approving the Award of a Contract for the City Council Chambers Renovation Project | | |
| ACTION REQUIRED: | Resolution | RECOMMENDATION: | Approval |

BACKGROUND INFORMATION:

Over the past 12 months, city staff has planned, designed, and budgeted for the upgrade of the City's Council Chambers facility. Based on an intermediate procurement process conducted earlier this year, city staff is recommending the City Council Chambers Renovation Project be awarded to Outlier Construction, LLC. in the amount of 149,006.00

FINANCIAL ANALYSIS:

The 2019-2021 City of Central Point Reserve Fund – Facilities Improvements includes the following:

City Hall Improvements: \$365,000.

The City Council Chambers Renovation Project's specific budget appropriation is \$150,000. Given the nature of this project, city staff feels there is a low risk of project cost overruns.

LEGAL ANALYSIS:

Central Point Municipal Code (CPMC)

2.40.040 Public contracts--Model rules.

The model rules adopted by the attorney general under ORS 279A.065 (Model Rules) are adopted as the public contracting rules for the city of Central Point, to the extent that the model rules do not conflict with the provisions of this chapter or any public contracting rules adopted by resolution of the council. (Ord. 1963 §2, 2012; Ord. 1872 (part), 2006).

2.40.050 Public contracts--Authority of purchasing agent.

- A. General Authority. The city manager shall be the purchasing agent for the city of Central Point and is hereby authorized to issue all solicitations and to award all city of Central Point contracts for which the contract price does not exceed one hundred fifty thousand dollars. Subject to the provisions of this chapter, the purchasing agent may adopt and amend all solicitation materials, contracts and forms required or permitted to be adopted by contracting agencies under the Oregon Public Contracting Code or otherwise convenient for the city of Central Point's contracting needs. The purchasing agent shall hear all solicitation and award protests.
- B. Delegation of Purchasing Agent's Authority. Any of the responsibilities or authorities of the purchasing agent under this chapter may be delegated and subdelegated by written directive.
- C. Mandatory Review of Rules. Whenever the Oregon State Legislative Assembly enacts laws that cause the attorney general to modify its model rules, the purchasing agent shall review the public contracting rules, other than the model rules, and recommend to the city council any modifications required to ensure compliance with statutory changes. (Ord. 1963 §3, 2012; Ord. 1872 (part), 2006).

Oregon Revised Statutes Chapter 279

279B.070 Intermediate procurements. (1) A contracting agency may award a procurement of goods or services that exceeds \$10,000 but does not exceed \$150,000 in accordance with intermediate procurement procedures. A contract awarded under this section may be amended to exceed \$150,000 only in accordance with rules adopted under ORS 279A.065.

(2) A contracting agency may not artificially divide or fragment a procurement so as to constitute an intermediate procurement under this section.

(3) When conducting an intermediate procurement, a contracting agency shall seek at least three informally solicited competitive price quotes or competitive proposals from prospective contractors. The contracting agency shall keep a written record of the sources of the quotes or proposals received. If three quotes or proposals are not reasonably available, fewer will suffice, but the contracting agency shall make a written record of the effort the contracting agency makes to obtain the quotes or proposals.

(4) If a contracting agency awards a contract, the contracting agency shall award the contract to the offeror whose quote or proposal will best serve the interests of the contracting agency, taking into account price as well as considerations including, but not limited to, experience, expertise, product functionality, suitability for a particular purpose and contractor responsibility under ORS 279B.110. [2003 c.794 §54; 2013 c.66 §2]

COUNCIL GOALS/STRATEGIC PLAN ANALYSIS:

2019-2021 Adopted Council-Administration Goal:

Facilities Modernization

2019-2021 Budget Facilities Maintenance Objective:

Improve facilities to ensure that the community and employees have safe, efficient, clean, and

contemporary city facilities.

STAFF RECOMMENDATION:

Staff recommends approval of a resolution authorizing the city manager to execute a contract with Outlier Construction, LLC. for the improvement related to the City Council Chambers Renovation Project.

RECOMMENDED MOTION:

I move to approve resolution number _____ authorizing the city manager to execute a contract with Outlier Construction, LLC. for the City Council Chambers Renovation Project in the amount of \$149,006.00

ATTACHMENTS:

1. Invitation to Bid
2. Outlier Bidder Certificate
3. Construction Drawings
4. Council Chambers Renovation Contract
5. Council Chambers Renovation Resolution



Invitation to Bid For Public Improvement

(Contract with subcontractor contract value equal to or greater than 5% of total bid or bid over \$15,000)

City Administration

CONTRACT NO.: **CP-19-001** PUBLISHED: **04/05/2019 (revised 4/23/2019)**
DESCRIPTION: **Central Point Council Chambers Renovation**
BUYER: **City of Central Point**
CONTACT PERSON: **Derek Zwagerman**
PHONE: 541-423-1024 FAX: 541-664-1611 E-MAIL: derek.zwagerman@centralpointoregon.gov

PRE-BID CONFERENCE: **No**

~~PRE QUALIFICATION CLASS REQUIREMENTS: (All persons, individuals, firms, corporations or partnerships intending to submit proposals shall submit qualification statements at least ten (10) days prior to the Opening of Bids.)~~

SCOPE OF PROJECT: Remodel of Central Point Council Chambers

SEALED Bids will be received until the Bid Close date, time, and place stated below:

CLOSE DATE: The date and time after which Bids will not be received.

BID CLOSE DATE: **05/15/2019**

BID CLOSE TIME: **02:00** Pacific Time

BID OPENING IS THE SAME AS BID CLOSE DATE.

PLACE: **City of Central Point
Building Department
140 S. Third St.
Central Point, OR 97502**

Pursuant to ORS 279C.370, for contracts over one hundred thousand dollars (\$100,000), all Bidders shall submit to Contact Person within two (2) working hours after the above BID CLOSE DEADLINE a disclosure of any first-tier subcontractor intended to furnish labor or materials in connection with the Public Improvement Bid. Such disclosure shall be disclosed in the form provided. (Bid Document IV-First-Tier Subcontractor Disclosure Form)

All Bids received which are in proper form will be opened publicly by the contracting agency immediately after the deadline for submission of Bids. At that time, the City may take various actions including, but not limited to, selecting the winning Bid, rejecting all Bids, or postponing any such action for a period not to exceed two (2) weeks from the opening, during which period the Bids will be irrevocable. The City of Central Point may reject any Bid noncompliant with any prescribed public Bidding procedure(s) and/or requirement(s), and, in its sole discretion, may reject for good cause any or all Bids upon the City of Central Point finding that it is in the public interest.

Any questions or issues regarding specifications, Bidding process, and/or award process shall be directed only to Contact Person designated above.

All Bids are subject to the ordinances, rules, and regulations of the City of Central Point and ORS 70, ORS 279, 279A-279C and related model rules may be used for guidance, but not for mandatory direction.

TABLE OF CONTENTS

"X" INDICATES MANDATORY PAGES TO BE COMPLETED AND RETURNED WITH BID RESPONSE

Bid Documents

| | PAGE |
|---|-----------|
| I. INSTRUCTIONS TO BIDDERS..... | 3 |
| II. BIDDER INSURANCE REQUIREMENTS | 9 |
| III. BIDDER CERTIFICATE..... | X..... 11 |

Attachment: Invitation to Bid (1157 : City Council Chambers Renovation Project Contract Approval)

IV. FIRST-TIER SUBCONTRACTOR DISCLOSURE FORM 14
 V. SUBCONTRACTORS LISTX..... 16
 VI. ENVIRONMENTAL AND NATURAL RISK DISCLOSURE FORMX..... 18
 VII. BID BOND.....X..... 19
 VIII. BIDDER'S PROPOSAL.....X.....20

ATTACHMENTS: The following will be part of any resulting Bid Award and are hereby incorporated by reference:

PERFORMANCE AND LABOR AND MATERIAL PAYMENT BOND 22
 CONSTRUCTION CONTRACT24
 STANDARD GENERAL CONDITIONS26
 DOCUMENT SUBSTITUTION REQUEST FORM48
 SUBSTITUTION LIST.....50
 SPECIAL PROVISIONS..... Provided by Department
 SUPPLEMENTAL STANDARD SPECIFICATIONS; Provided by Department

Attachment: Invitation to Bid (1157 : City Council Chambers Renovation Project Contract Approval)

III. BIDDER CERTIFICATE

THIS CERTIFICATION MUST BE COMPLETED, SIGNED AND RETURNED. FAILURE TO DO SO WILL RESULT IN BID DISQUALIFICATION.

RESIDENCY INFORMATION [ORS 279C.365(h)].

ORS 279A.120(2) states "For purposes of awarding a public contract, a contracting agency shall: . . . (b) Add a percent increase to the bid of a nonresident bidder equal to the percent, if any, of the preference given to the bidder in the state in which the bidder resides."

"Resident bidder" means a bidder that has paid unemployment taxes or income taxes in this state during the twelve(12) calendar months immediately preceding submission of the bid, has a business address in this state and has stated in the bid whether the bidder is a "resident bidder" [ORS 279A.120(b)].

"Non-resident bidder" mean's, a Bidder who is not a "resident bidder" as defined above [ORS 279A.120(1)(a)].

a. CHECK ONE: Bidder is a RESIDENT Bidder [] NON-RESIDENT Bidder.

b. If Resident Bidder, enter your Oregon business address:

841 O'HARE PARKWAY STE. 100 MEDFORD, OR 97504
(Physical address)

841 O'HARE PARKWAY STE. 100 MEDFORD, OR 97504
(Mailing address)

c. If a Non-Resident Bidder, enter state of residency: _____

d. If a Non-Resident Bidder, do you or your firm receive, or are you or your firm eligible for, any preference in award of contracts with your state's government or with other governmental bodies in your state?

CHECK ONE: [] YES [] NO

If yes, state the preference percentage: _____ %

If yes, but not a percentage of Bid price, describe the preference:

If yes, state the law or regulation that allows the preference described (legal citation):

CONSTRUCTION CONTRACTORS BOARD

Bidders shall be registered with the Construction Contractors Board, 700 Summer Street NE, Suite 300, Salem, Oregon 97301, telephone (503) 378-4621. Bidders Construction Contractors Board registration number is:

CONSTRUCTION CONTRACTORS BOARD REGISTRATION NO. 217660

Attachment: Outlier Bidder Certificate (1157 : City Council Chambers Renovation Project Contract Approval)

COMPLIANCE WITH OREGON TAX LAWS

For purposes of this certificate, 'Oregon Tax Laws' means those programs listed in ORS 305.380(4) which is incorporated herein by this reference. Examples include the state inheritance tax, personal income tax, withholding tax, corporation income and excise taxes, amusement device tax, timber taxes, cigarette tax, other tobacco tax, 9-1-1 emergency communications tax, the homeowners and renters property tax relief program and local taxes administered by the Department of Revenue (Lane Transit District Employer Payroll Tax, The County Metropolitan Transit District of Oregon "Tri-Met" Employer Payroll Tax, and Tri-Met Self-Employment Tax).

CHECK ONE: Bidder states that it **Does** **Does not** have authority and knowledge regarding the payment of taxes, and that Contractor is, to the best of its knowledge, not in violation of any Oregon tax laws.

NON-DISCRIMINATION INFORMATION

ORS 279A.110(1) states: "A bidder . . . may not discriminate against a subcontractor in the awarding of a subcontract because the subcontractor is a minority, women or emerging small business enterprise certified under ORS 200.055 . . . (4) A bidder . . . shall certify . . . that the bidder . . . has not discriminated and will not discriminate, in violation of subsection (1) . . ."

CHECK ONE: Bidder states that it **Has** **Has not discriminated and will not discriminate** against minority, women or emerging small business enterprises in obtaining any required subcontracts.

PREVAILING WAGE INFORMATION

ORS 279C.365(g) states in substance: "that no bid will be received or considered by the contracting agency unless the bid contains a statement by the bidder that bidder will comply with ORS 279C.840 (Prevailing Wage Rates) or the Davis-Bacon Act (40 U.S.C. 276a)."

CHECK ONE: Bidder states that it **Will** **Will not** comply with ORS 279C.840 or 40 U.S.C. 276a.

DRUG-TESTING PROGRAM

ORS 279C.505(2) requires that all public improvement contracts require contractors to demonstrate that it has an employee drug-testing program in place that applies to all employees, and will maintain a drug testing program at all times during the performance of the Contract awarded. Failure to maintain a program shall constitute a material breach of contract.

CHECK ONE: Bidder states that the Bidder **Does** **Does Not** comply with ORS 279C.505(2).

ASBESTOS ABATEMENT LICENSE

ORS 279B.055(2)(g) requires the contracting agency to issue an Invitation to Bid that requires the contractor or subcontractor to possess an asbestos abatement license, if required under ORS 468A.710.

CHECK ONE: Bidder states that the Bidder **Does** **Does Not** possess an asbestos abatement license.

Attachment: Outlier Bidder Certificate (1157 : City Council Chambers Renovation Project Contract Approval)

I, the undersigned, a duly-authorized representative of the Bidder, hereby certify that the answers to the foregoing BIDDER CERTIFICATE questions and all statements therein contained are true and correct.

Signature: RM Date 5/15/19
Printed Name ROBB MAYERS Title CEO
Firm OUTLIER CONSTRUCTION LLC Telephone 541-622-2040

Attachment: Outlier Bidder Certificate (1157 : City Council Chambers Renovation Project Contract Approval)

V. SUBCONTRACTORS LIST

(Submit this form with Bid. It is an integral part of the Bid.)

CONTRACT NO: N/A
 PROJECT: CENTRAL POINT COUNCIL CHAMBERS RENOVATION

BIDDER: OUTLIER CONSTRUCTION LLC
 DATED: 5/15/19

The following work will be performed or provided by Subcontractors and coordinated by us:

| ITEM OF WORK | SUBCONTRACTOR / SUPPLIER | TELEPHONE / FAX |
|----------------------------|---------------------------|----------------------------------|
| SITWORK | N/A | |
| LANDSCAPE & IRRIGATION | N/A | |
| PAVING | N/A | |
| CONCRETE | N/A | |
| STRUCTURAL STEEL | N/A | |
| WOOD FRAMING | N/A | |
| CASEWORK / TRIM | NEW HORIZONS WOODWORKS | 541-482-0653 P 541-482-7578 F |
| SHINGLE ROOFING | N/A | |
| DOORS/FRAMES/HARDWARE | N/A | |
| GYPSUM BOARD/ACOUSTIC TILE | N/A | |
| CARPET/VINYL | CT COMMERCIAL | 541-776-3221 P 541-842-4307 F |
| PAINTING | RLI | 541-973-5623 P |

Attachment: Outlier Bidder Certificate (1157 : City Council Chambers Renovation Project Contract Approval)

| | | |
|------------|-----|--|
| PLUMBING | N/A | |
| ELECTRICAL | N/A | |
| HVAC | N/A | |
| | | |
| | | |

(LIST ANY ADDITIONAL CATEGORIES. USE CONTINUATION SHEET IF NECESSARY).

VI. ENVIRONMENTAL AND NATURAL RISK DISCLOSURE FORM

DATE: 5/15/19

CONTRACT NO: N/A

PROJECT: CENTRAL POINT COUNCIL CHAMBERS RENOVATION

BID DEADLINE: 05/15/2019, 02:00 PM Pacific time

NAME OF BIDDING CONTRACTOR: OUTLIER CONSTRUCTION LLC

As permitted by ORS 279C.525(8)(a), the City of Central Point shall allocate all or a portion of the known environmental and natural resource risks to the Contractor. The following disclosure is a specific listing of such environmental and natural resource risks of which Bidder has made diligent inquiry and is aware that pertains to the above referenced project.

1. Environmental or Natural Resource risk

2. Environmental or Natural Resource risk

3. Environmental or Natural Resource risk

(Attach additional sheets as necessary)

Attachment: Outlier Bidder Certificate (1157 : City Council Chambers Renovation Project Contract Approval)

VII. BID BOND

We, Outlier Construction, LLC, as "Principal,"

(Name of Principal)

and Travelers Casualty and Surety Company of America, a CT Corporation,

(Name of Surety)

authorized to transact Surety business in Oregon, as "Surety," hereby jointly and severally bind ourselves, our respective heirs, executors, administrators, successors and assigns to pay unto the City of Central Point ("Obligee") the sum of (\$ 5%)

Five Percent of Amount Bid dollars.
(Write dollar figure)

WHEREAS, the condition of the obligation of this bond is that Principal has submitted its proposal or Bid to an agency of the Obligee in response to Obligee's procurement document (No. 1810) for the project identified as:

Central Point Council Chambers Renovation which proposal or Bid is made a part of this bond by reference, and Principal is required to furnish Bid security in an amount equal to five (5%) percent of the total amount of the Bid pursuant to ORS 279.C365(5) and the procurement document.

NOW, THEREFORE, if the proposal or Bid submitted by Principal is accepted, and if a contract pursuant to the proposal or Bid is awarded to Principal, and if Principal enters into and executes such contract within the time specified in the procurement document and executes and delivers to Obligee its good and sufficient performance and payment bonds required by Obligee within the time fixed by Obligee, then this obligation shall be void; otherwise, it shall remain in full force and effect.

IN WITNESS WHEREOF, we have caused this instrument to be executed and sealed by our duly authorized legal representatives this 10th day of May, 2019.

PRINCIPAL: Outlier Construction, LLC

SURETY: Travelers Casualty and Surety Company of America

By [Signature]
Signature

BY ATTORNEY-IN-FACT:

CEO
Official Capacity

Cynthia L. Heiney
Name

Attest: [Signature]
Corporation Secretary

[Signature]
Signature

960 Broadway Avenue, Suite 500
Address

Boise City ID State 83706 Zip

208-383-6861 Phone _____ Fax

Attachment: Outlier Bidder Certificate (1157 : City Council Chambers Renovation Project Contract Approval)

VIII. BIDDER'S PROPOSAL

TO: The City of Central Point
140 S. Third St.
Central Point, OR 97502

READ CAREFULLY

THE BID IS THE BIDDER'S OFFER TO ENTER INTO A CONTRACT WHICH, IF THE BID IS ACCEPTED FOR AWARD, BINDS THE BIDDER TO A CONTRACT AND THE TERMS AND CONDITIONS CONTAINED IN THE INVITATION TO BID INCLUDING THE ATTACHED CONTRACT. A BIDDER SHALL NOT MAKE THE BID CONTINGENT UPON THE OWNER'S ACCEPTANCE OF SPECIFICATIONS OR CONTRACT TERMS THAT CONFLICT WITH OR ARE IN ADDITION TO THOSE ADVERTISED IN THE INVITATION TO BID. SIGNING THIS BIDDER'S PROPOSAL AND THE FOLLOWING BID SCHEDULE AND SIGNATURE PAGE REPRESENTS A BID AND IS CONSIDERED THE BIDDER'S OFFER.

PROPOSAL

The undersigned, hereinafter called the Bidder, declares and certifies that:

- 1. The undersigned is the authorized representative of the Bidder, that the information provided in this Bid is true and accurate, and that providing incorrect or incomplete information may be cause for Bid rejection or contract termination;
- 2. The Bidder has read and understands all Bid (proposal) instructions, specifications, and terms and conditions contained herein (including the attachments listed in this document) for the public improvement project on **Central Point Council Chambers Renovation** and that this proposal is made according to the provisions and under the terms of the Contract Documents bound herewith; the Standard Specifications; and in accordance with the accompanying Plans, Standard Specifications, Certifications, the following Addenda, if any, have been received, have been considered and are included in proposed Bid Sum:

| Addenda # | Dated |
|-----------|-------|
| _____ | _____ |
| _____ | _____ |
| _____ | _____ |

and all other Contract Documents are hereby made a part of this proposal.

- 3. The Bidder or its designee has visited the site of the proposed work and have made diligent inquiry and become fully acquainted with conditions relating to construction and labor, and understands fully the facilities, difficulties, and restrictions involved in the construction of the work under the Contract; that Bidder is satisfied as to the quantities involved, including materials, and including the fact that the quantities of work and materials included herein is approximate only, and is intended only to indicate the general nature and scope of the work.
- 4. This Bid is an offer that has been:
 - a) Arrived at independently, without, for the purpose of restricting competition, any consultation, communication, or agreement with any other Bidder or competitor relating to (i) those prices, (ii) the intention to submit an offer, or (iii) the methods or factors used to calculate the prices offered;
 - b) The prices in this offer have not been and will not be knowingly disclosed by the Bidder, directly or indirectly, to any other Bidder or competitor before Bid opening (in the case of a sealed Bid solicitation) or contract award (in the case of a negotiated solicitation) unless otherwise required by law; and
 - c) No attempt has been made or will be made by the Bidder to induce any other concern to submit or not to submit an offer for the purpose of restricting competition.

(If the Bidder deletes or modifies subparagraph 4 above, the Bidder must furnish with its offer a signed statement setting forth in detail the circumstances of the disclosure.)

- 5. If this proposal is accepted, Bidder will contract with the Board of Commissioners for the public improvement project on **Central Point Council Chambers Renovation** and will:
 - a) Be bound to and will comply with all Contract requirements, specifications, and terms and conditions contained herein; and
 - b) Provide all the necessary equipment, materials, tools, apparatus and labor to perform the work in accordance with the Plans and the Contract Documents;
 - c) Agree to complete the construction of the project in all respects on or before the fixed date specified in the Special Provisions, all in accordance with the Contract Documents.
 - d) Agree to comply with the all applicable sections of ORS Chapter 279, 279A-279C and other Oregon and Federal law.
- 6. In the event the Bidder is awarded the Contract and shall fail to complete the work within the time limit or extended time limit agreed upon, as more particularly set forth in the Contract Documents, liquidated damages shall be paid to the County at the rate specified in the Standard Specifications until the work shall have been finished as provided by the Contract Documents.
- 7. If this proposal is accepted, Bidder will, within seven (7) calendar days after notification of acceptance, deliver to the County Board of Commissioners the Performance Bond as required in the Contract Documents. Furthermore:
 - a) Bidder will not begin work under the Contract until a Performance Bond has been filed with the County. If the Bidder shall fail or refuse to furnish the specified Performance Bond within seven (7) calendar days after receipt of notification of acceptance of his proposal, then, in that event, the Contract shall be automatically terminated and the Bid security deposited

Attachment: Outlier Bidder Certificate (1157 : City Council Chambers Renovation Project Contract Approval)

herewith according to the conditions of the Advertisement for Bids and Information for Bidders, shall be retained by the County as liquidated damages; and it is agreed that the said sum is a fair measure of the amount of damage the County will sustain in case the Bidder shall fail or refuse to enter into the Contract for the said work and to furnish the Performance Bond as specified in the Contract Documents. Bid security in the form of a certified check shall be subject to the same requirements as a Bid Bond.

- b) If the Bidder is awarded a construction contract on this proposal, the Surety who will provide the Performance Bond will be TRAVELERS BOND & SPECIALTY INSURANCE whose address is 707 W MADON AVE STE 300
SPokane WA 99201

KNOW ALL MEN BY THESE PRESENTS that we do hereby agree to perform the work under the terms of this Contract as encompassed in the attached Bid Schedule and all of the above:

The Bidder further declares that it will accept the unit prices and/or lump sum prices as hereinafter written in the Bid Schedule of this proposal as full payment for the proposed work, and as such, Bidder, the undersigned, hereby offer to enter into a Contract to perform the Work for the Sum of:

\$ 149,006.⁰⁰ dollars ONE HUNDRED FORTY NINE THOUSAND SIX DOLLARS EVEN. (write dollar figure).

Bidder has included the required Bid Security as required by the Instruction to Bidders.

All applicable federal taxes are included and State of Oregon and The City of Central Point taxes and fees are included in the Contract Sum. (The City of Central Point taxes and fees will be paid by owner).

[Signature]
Bidders duly authorized representative

Contractor's Board No. 217660

THIS SECTION TO BE COMPLETED BY THE CITY OF CENTRAL POINT

OWNERS ACCEPTANCE OF BIDDER'S OFFER

The City of Central Point, hereby awards a contract to the above Bidder and accepts Bidder's offer for the Sum offered for the item(s) and/or service(s) designated on the Bid as:

Contract #: N/A
Project: CENTRAL POINT COUNCIL CHAMBERS RENOVATION

Attachment: Outlier Bidder Certificate (1157 : City Council Chambers Renovation Project Contract Approval)

CITY OF CENTRAL POINT COUNCIL CHAMBER RENOVATION

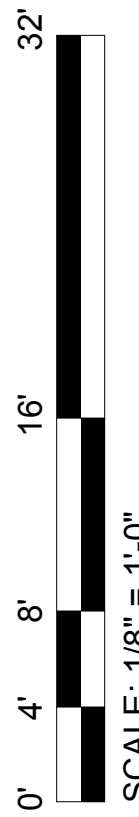
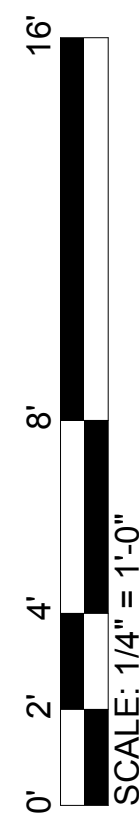
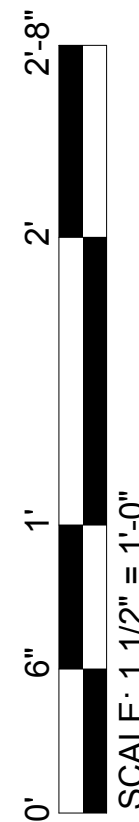
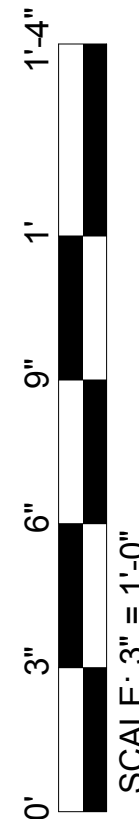

8/2/2018 10:12:28 AM Central File Location Input: Manage -> Settings -> Project Information -> Central File Location

| | | | | | | | | |
|--|--|--|--|--|---------------------------------|---------------------------------|--|---|
| | | | | | MECHANICAL | ELECTRICAL | ARCHITECT | OWNER |
| | | | | | NAME DESIGN BUILD CONTRACTOR | NAME DESIGN BUILD CONTRACTOR | ORW ARCHITECTURE 2950 EAST BARNETT ROAD MEDFORD, OREGON 97504 ARCHITECT OF RECORD JEFFREY BENDER JEFF@ORWARCH.COM CONTACT: MICHAEL CASTRO PROJECT MANAGER PHONE: 541.779.5237 FAX: 541.772.8472 EMAIL: MICHAEL@ORWARCH.COM | CITY OF CENTRAL POINT 140 S 3rd STREET CENTRAL POINT, OR 97502 CONTACT: MATT SAMITORE PARKS AND PUBLIC WORKS DIRECTOR PHONE: 541.664.3321 FAX: 541.664.6384 EMAIL: matt.samitore@centralpointoregon.gov |

LEGEND AND SYMBOLS

DRAWING TITLE INDICATES DRAWING NUMBER, NAME & SCALE

ELEVATION REFERENCE REFER TO INDICATED DRAWING

DETAIL REFERENCE REFER TO INDICATED DRAWING

BUILDING SECTION REFERENCE (WALL SECTIONS UNFILLED ARROW) INDICATES DIRECTION & POINT WHERE SECTION IS TAKEN

ROOM NAME/NUMBER SYMBOL REFER TO SCHEDULES

DOOR SYMBOL REFER TO DOOR SCHEDULE

DOOR LEGEND INDICATES DOOR SYMBOLS ON PLAN

SPOT ELEVATION INDICATED HEIGHT OF FLOOR

COLUMN GRID SYMBOL COLUMN GRID LINE DESIGNATION

REVISION CLOUD

REVISION NUMBER 'DELTA' OCCURS AT EACH CHANGE

FINISH PLAN SYMBOL OCCURS ON FINISH PLAN

EGRESS EXIT LGHT OCCURS ON EGRESS PLAN

View Name
1/8" = 1'-0"

DRAWING NAME
DRAWING SCALE

SHEET WHERE SHOWN
DRAWING NUMBER

SIMILAR TO REFERENCE
DETAIL DESIGNATION SHEET WHERE SHOWN

SIMILAR TO REFERENCE
DRAWING DESIGNATION SHEET WHERE SHOWN

ROOM NAME
ROOM NAME
ROOM NUMBER
ROOM AREA

DOOR NUMBER
DOOR SEALS
FIRE RATING

ELEVATION

GRID NUMBER

PROJECT NORTH
TRUE NORTH

REVISED AREA
REVISION NUMBER

WEST WALL FINISH
NORTH WALL FINISH
ROOM NUMBER
ROOM ABBREVIATION
EAST WALL FINISH
CEILING FINISH
FLOOR FINISH & BASE
SOUTH WALL FINISH

ILLUMINATED ARROW
BRACKET WALL MOUNT
FLUSH WALL MOUNT
ILLUMINATION DIRECTION



ABBREVIATIONS

| | | | | | | | | | |
|------|---|-------|--------------------------------|--------|--|------|--------------------------------------|--------|--------------------------------|
| ACT | ACOUSTIC CEILING TILE | DBL | DOUBLE | GA | GYPSUM ASSOCIATION | OD | OUTSIDE DIAMETER | SPECS | SPECIFICATIONS |
| ADJ | ADJACENT | DF | DRINKING FOUNTAIN | GALV | GALVANIZED | OFCI | OWNER FURNISHED CONTRACTOR INSTALLED | SS | STAINLESS STEEL |
| AFF | ABOVE FINISHED FLOOR | DIA | DIAMETER | GW | GYPSUM WALL BOARD | OFOI | OWNER FURNISHED OWNER INSTALLED | STL | STEEL |
| AL | ALIGN | DIMS | DIMENSIONS | HC | HANDICAP | OPNG | OPENING | STRUCT | STRUCTURAL/STRUCTURE |
| ALT | ALTERNATE | DW | DISHWASHER | HDBD | HARDBOARD | OVHG | OVERHANG | SQFT | SQUARE FEET |
| BO | BOTTOM OF | EJ | EXPANSION JOINT | HDR | HEADER | PC | PAINT COLOR | TO | TOP OF |
| BOS | BOTTOM OF STRUCTURE | EA | EACH | HDWD | HARDWOOD | PLAM | PLASTIC LAMINATED | TS | TUBE STEEL |
| BD | BOARD | ELECT | ELECTRICAL | HGT | HEIGHT | PT | PAINT | TYP | TYPICAL |
| BLDG | BUILDING | EQ | EQUAL(Y) | HR | HOUR | PTW | PRESSURE TREATED WOOD | UNO | UNLESS NOTED OTHERWISE |
| BM | BEAM | EX | EXISTING | HVAC | HEATING/VENTILATING/AIR CONDITIONING | PSF | POUNDS PER SQUARE FOOT | UL | UNDERWRITERS LABORATORY |
| BS | BACKSPASH | EXT | EXTERIOR | HW | HOT WATER | PWC | PLASTIC WALL COVERING | UTIL | UTILITY |
| CFCI | CONTRACTOR FURNISHED CONTRACTOR INSTALLED | FD | FLOOR DRAIN | INSUL | INSULATION | PWD | PLYWOOD | V-1HR | TYPE 5, 1 HOUR |
| | | FEC | FIRE EXTINGUISHER CABINET | INT | INTERIOR | PWP | PLASTIC WALL PANEL | VCT | VINYL COMPOSITION TILE |
| | | FF | FINISHED FLOOR / FINISHED FACE | LPG | LIQUID PROPANE GAS | RB | RUBBER BASE | VERT | VERTICAL |
| | | FIN | FINISH(ED) | MAX | MAXIMUM | REF | REFRIGERATOR | VEST | VESTIBULE |
| | | FNG | FRAMING | MDL | MODEL | RD | ROOF DRAIN | V-NR | TYPE 5, NON-RATED |
| | | FOM | FACE OF MASONRY | MECH | MECHANICAL | RM | ROOM | VWC | VINYL WALL COVERING |
| | | FOS | FACE OF STUD/STRUCTURE | MFR | MANUFACTURER | RO | ROUGH OPENING | WC | WATER CLOSET |
| | | FR | FIRE RESISTANT | MIN | MINIMUM | RSF | RESILIENT SHEET FLOORING | WBG | WALL BUMPER GUARD |
| | | FRP | FIBER-REINFORCED PLASTIC | MISC | MISCELLANEOUS | SEP | SEPARATION | WD | WOOD |
| | | FRM | FRAMING | MTL | METAL | SF | STOREFRONT | WDW | WINDOW |
| | | FRZR | FREEZER | MW | MICROWAVE | SHTG | SHEATHING | WF | WIDE FLANGE |
| | | FTG | FOOTING | MWRGWB | MOLD & WATER RESISTANT GYPSUM WALL BOARD | SIM | SIMILAR | WP | WATER PROOF |
| | | GC | GENERAL CONTRACTOR | NIC | NOT IN CONTRACT | SM | SHEET METAL | WRGB | WEATHER RESISTANT GYPSUM BOARD |
| | | CW | CURTAIN WALL | OC | ON CENTER | | | | |
| | | D-B | DESIGN BUILD | OCC | OCCUPANCY | | | | |
| | | | | GB | GRAB BAR | | | | |

PROJECT INFORMATION

LOCATION: - 140 S 3rd Street, Central Point OR 97502
 MAP & TAX LOT: - 372W11BB 1001
 BUILDING FOOTPRINT: - 3036 SF
 BUILDING TYPE: -
 DESIGN CRITERIA FOR CITY OF CENTRAL POINT: N/A

CODES

2014 Oregon Structural Specialty Code (OSSC)
 2014 Oregon Energy Efficiency Specialty Code (OEESC)
 2014 Oregon Fire Code (OFC)
 2014 Oregon Electrical Specialty Code (ORSC)
 2014 Oregon Mechanical Specialty Code (OMSC)
 2014 Oregon Plumbing Specialty Code (OPSC)
 2010 Oregon Solar Installation Specialty Code (OSISC)
 2011 Oregon Reach Code (ORC)
 NFPA 13
 NFPA 72

GENERAL NOTES

- DO NOT SCALE DRAWINGS. CONTRACTOR SHALL VERIFY ALL DIMENSIONS AND EXISTING SITE DIMENSIONS. IF DISCREPANCIES ARE FOUND, THE ARCHITECT SHALL BE NOTIFIED IMMEDIATELY FOR CLARIFICATION.
- UNLESS SHOWN OTHERWISE, ALL DAMAGE CAUSED BY NEW WORK TO EXISTING AREAS OF THE SITE, CONSTRUCTION, FINISH CONSTRUCTION, ELECTRICAL OR MECHANICAL SYSTEMS SHALL BE REPAIRED TO MATCH EXISTING CONDITIONS OR AS FOUND PRIOR TO ANY DAMAGE.
- ALL WORK SHALL BE IN ACCORDANCE WITH THE FIRE AND LIFE SAFETY CODES.
- THE CONTRACTOR SHALL THOROUGHLY FAMILIARIZE THEMSELVES WITH THE SCOPE OF THE WORK AND SITE ACCESSIBILITY. THE CONTRACTOR IS REMINDED THAT THE PROJECT DRAWINGS INDICATE THE CONDITIONS AT THE SITE AS IT EXISTED. DEVIATIONS ENCOUNTERED DURING THE WORK SHALL BE BROUGHT TO THE ATTENTION OF THE ARCHITECT FOR CLARIFICATION BEFORE PROCEEDING.
- THE CONTRACTOR SHALL BE RESPONSIBLE FOR THE PROTECTION OF ALL EXISTING STRUCTURES AT THE WORK AREA FROM WEATHER AND OTHER INCLEMENT CONDITIONS. ANY DAMAGE INCURRED DUE TO THE FAILURE BY THE CONTRACTOR TO PROPERLY PROTECT SUCH WORK SHALL BE REPAIRED AT CONTRACTOR EXPENSE.
- THE CONTRACTOR SHALL DISPOSE OF ALL REMOVED AND/OR DEMOLISHED MATERIAL, WASTE & DEBRIS CAUSED BY THE NEW WORK. THIS MATERIAL SHALL BE REMOVED FROM THE PROPERTY AND TAKEN TO A LEGALLY-OPERATED DISPOSAL SITE.
- ALL CONSTRUCTION TECHNIQUES, MATERIALS, AND FINISHES SHALL BE AS REQUIRED BY THE APPROPRIATE CODE AUTHORITIES. INSTALLATION SHALL FOLLOW THE MANUFACTURERS PUBLISHED SPECIFICATIONS AND/OR TRADE STANDARDS IN ADDITION TO MEETING OR EXCEEDING THE DESIGN STANDARDS.
- ALL WEATHER EXPOSED SURFACES SHALL HAVE A WEATHER RESISTIVE BARRIER TO PROTECT THE INTERIOR WALL COVERING AND THE EXTERIOR OPENINGS SHALL BE FLASHED IN SUCH A MANNER AS TO MAKE THEM WATERPROOF.
- ALL DIMENSIONS FROM FACE OF FINISH UNLESS NOTED OTHERWISE.

SHEET INDEX

| ARCHITECTURAL | |
|---------------|---|
| A0.00 | TITLE SHEET AND DRAWING INDEX |
| A2.01 | DEMO PLAN - LEVEL 01 |
| A3.10 | FLOOR PLAN - LEVEL 01 |
| A4.01 | ENLARGED FIXTURE PLAN - DAIS |
| A4.02 | ENLARGED FIXTURE ELEVATIONS - DAIS |
| A4.03 | FIXTURE DETAILS - DAIS |
| A4.04 | ENLARGED FIXTURE PLAN AND DETAILS - LECTERN |
| A4.05 | ENLARGED ELEVATIONS - BACK WALL FIXTURE |
| A4.06 | PERSPECTIVE VIEWS |

2950 EAST BARNETT ROAD
MEDFORD, OR 97504
541.779.5237
541.772.8472

City of Central Point - Council Chamber Renovation
140 S 3rd Street, Central Point, Oregon 97502
CITY OF CENTRAL POINT

TITLE SHEET AND DRAWING INDEX

| | | |
|---------|--------------|------|
| PROJECT | 1810 | |
| DATE | JULY 31 2018 | |
| No. | Description | Date |
| | | |
| | | |
| | | |
| | | |

A0.00

Attachment: Construction Drawings (1157 : City Council Chambers Renovation Project Contract Approval)

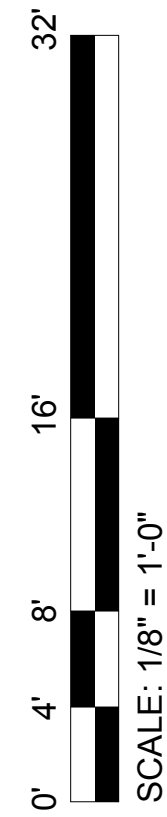
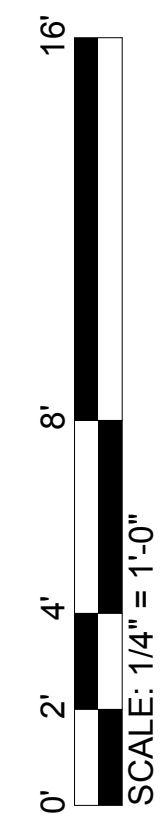
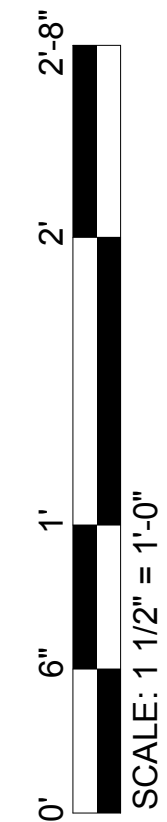
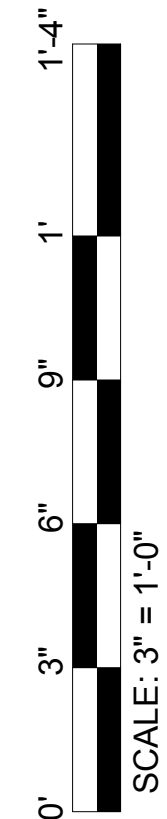

8/2/2018 10:12:29 AM Central File Location Input: Manage -> Settings -> Project Information -> Central File Location

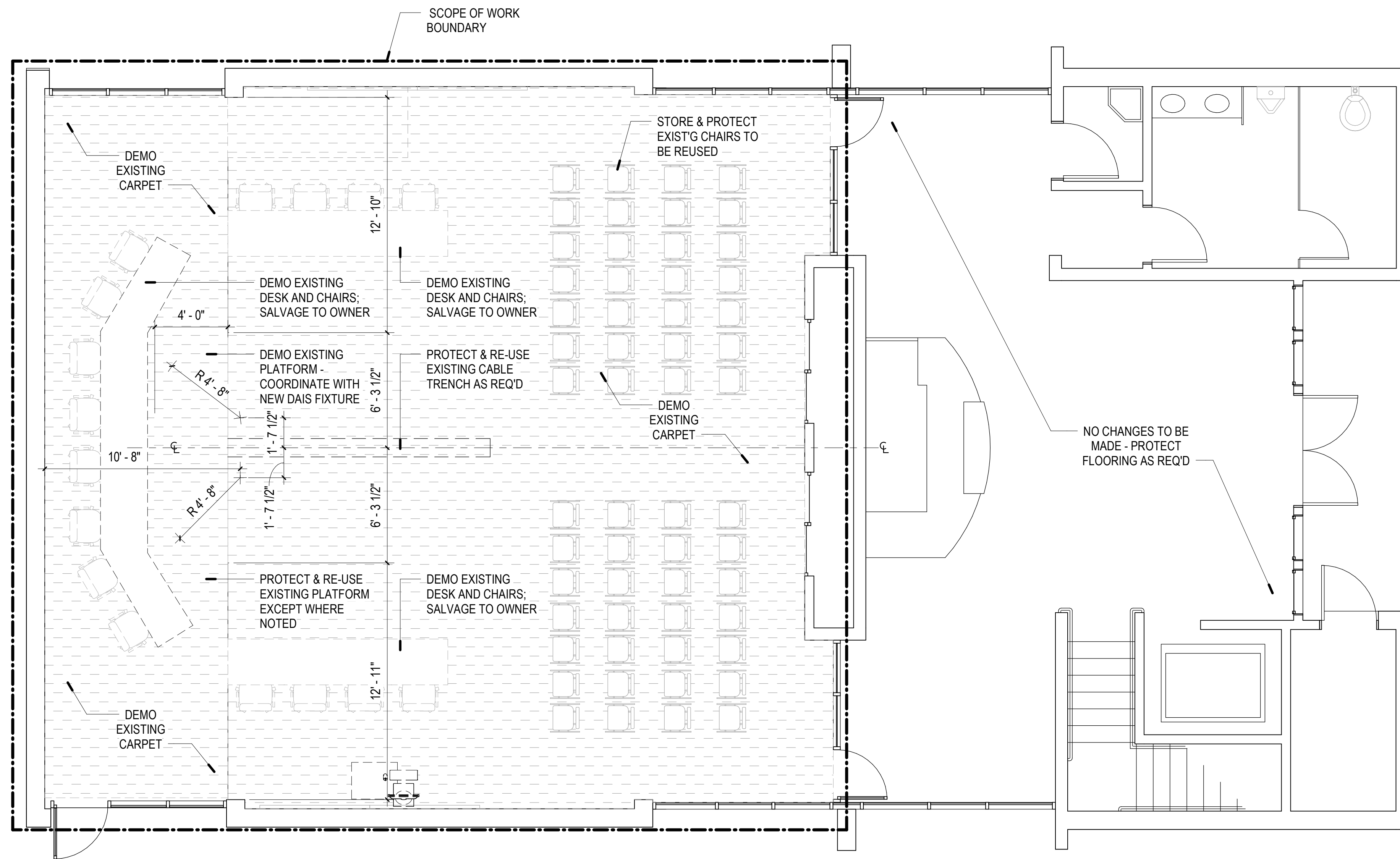

1 DEMO FLOOR PLAN - LEVEL 01
1/4" = 1'-0"

GENERAL NOTES

- THE CONTRACTOR SHALL:
- A. COORDINATE ALL DEMOLITION/PHASING EFFORTS WITH THE ARCHITECT AND OWNER'S REPRESENTATIVES. EVERY EFFORT SHALL BE MADE TO MINIMIZE DISRUPTION OF OWNER'S OPERATIONS AND TO PROVIDE BUILDING USER'S SAFETY. EXCESSIVE NOISE OR VIBRATIONS SHALL BE PRE-APPROVED AND COORDINATED WITH THE OWNER'S REPRESENTATIVE.
 - B. DISCONNECT & CAP UTILITIES AS NEEDED PER CURRENT APPLICABLE CODES.
 - C. VERIFY ALL EXISTING CONSTRUCTION, DIMENSIONS AND ELEVATIONS AND NOTIFY THE ARCHITECT OF ANY DISCREPANCIES.
 - D. THE OWNER SHALL RESERVE THE RIGHT TO SALVAGE ALL MATERIALS.
 - E. PROVIDE PROTECTION FOR ALL EXISTING BUILDING MATERIALS AND EQUIPMENT FROM DAMAGE DUE TO ANY DEMOLITION OR CONSTRUCTION RELATED INCIDENT PERFORMED UNDER THIS CONTRACT.
 - F. REPAIR OR REPLACE ITEMS THAT ARE DAMAGED AS A RESULT OF DEMOLITION OR CONSTRUCTION TO MATCH EXISTING FINISH AND/OR CONDITION.
 - G. EXISTING MATERIALS SHALL NOT BE REUSED UNLESS NOTED OTHERWISE, OR AS AUTHORIZED BY THE ARCHITECT.
 - H. PATCH FLOOR AND CEILING PENETRATIONS RESULTING FROM REMOVAL, OR REROUTING OF NEW OR EXISTING PIPING, DUCTWORK, CONDUIT, ETC. FINISH AS REQUIRED FOR NEW OR EXISTING ADJACENT SURFACES.

LEGEND

- EXISTING TO REMAIN
- TO BE DEMOLISHED
- CARPET TO BE REMOVED

NOTE:
DIMENSIONS ARE APPROXIMATE
VERIFY ALL DIMENSIONS IN
FIELD PRIOR TO CONSTRUCTION

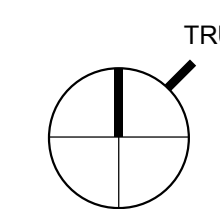

2050 EAST BARNETT ROAD
PORTLAND, OREGON 97204
503.417.7799
503.417.7728

City of Central Point - Council Chamber Renovation
140 S 3rd Street, Central Point, Oregon 97502
CITY OF CENTRAL POINT

PROJECT 1810
DATE JULY 31 2018

| No. | Description | Date |
|-----|-------------|------|
| | | |
| | | |
| | | |
| | | |

DEMO PLAN - LEVEL 01

PROJECT 1810
DATE JULY 31 2018

| No. | Description | Date |
|-----|-------------|------|
| | | |
| | | |
| | | |
| | | |

A2.01

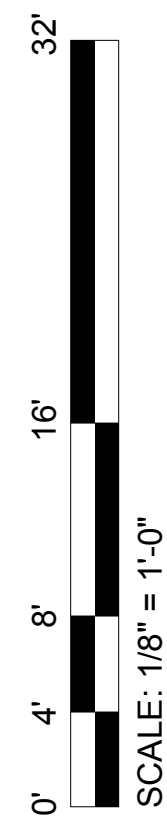
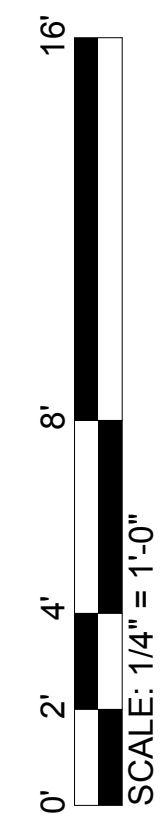
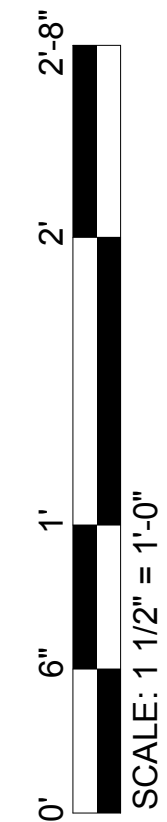
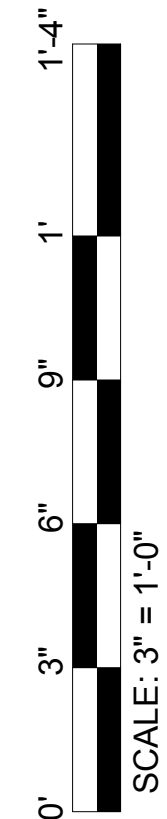

8/2/2018 10:12:32 AM Central File Location Input: Manage -> Settings -> Project Information -> Central File Location

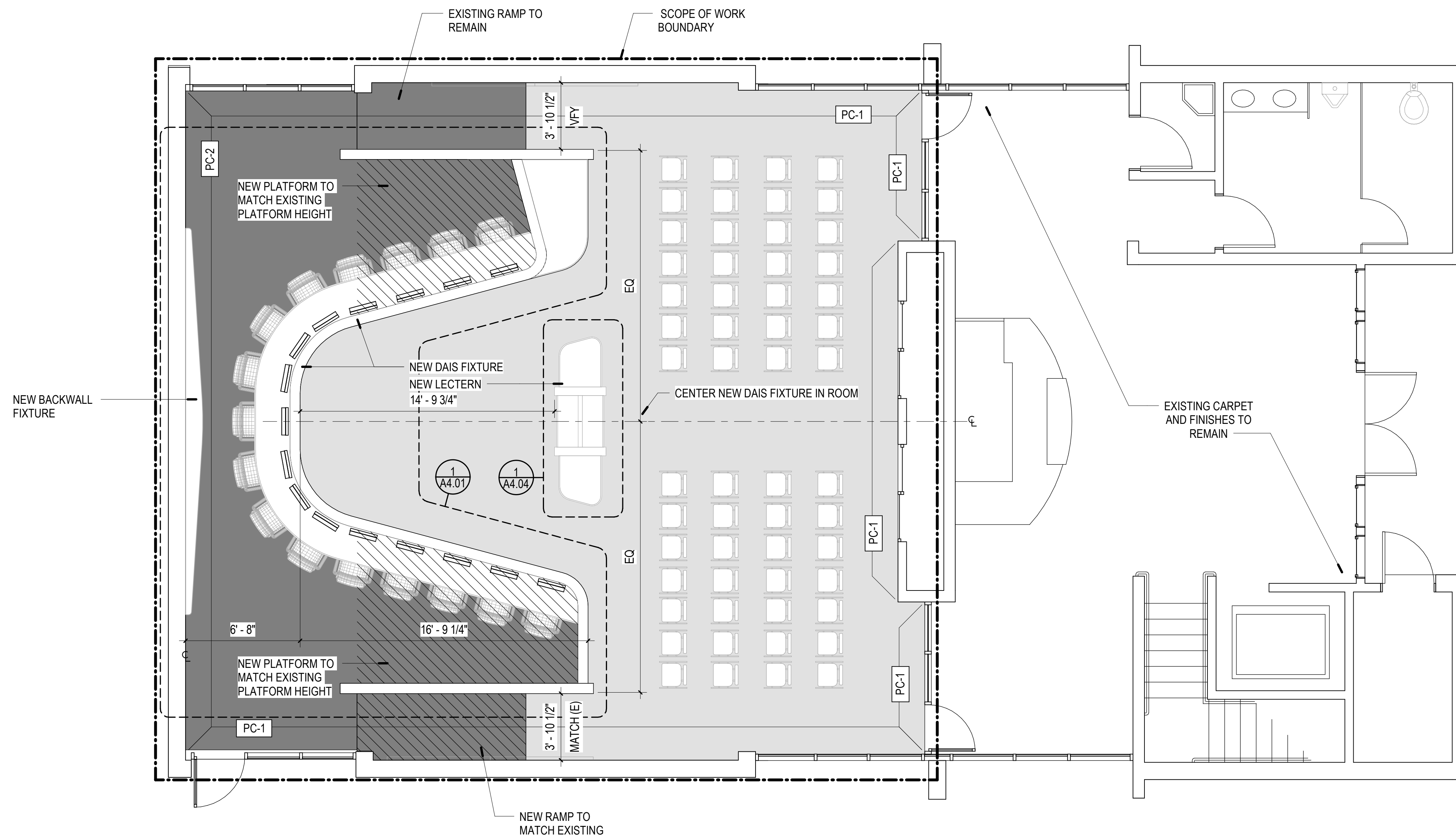

1 FLOOR PLAN - LEVEL 01
1/4" = 1'-0"

LEGEND

- CARPET (CPT1)
MANUFACTURER: SHAW CONTRACT
COLLECTION: BEYOND THE FOLD
TYPE: FOLDED EDGE TILE 5T062 (18"X36")
COLOR: DOLPHIN OBSIDIAN 60505
INSTALLATION: BRICK
- CARPET (CPT2)
MANUFACTURER: SHAW CONTRACT
COLLECTION: BEYOND THE FOLD
TYPE: FOLDED TILE 5T060 (18"X36")
COLOR: DOLPHIN OBSIDIAN 60505
INSTALLATION: MONOLITHIC
- AREA OF PLATFORM & RAMP EXPANSION

WALL PAINT LEGEND

- PATCH AND REPAIR -
MATCH (E) PAINT AS
REQUIRED
- STANDARD ACCENT WALL COLOR
SHERWIN WILLIAMS
SW 6716 - DANCING GREEN

NOTE:
DIMENSIONS ARE APPROXIMATE
VERIFY ALL DIMENSIONS IN
FIELD PRIOR TO CONSTRUCTION

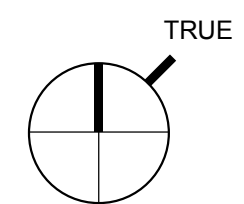

ORW
ARCHITECTURE
WWW.ORWARCHITECTURE.COM

2950 EAST BARNETT ROAD
PORTLAND, OREGON 97204
503.411.7799 • 503.754.1772 • 503.754.1772

City of Central Point - Council Chamber Renovation
140 S 3rd Street, Central Point, Oregon 97502
CITY OF CENTRAL POINT

FLOOR PLAN - LEVEL 01

| | | |
|---------|--------------|------|
| PROJECT | 1810 | |
| DATE | JULY 31 2018 | |
| No. | Description | Date |
| | | |
| | | |
| | | |

A3.10

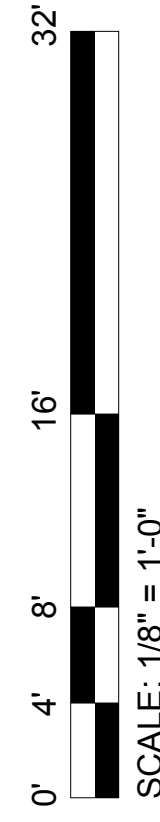
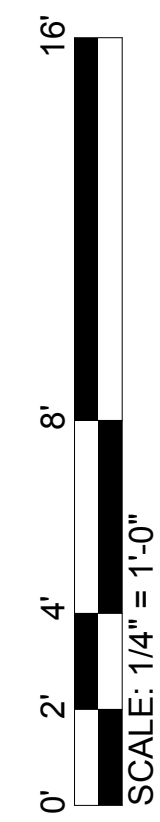
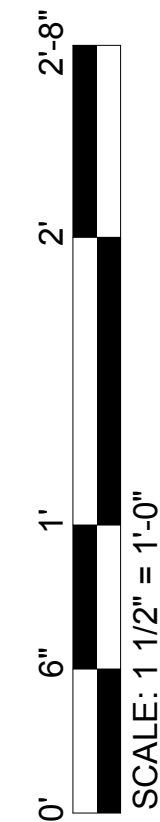
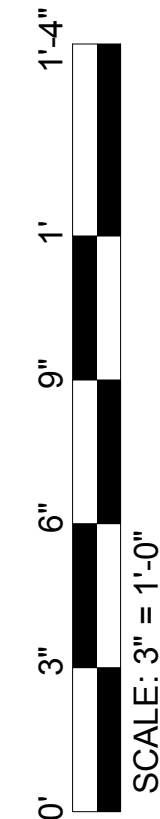

8/2/2018 10:12:33 AM Central File Location Input: Manage -> Settings -> Project Information -> Central File Location

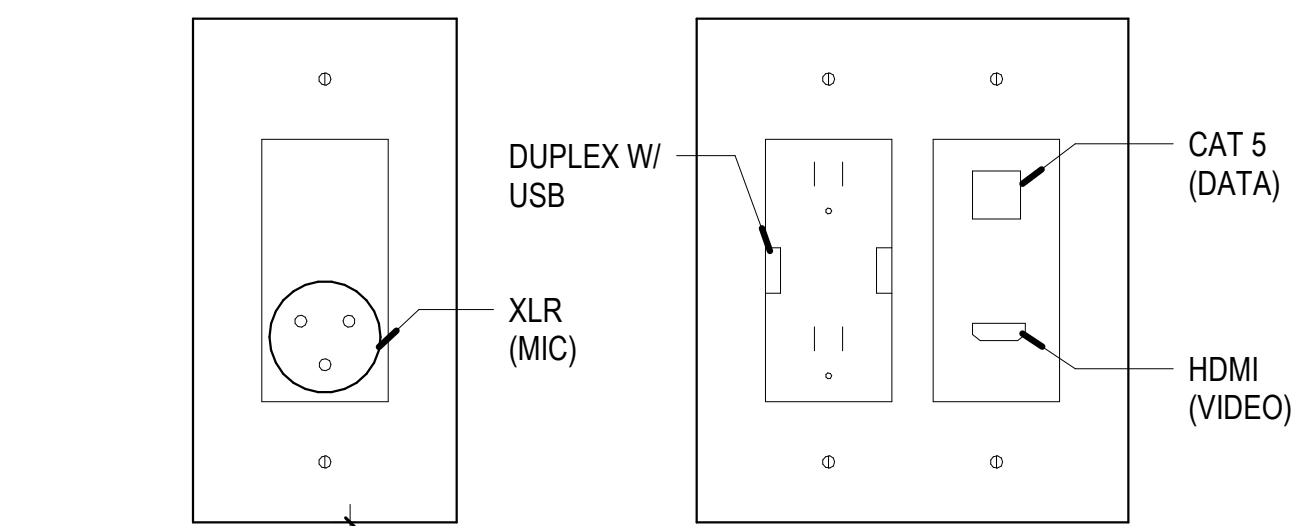

2 MONITOR RECEPTACLES
N.T.S.

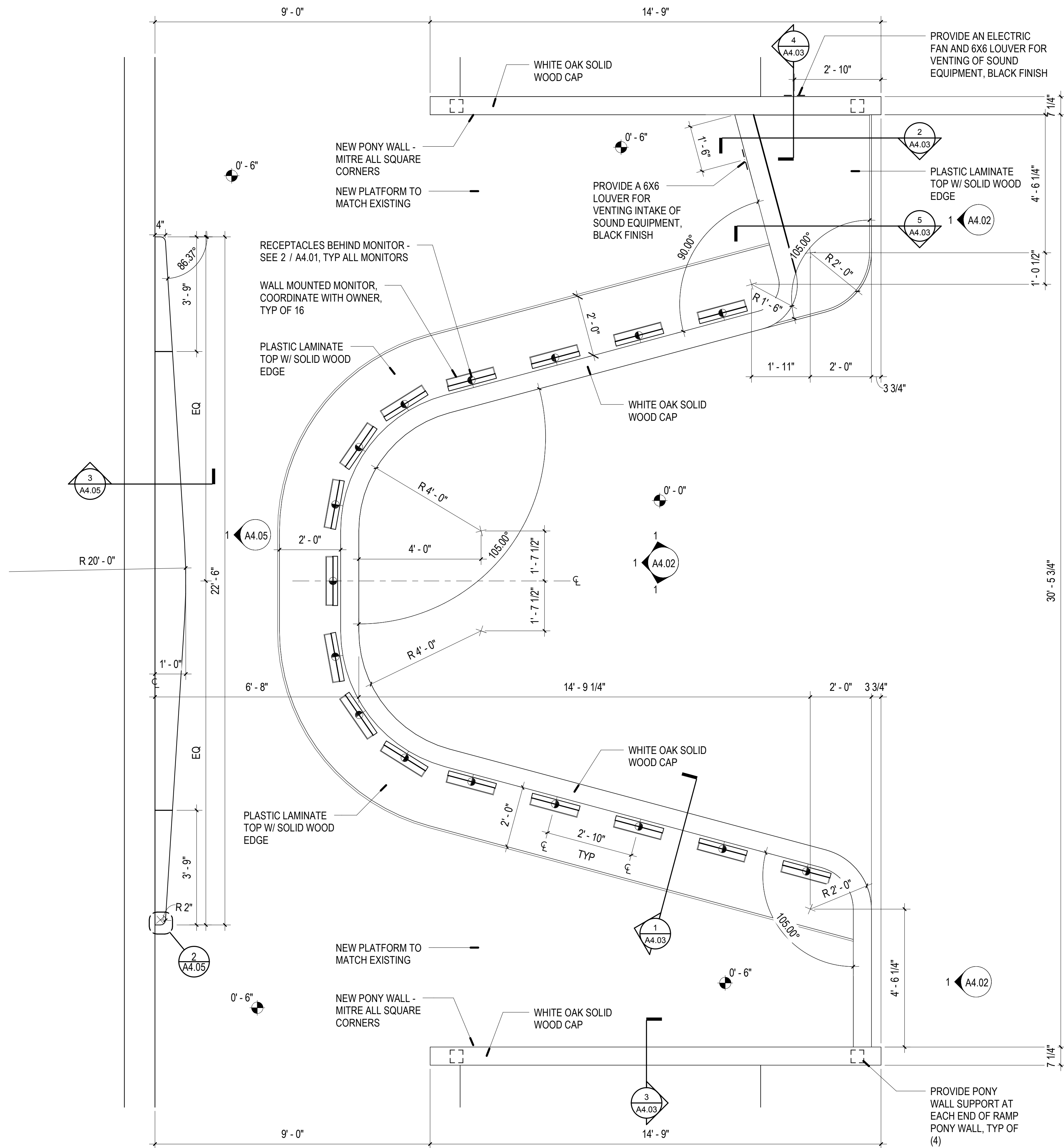

1 ENLARGED FLOOR PLAN - DAIS
1/2\"/>

NOTE:
DIMENSIONS ARE FACE OF
FINISH UNO



2050 EAST BARNETT ROAD
PORTLAND, OREGON 97204
503.41.779.5257
503.41.772.8472

City of Central Point - Council Chamber Renovation
140 S 3rd Street, Central Point, Oregon 97502
CITY OF CENTRAL POINT

ENLARGED FIXTURE PLAN - DAIS

| | | |
|---------|--------------|------|
| PROJECT | 1810 | |
| DATE | JULY 31 2018 | |
| No. | Description | Date |
| | | |
| | | |
| | | |

A4.01

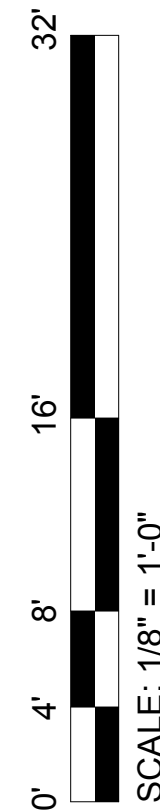
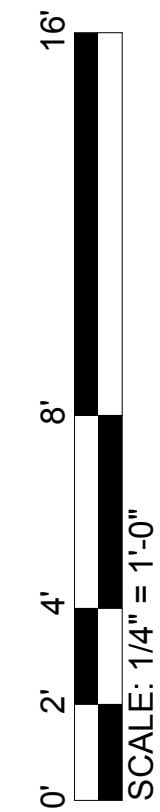
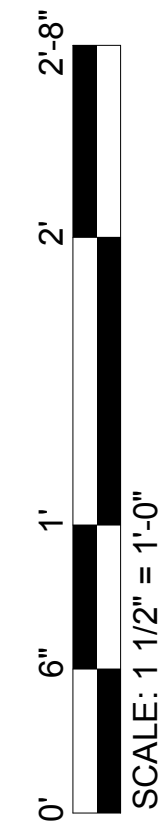
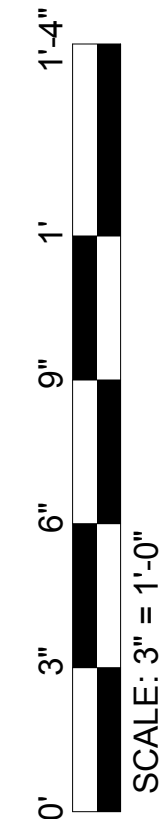

8/2/2018 10:12:33 AM Central File Location Input: Manage -> Settings -> Project Information -> Central File Location

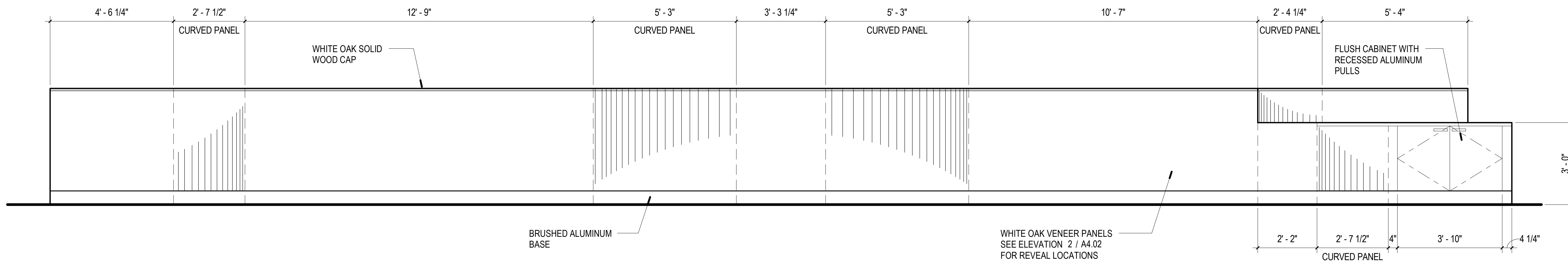

1 DAIS DEVELOPED ELEVATION - PANEL SIZES
1/2" = 1'-0"

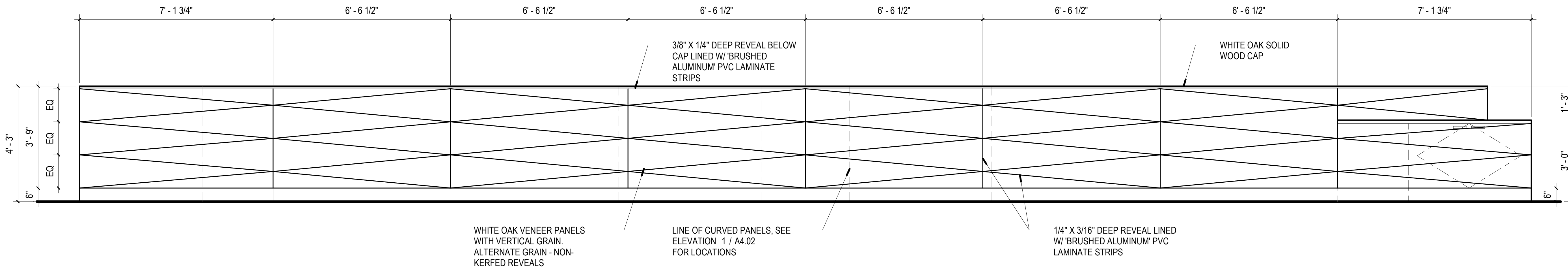

2 DAIS DEVELOPED ELEVATION - REVEAL LAYOUT
1/2" = 1'-0"

NOTE:
DIMENSIONS ARE APPROXIMATE
VERIFY ALL DIMENSIONS IN
FIELD PRIOR TO CONSTRUCTION



2050 EAST BARNETT ROAD
PORTLAND, OR 97204
503.417.7795
503.417.7728

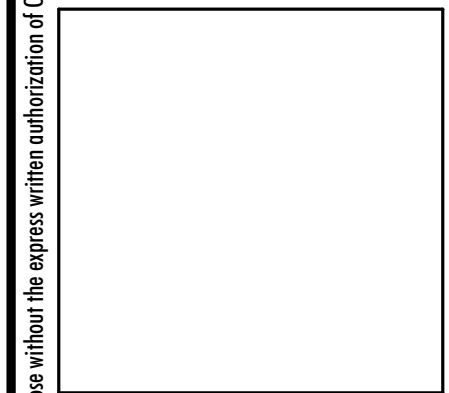

City of Central Point - Council Chamber Renovation
 140 S 3rd Street, Central Point, Oregon 97502
 CITY OF CENTRAL POINT

ENLARGED FIXTURE ELEVATIONS - DAIS

| | | |
|---------|--------------|------|
| PROJECT | 1810 | |
| DATE | JULY 31 2018 | |
| No. | Description | Date |
| | | |
| | | |
| | | |

A4.02

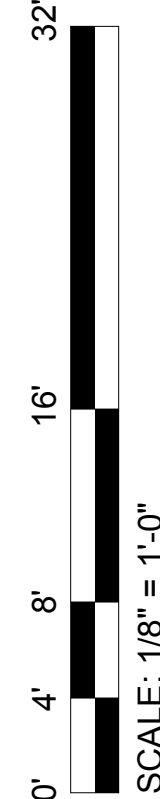
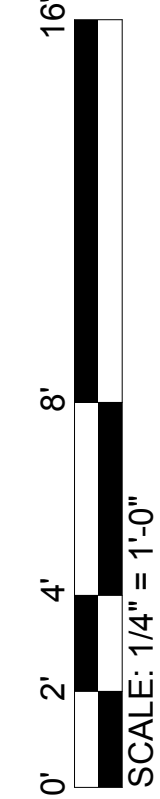
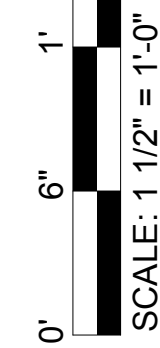

8/2/2018 10:12:34 AM Central File Location Input: Manage -> Settings -> Project Information -> Central File Location

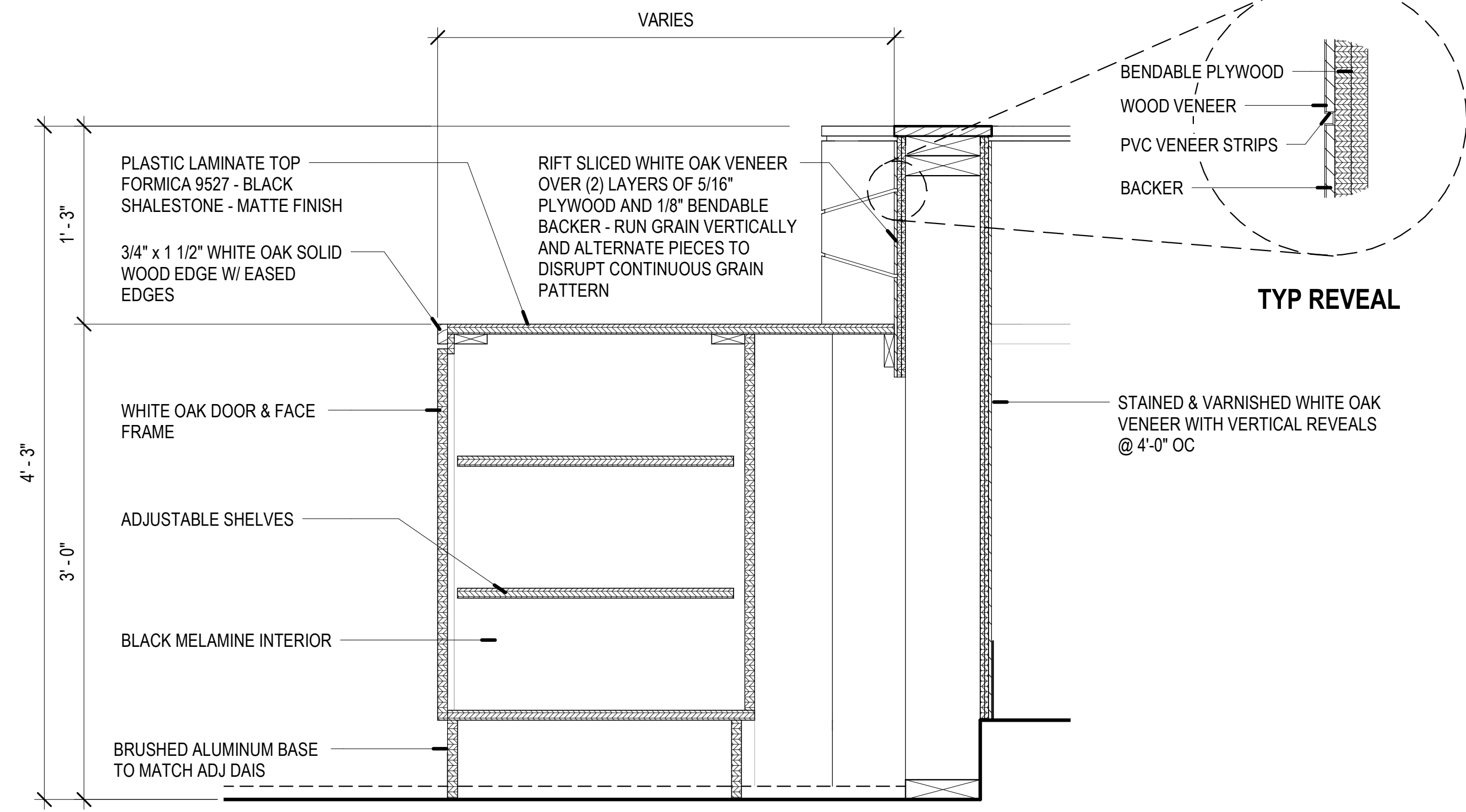

5 SECTION - CABINET @ SHELVING
1 1/2" = 1'-0"

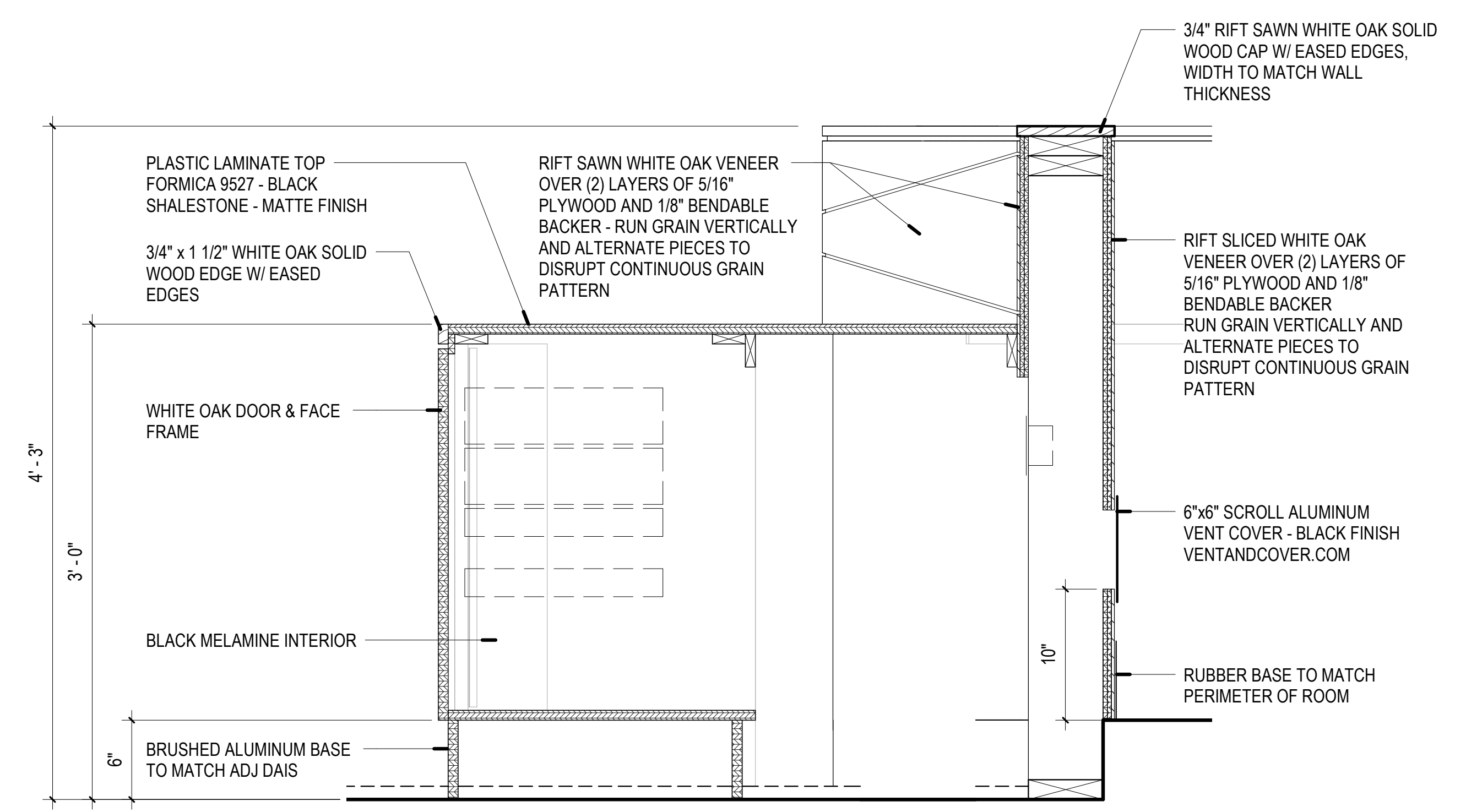

2 SECTION - CABINET @ RACK GEAR
1 1/2" = 1'-0"

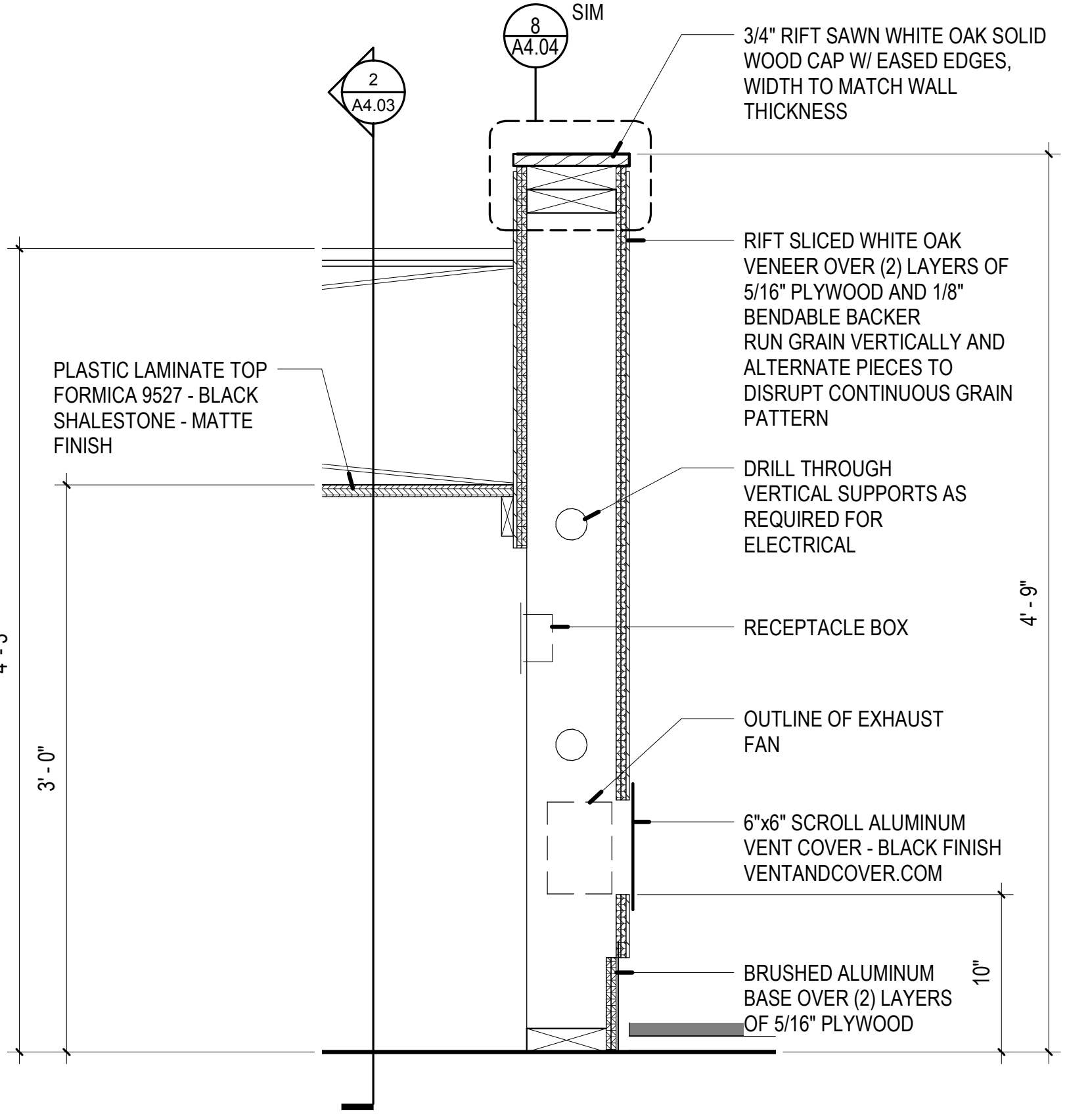

4 PONY WALL SECTION AT CABINET VENT
1 1/2" = 1'-0"

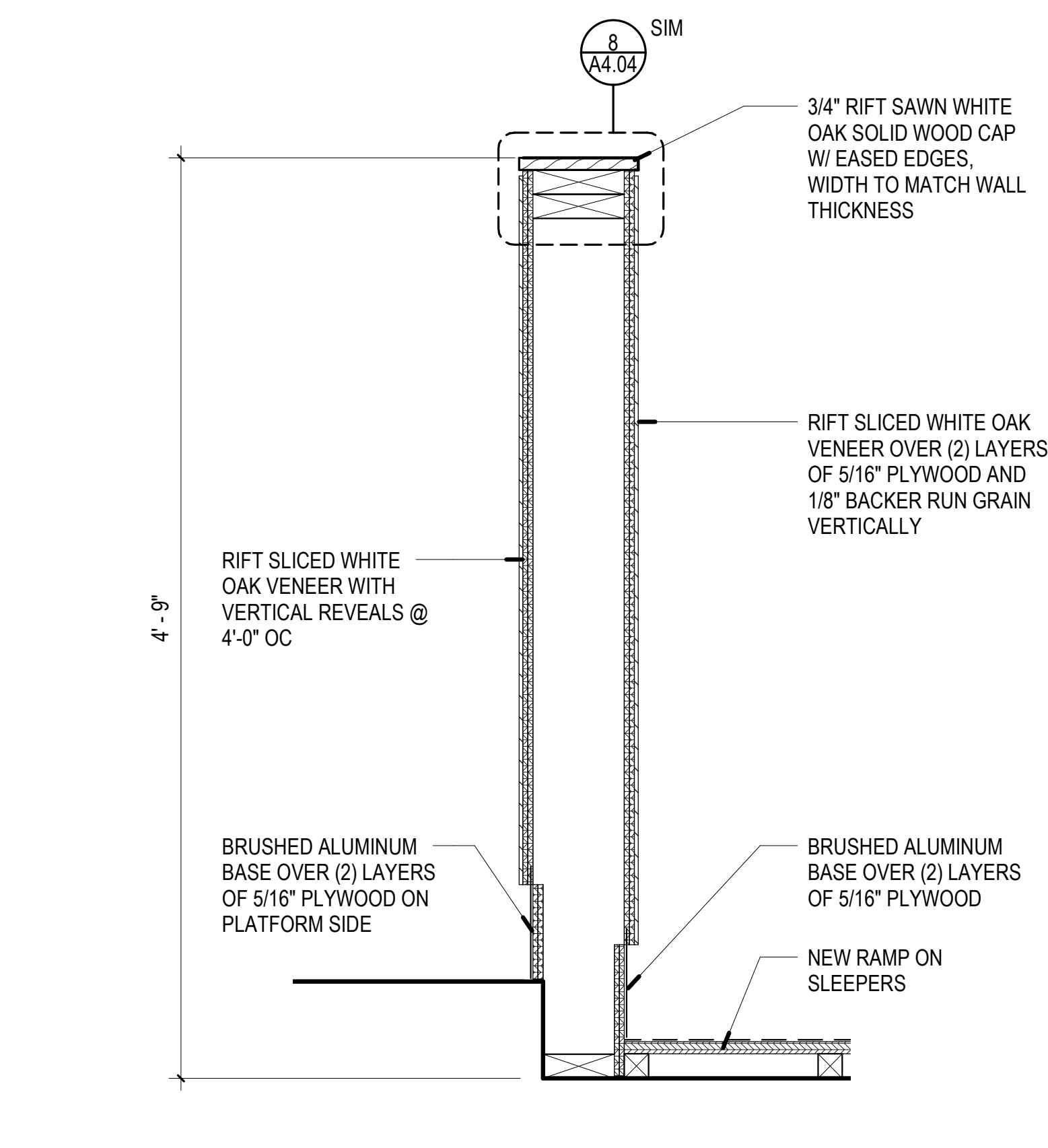

3 SECTION - LOW WALL AT RAMP
1 1/2" = 1'-0"

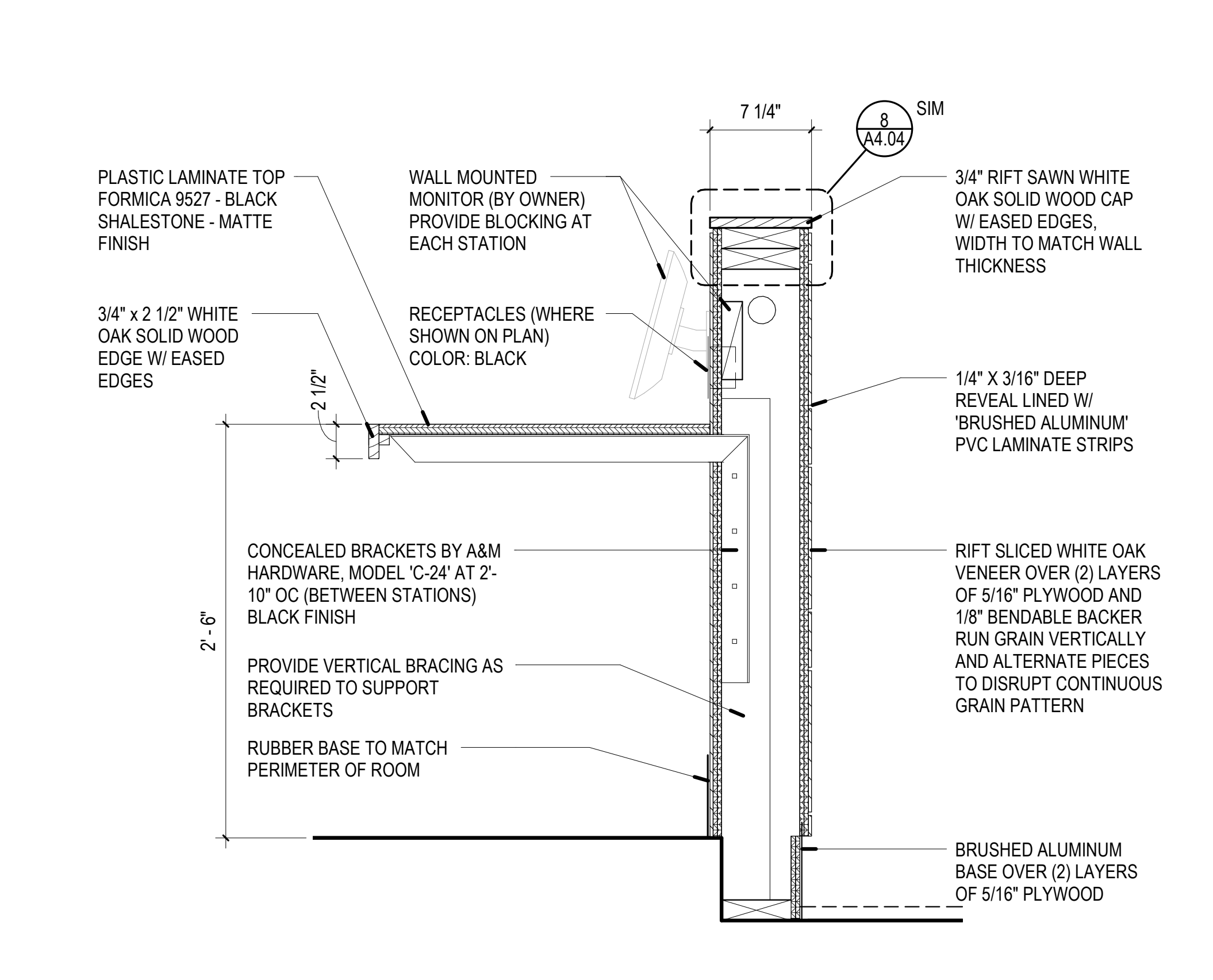

1 SECTION - DAIS WALL AT WORK TOP
1 1/2" = 1'-0"

ORW
ARCHITECTURE
www.orwarchitecture.com

2950 EAST BARNETT ROAD
PORTLAND, OREGON 97204
503.417.7799 • 503.778.8472

City of Central Point - Council Chamber Renovation
140 S 3rd Street, Central Point, Oregon 97502
CITY OF CENTRAL POINT

FIXTURE DETAILS - DAIS

| | | |
|---------|--------------|------|
| PROJECT | 1810 | |
| DATE | JULY 31 2018 | |
| No. | Description | Date |
| | | |
| | | |

A4.03

© 2018 Ogden Reeser Wilkerson Architecture. This document and the files and designs incorporated herein, as an instrument of professional service, shall remain the property of ORW Architecture, and shall not be reproduced, published or used, in whole or in part, for any other project or purpose without the express written authorization of ORW Architecture.

Attachment: Construction Drawings (1157 : City Council Chambers Renovation Project Contract Approval)

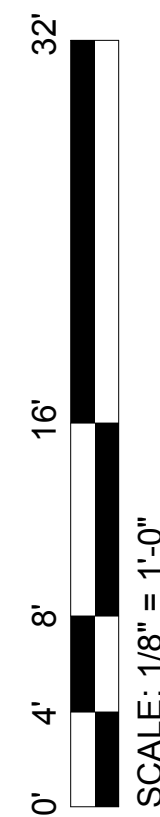
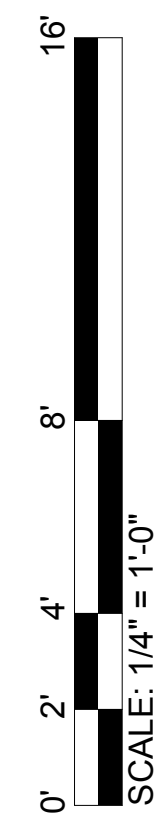
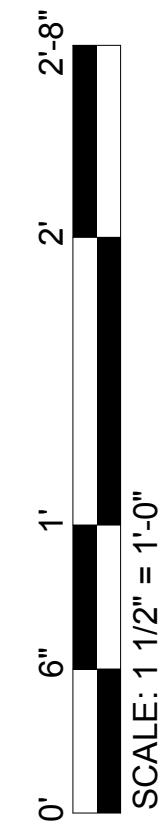
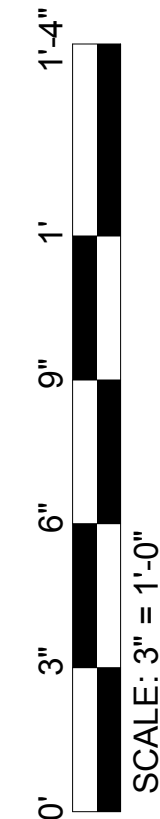

8/2/2018 10:12:35 AM Central File Location Input: Manage -> Settings -> Project Information -> Central File Location

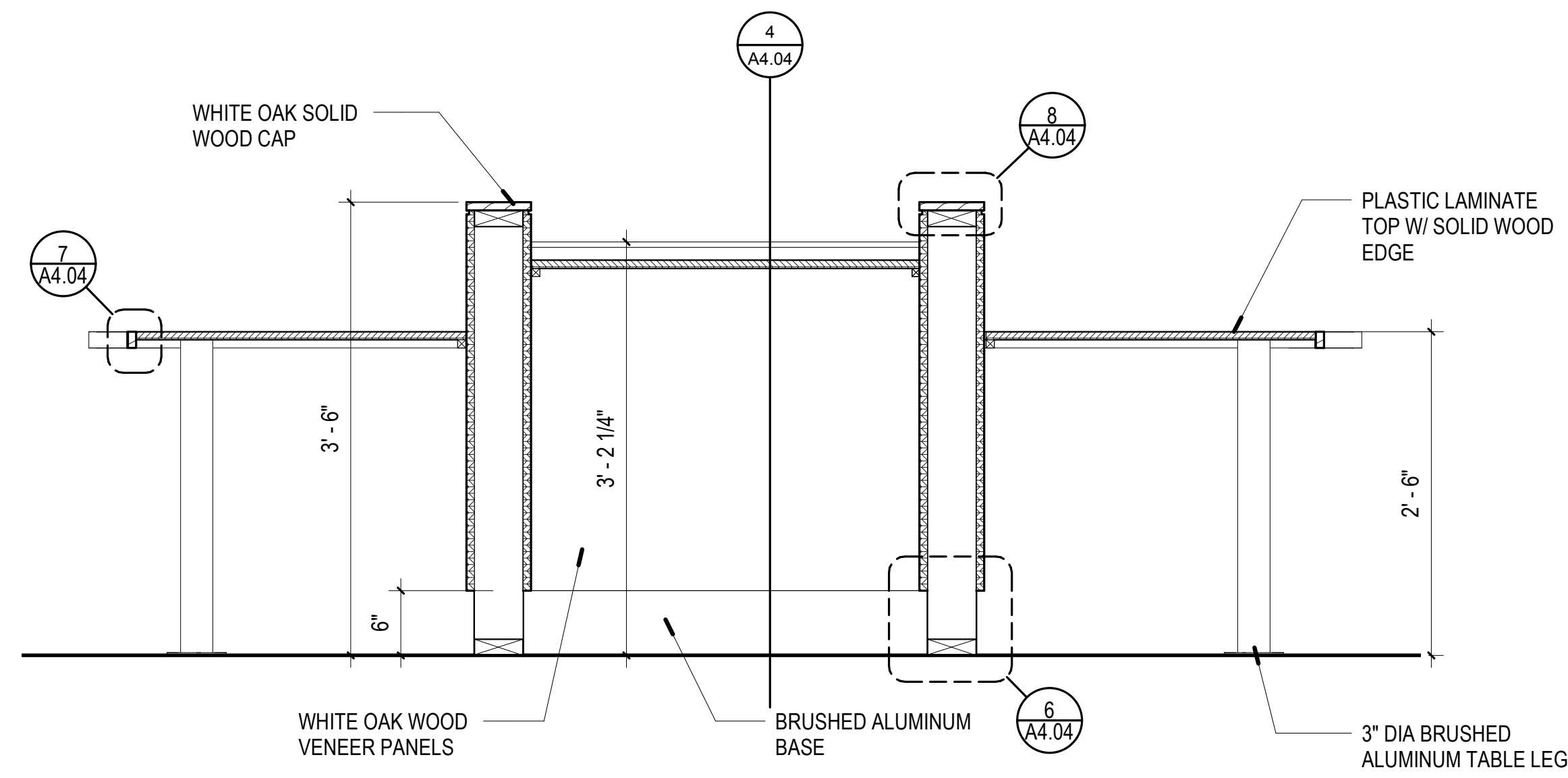

9 SECTION - LECTERN
1" = 1'-0"

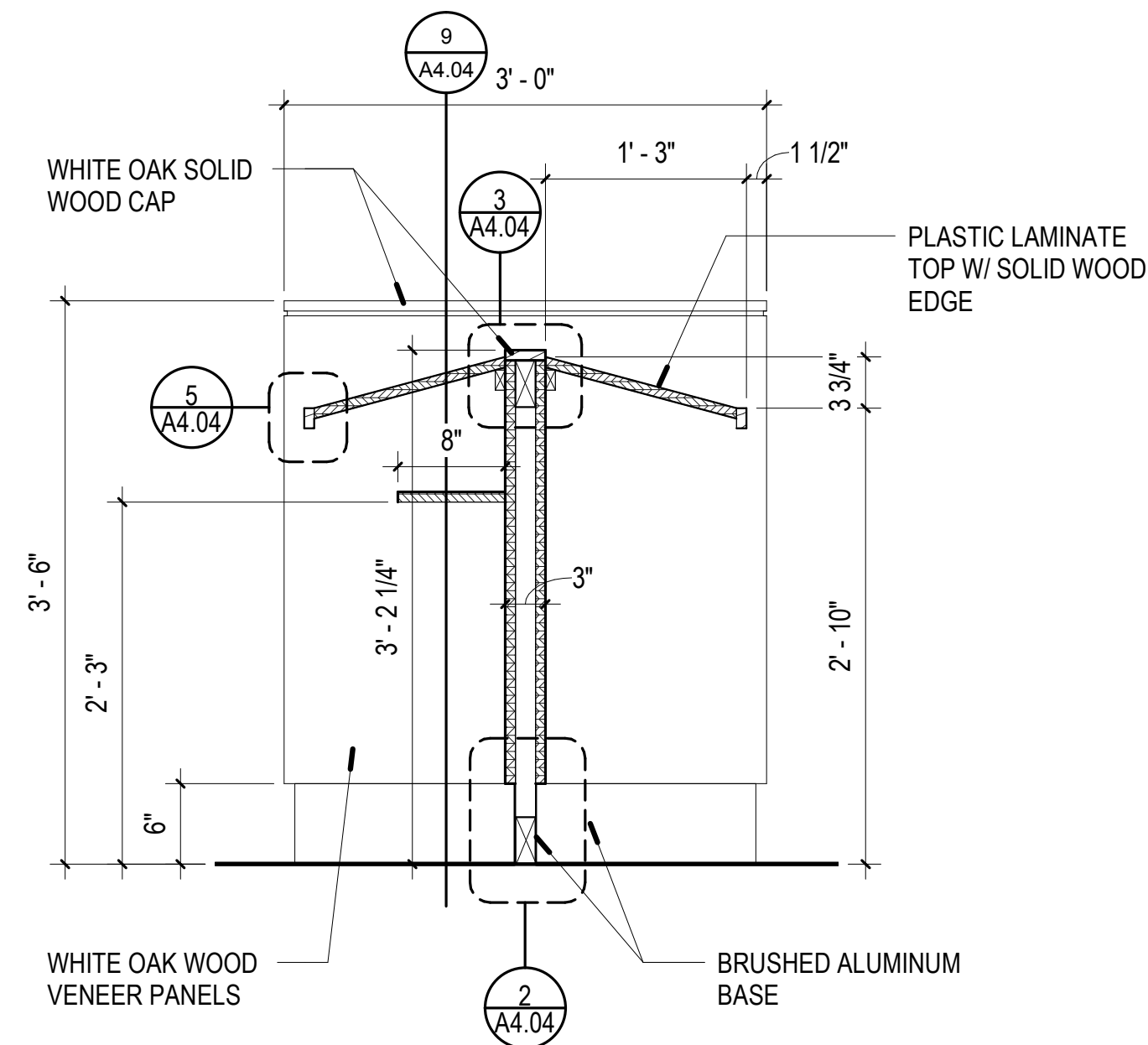

4 SECTION - LECTERN
1" = 1'-0"

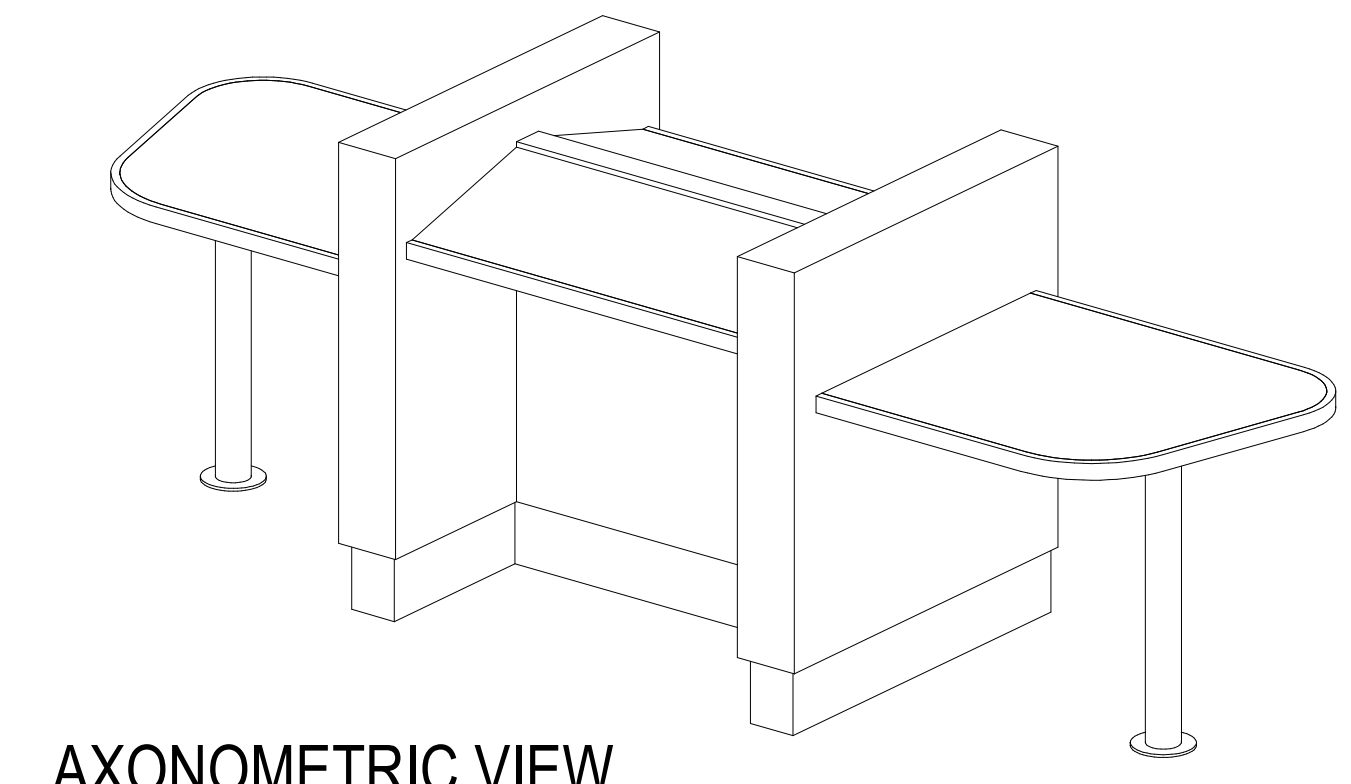

AXONOMETRIC VIEW

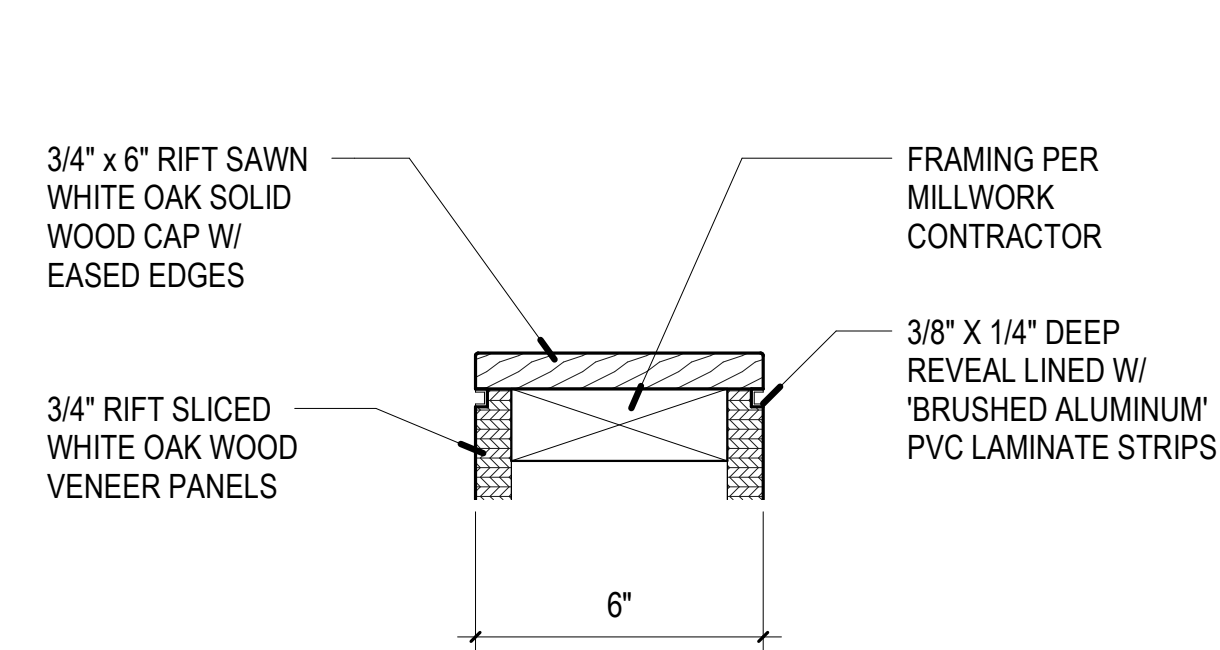

8 LECTERN - TYP WOOD CAP
3" = 1'-0"

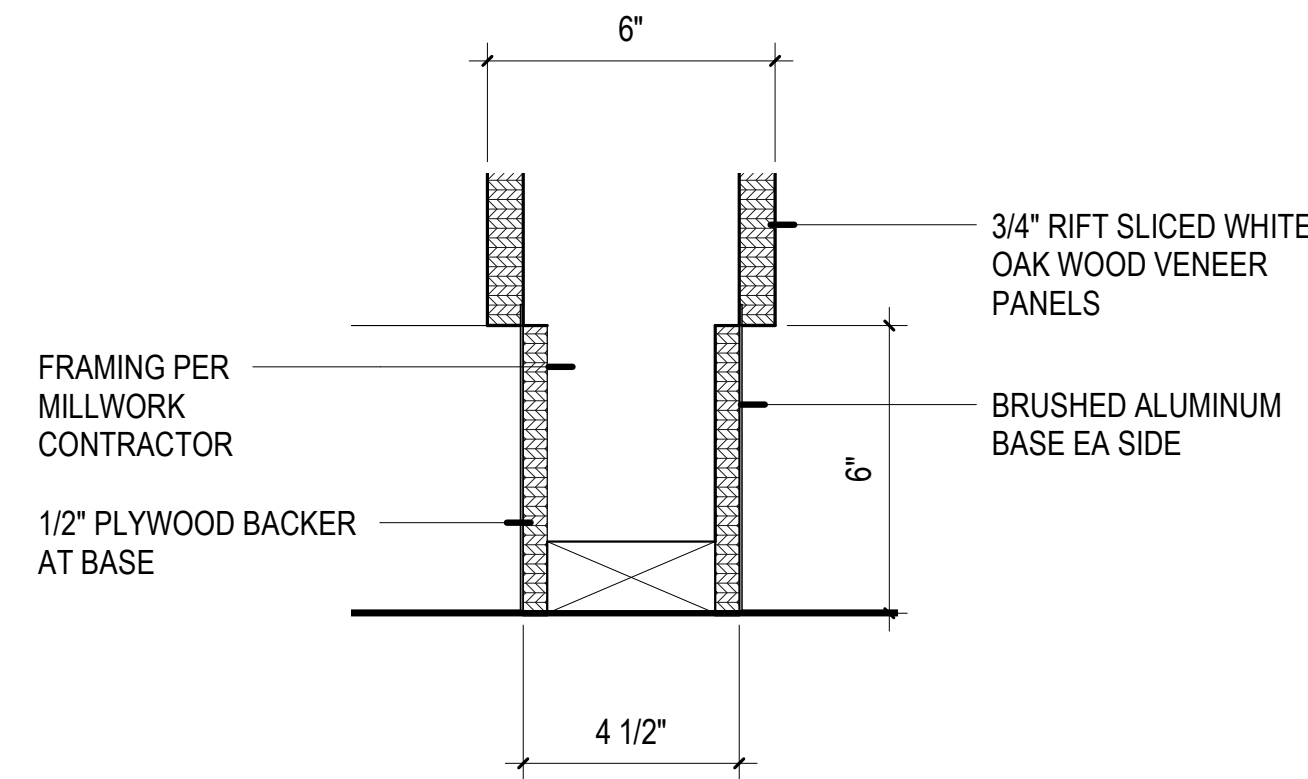

6 LECTERN - TYP BASE
3" = 1'-0"

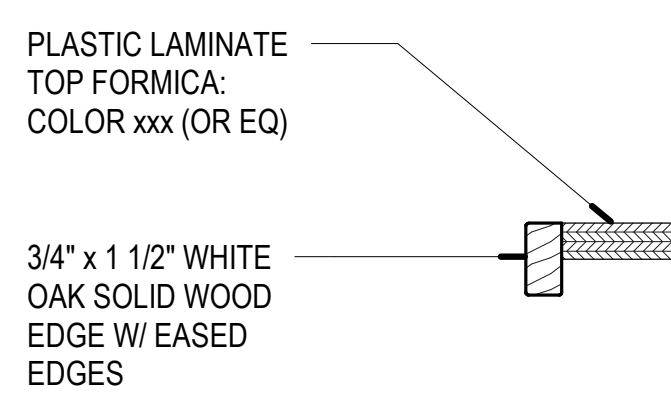

7 TYP COUNTER EDGE DETAIL
3" = 1'-0"

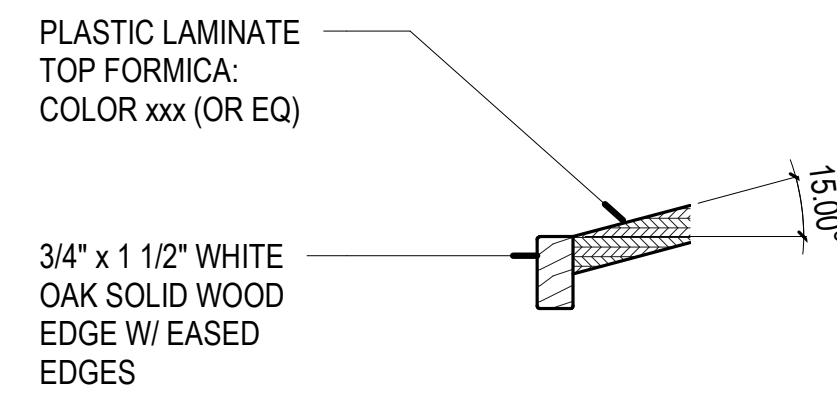

5 LECTERN - TYP EDGE DETAIL
3" = 1'-0"

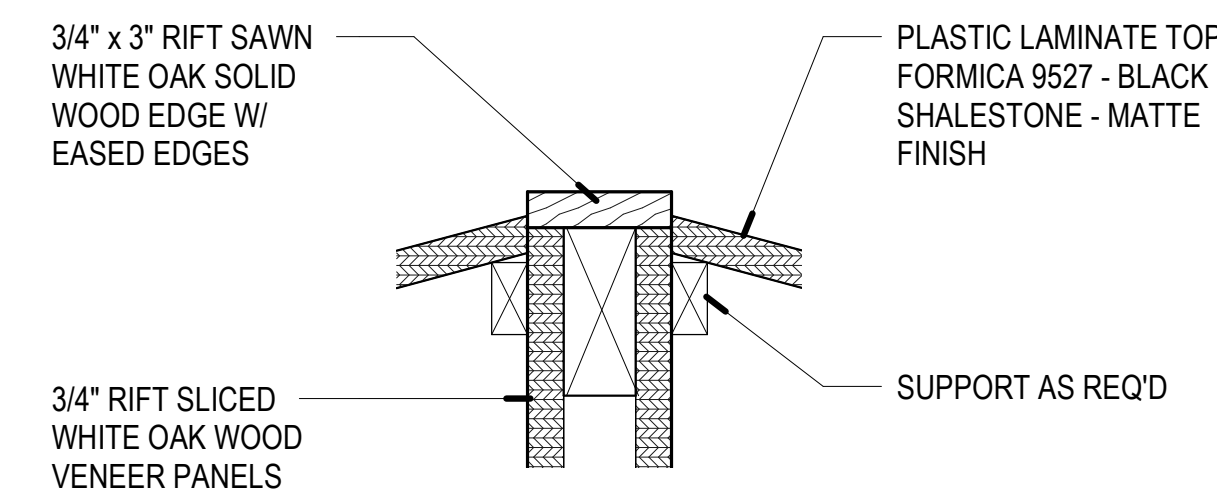

3 LECTERN - WOOD TRANSITION AT TOP
3" = 1'-0"

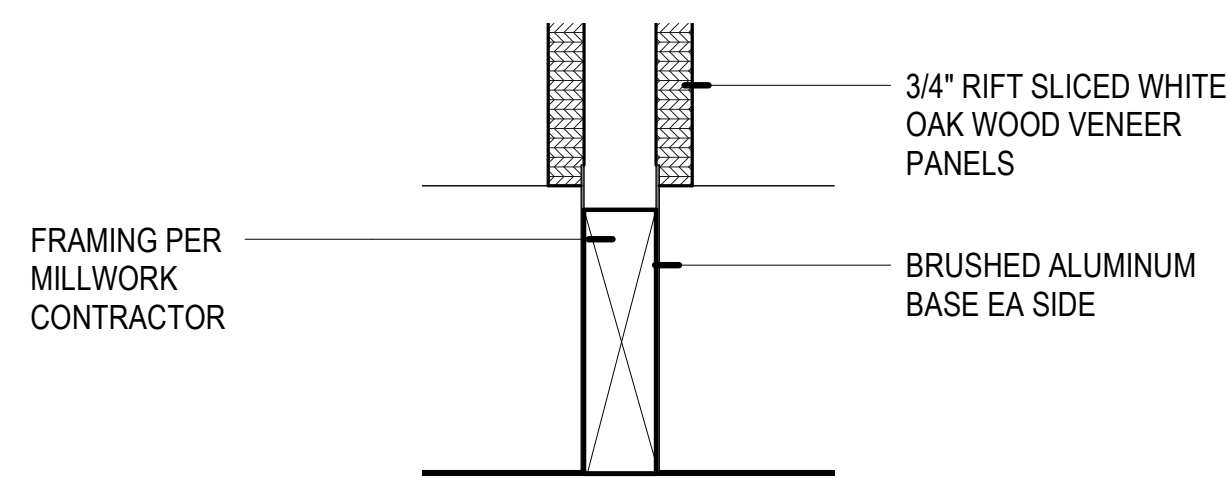

2 LECTERN - TYP CENTER DIVIDER BASE DETAIL
3" = 1'-0"

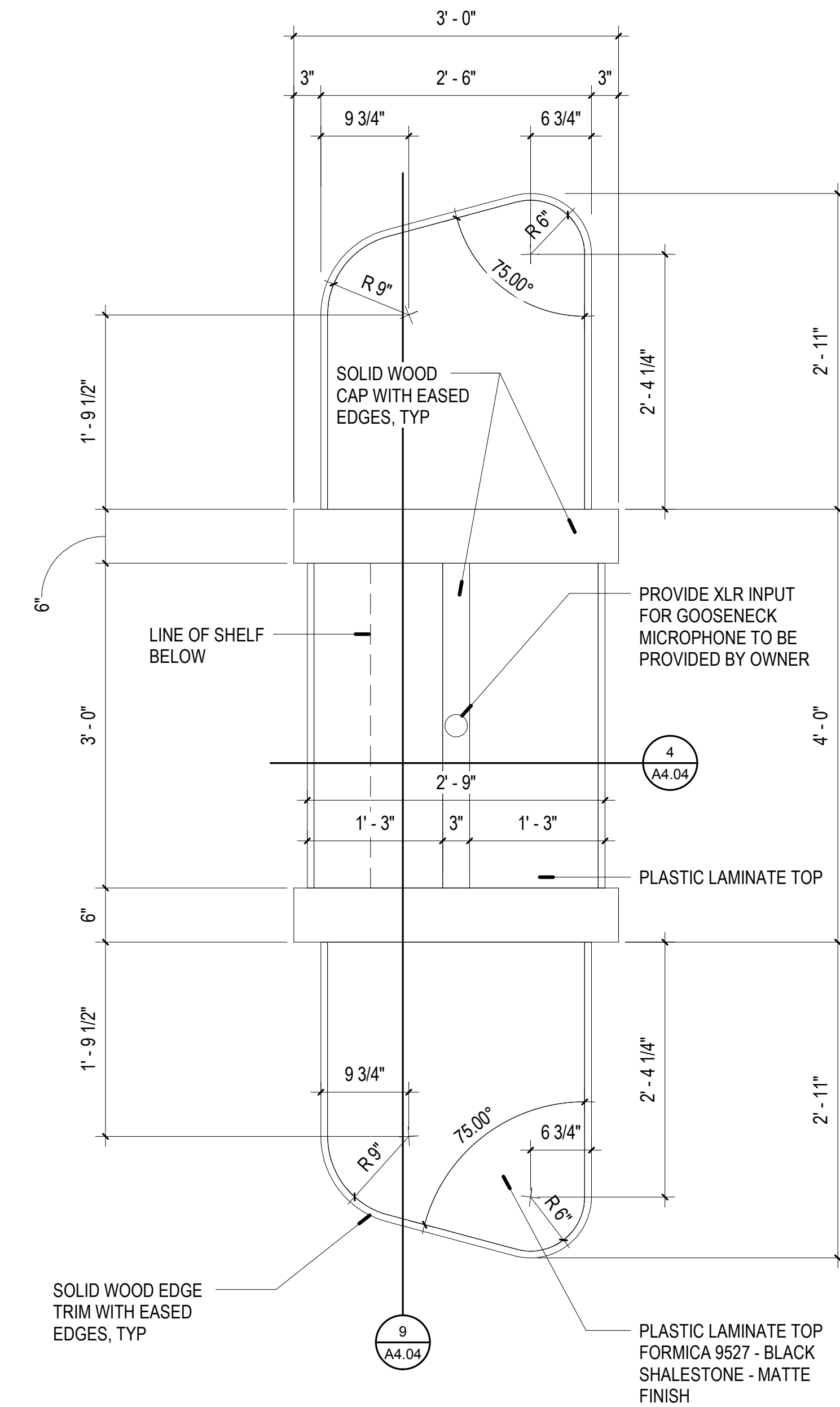

1 FLOOR PLAN - LECTERN
1" = 1'-0"



2050 EAST BARNETT ROAD
PORTLAND, OREGON 97204
503.41.7795
503.41.7728

City of Central Point - Council Chamber Renovation
140 S 3rd Street, Central Point, Oregon 97502
CITY OF CENTRAL POINT
ENLARGED FIXTURE PLAN AND DETAILS - LECTERN

| | | |
|---------|--------------|------|
| PROJECT | 1810 | |
| DATE | JULY 31 2018 | |
| No. | Description | Date |
| | | |
| | | |
| | | |

A4.04

1'-4"
1'
9"
6"
3"
0"
SCALE: 3" = 1'-0"

2'-8"
2'
1'
6"
0"
SCALE: 1 1/2" = 1'-0"

16"
8"
4"
2"
0"
SCALE: 1/4" = 1'-0"

32"
16"
8"
4"
0"
SCALE: 1/8" = 1'-0"

8/2/2018 10:12:36 AM Central File Location Input: Manage -> Settings -> Project Information -> Central File Location

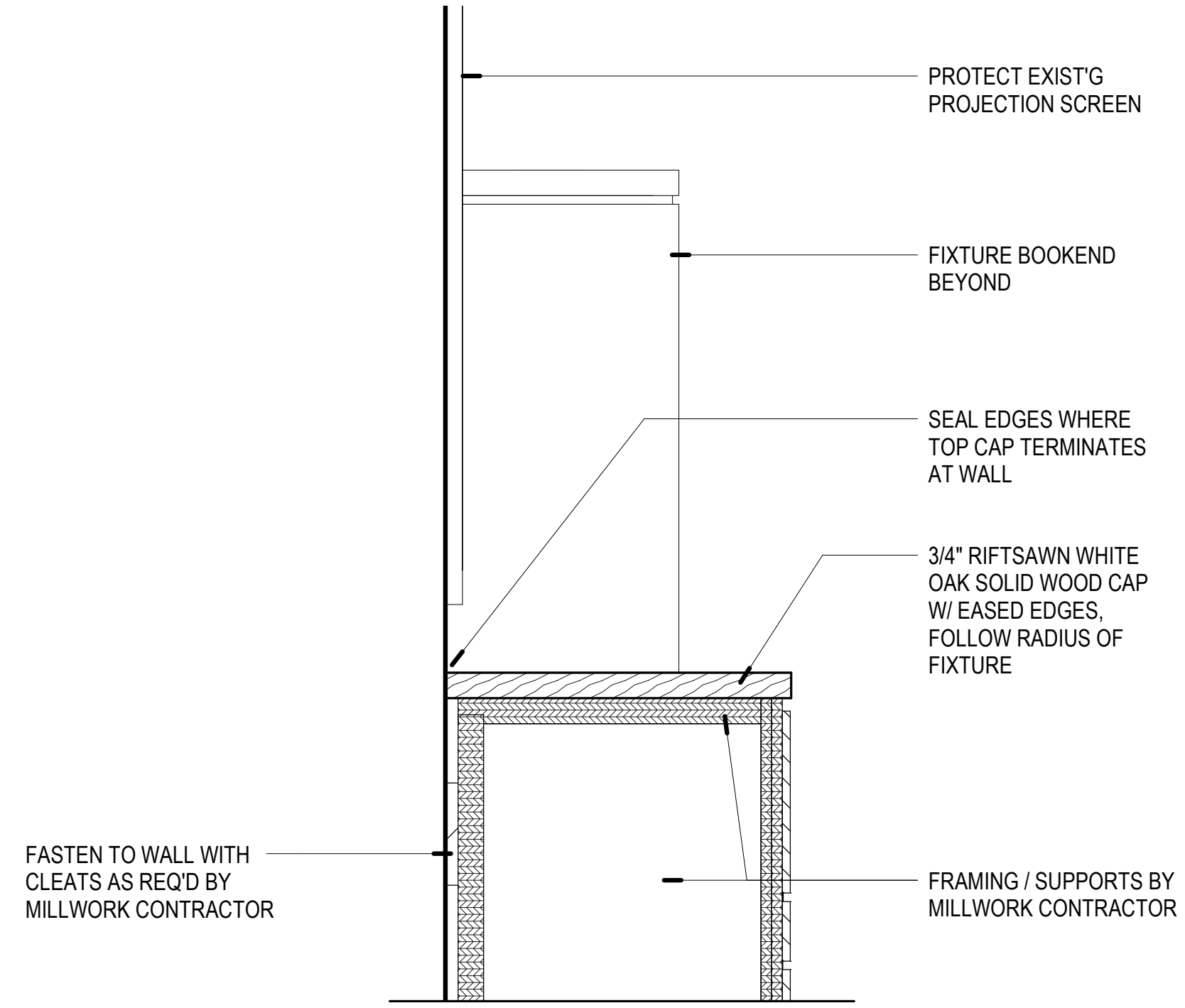

3 SECTION - BACK WALL FIXTURE
3" = 1'-0"

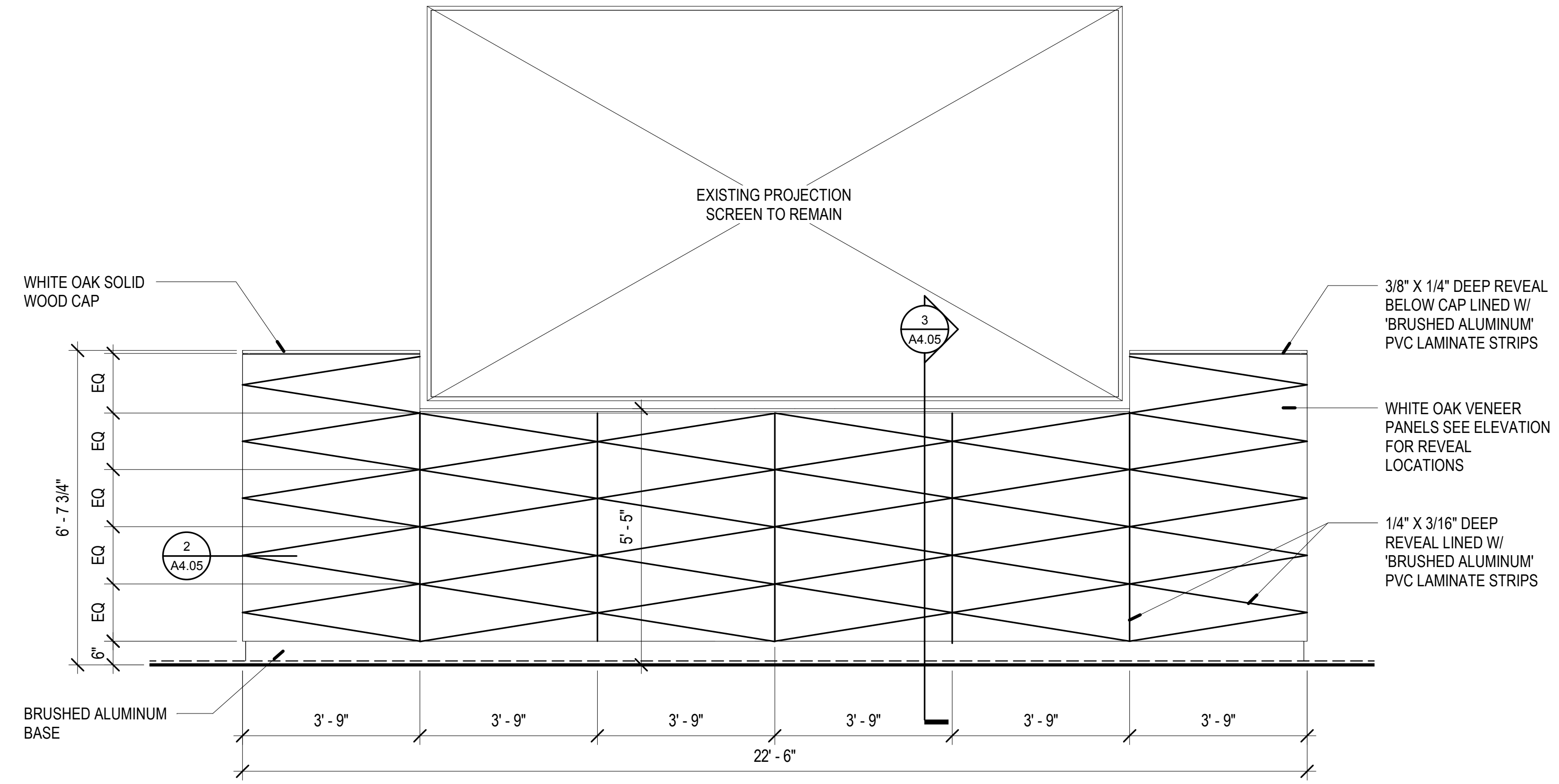
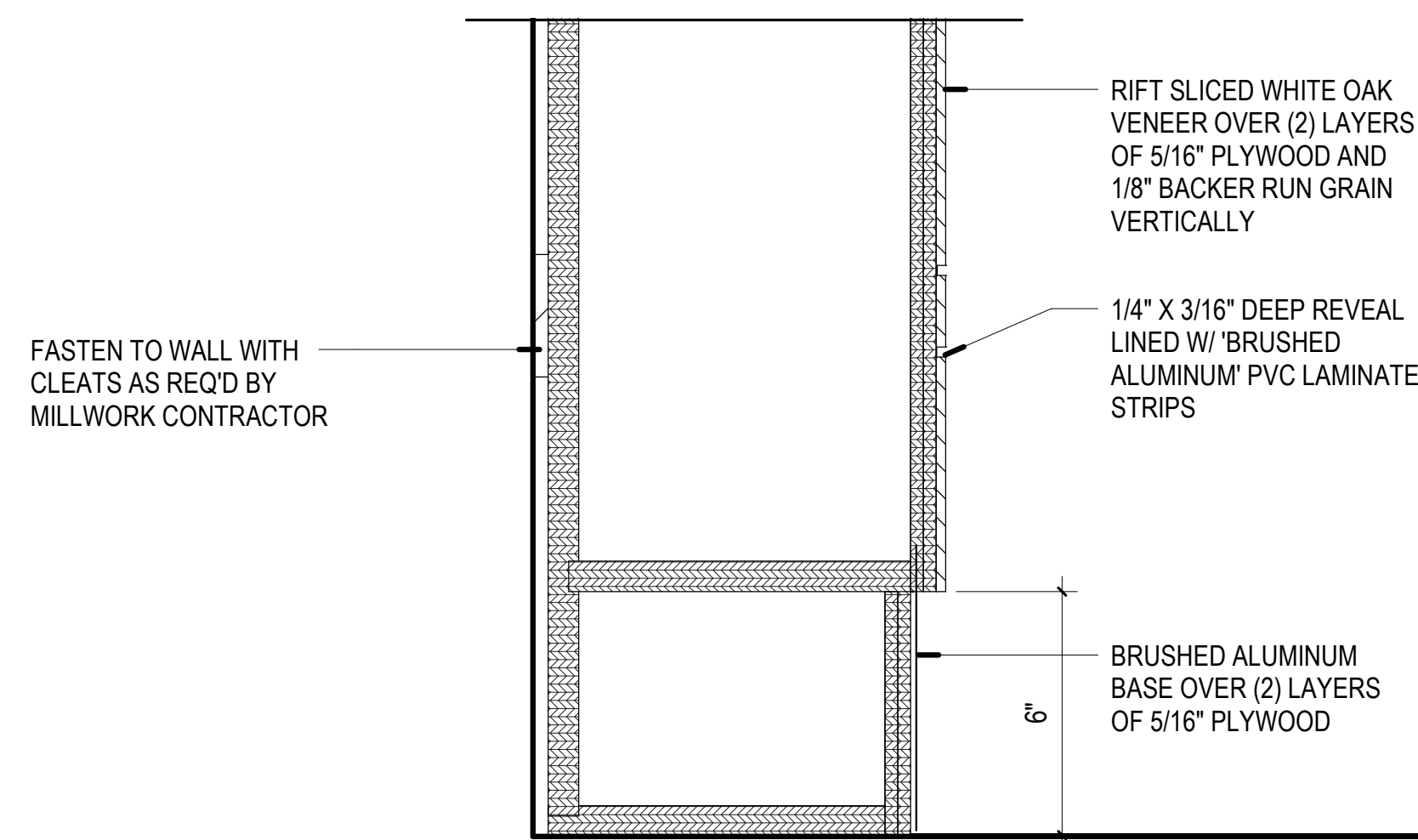

1 ELEVATION - BACK WALL FIXTURE
1/2" = 1'-0"

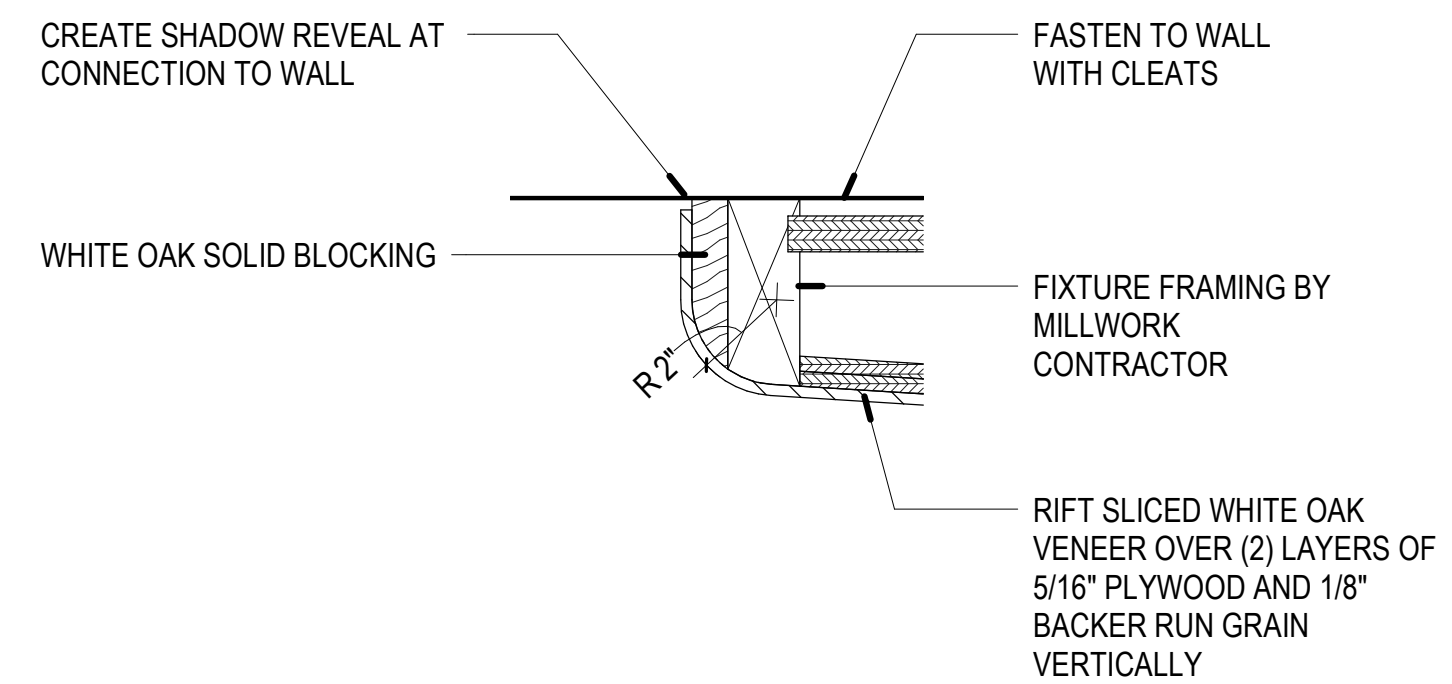

2 DETAIL - BACKWALL FIXTURE TO WALL
3" = 1'-0"

ORW
ALEXANDER WILKERSON
ARCHITECTURE
WWW.ORWARCHITECTURE.COM

2950 EAST BARNETT ROAD
PORTLAND, OREGON 97204
503.417.7799
503.417.7722

City of Central Point - Council Chamber Renovation
140 S 3rd Street, Central Point, Oregon 97502
CITY OF CENTRAL POINT

ENLARGED ELEVATIONS - BACK WALL FIXTURE

| | | |
|---------|--------------|------|
| PROJECT | 1810 | |
| DATE | JULY 31 2018 | |
| No. | Description | Date |
| | | |
| | | |
| | | |

A4.05

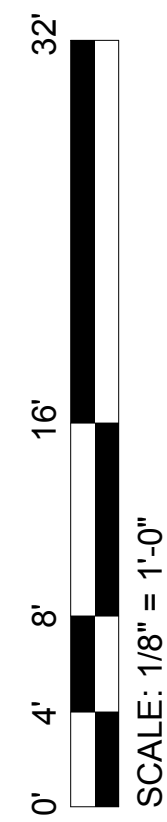
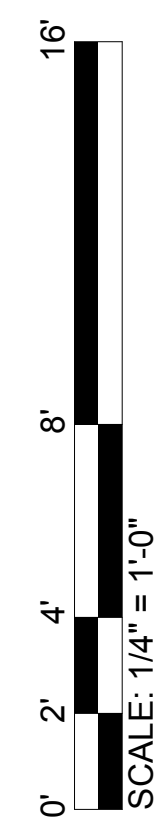
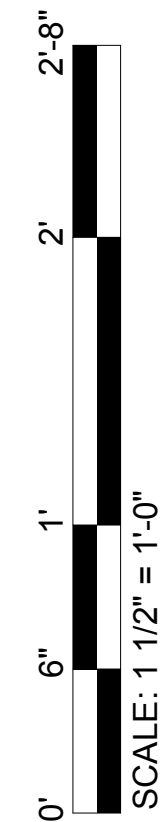
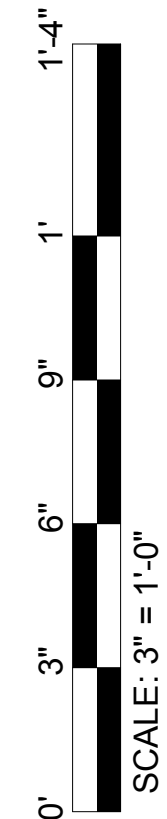

8/2/2018 10:12:44 AM Central File Location Input: Manage -> Settings -> Project Information -> Central File Location

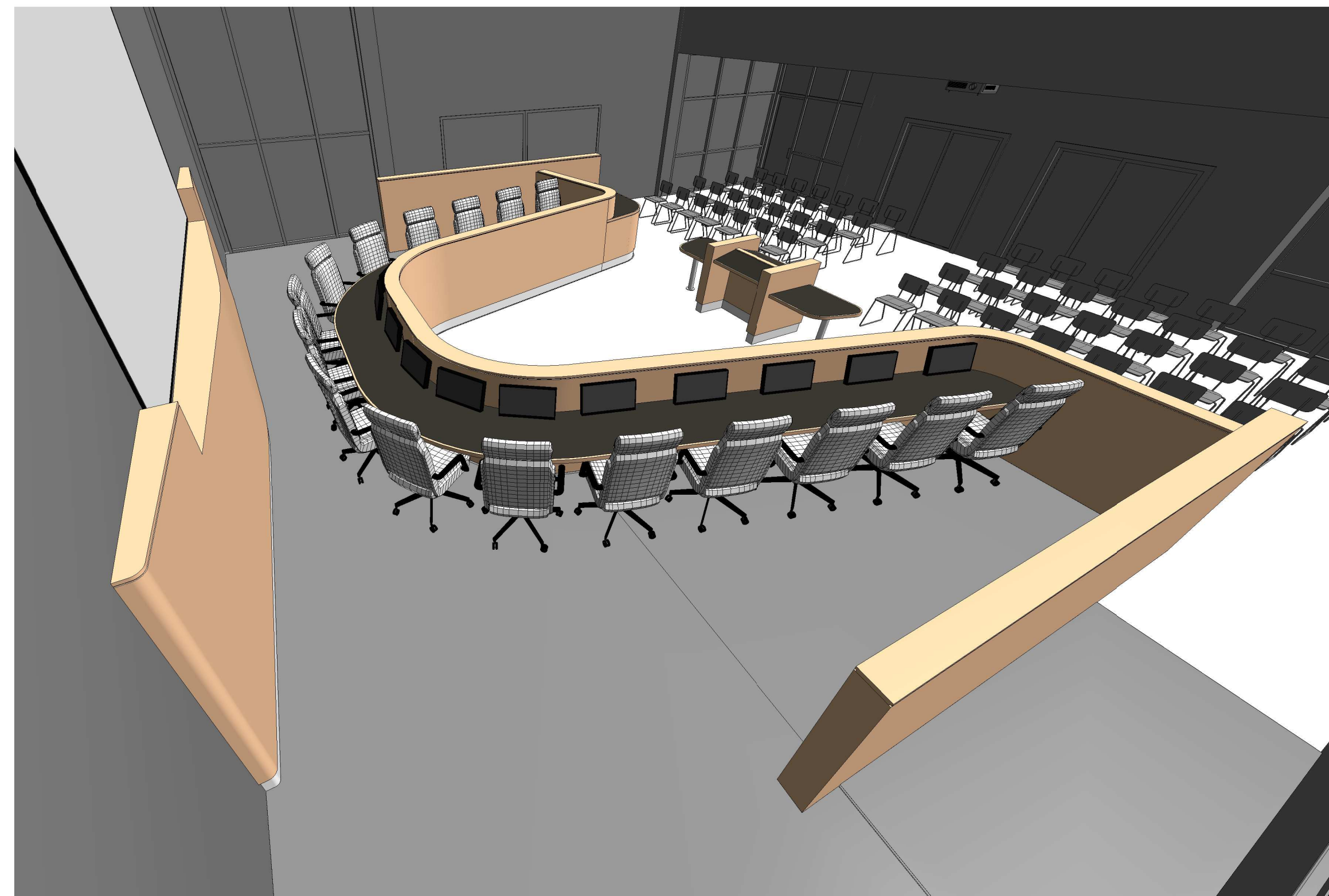

3 PERSPECTIVE VIEW - OVERALL3

NOTE: FOR ILLUSTRATION PURPOSES ONLY. REVEALS AND SURFACE FEATURES OMITTED FOR CLARITY. SEE PLANS, ELEVATIONS, AND DETAILS FOR CONSTRUCTION.



2 PERSPECTIVE VIEW - OVERALL1



1 PERSPECTIVE VIEW - OVERALL2



ORW ARCHITECTURE
2950 EAST BARNETT ROAD
MEDFORD OR 97504
503.779.5257
503.779.8478

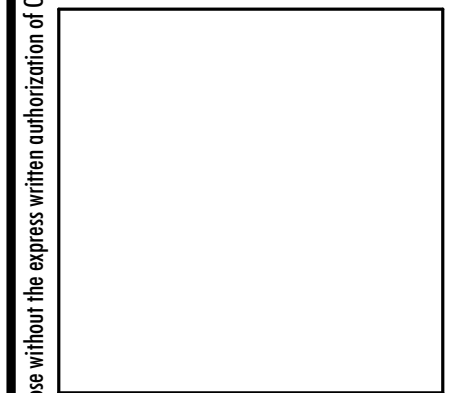

City of Central Point - Council Chamber Renovation
140 S 3rd Street, Central Point, Oregon 97502
CITY OF CENTRAL POINT
PERSPECTIVE VIEWS

| | | |
|---------|--------------|------|
| PROJECT | 1810 | |
| DATE | JULY 31 2018 | |
| No. | Description | Date |
| | | |
| | | |
| | | |

A4.06



**CITY OF CENTRAL POINT
PUBLIC IMPROVEMENT CONTRACT**

**PROJECT:
Council Chambers Renovation**

THIS CONTRACT, made and entered into this _____ day of _____, 20__ ,
by and between the City of Central Point, a municipal corporation of the State of Oregon,
hereinafter called "City" and Outlier Construction, LLC hereinafter called "Contractor", duly
authorized to perform such services in Oregon.

Contractor Information

Address: 841 O'Hare Parkway, Ste. 100, Medford, OR 97504 Phone: 541-622-2043
Fax: 541-494-0038 Contact: Rob Mayers Email:
CCB No.: 217660 Fed ID #

Recital

City of Central Point selected Contractor to perform work for the City by a competitive bid process. Contractor submitted the lowest qualified bid for the Project.

WHEREAS, City requires construction and related services which Contractor is capable of providing, under terms and conditions hereinafter described; and

WHEREAS, time is of the essence in this contract and all work under this contract shall be completed within the time period stated in the Bid;

TERMS & CONDITIONS OF CONTRACT

Term – Duration of Contract

This Contract shall be effective when signed by both parties and Contractor has submitted the required certificates of insurance and performance and payment bonds. It shall remain in effect until the work on the Project has been completed, the improvement accepted by the City, and the warranty period has expired. The expiration of the term does not affect any right that arose prior to expiration, and terms that by their nature survive expiration shall remain in effect after expiration.

- Work shall commence on September 16, 2019
- Work shall be substantially complete by October 9, 2018

Attachment: Council Chambers Renovation Contract (1157 : City Council Chambers Renovation Project Contract Approval)

Scope of Work

Contractor shall construct COUNCIL CHAMBERS RENOVATION (the "Project"). The Project is described in more detail in the attached Contractor's Proposal "Exhibit A" and as detailed in the City's Special Provisions, Standard Specifications and Drawings for this Project. Contractor hereby agrees to furnish all of the materials, labor, water, tools, equipment, light, power, transportation, and other work needed to construct the Project, unless otherwise stated. Collectively all documents herein, plans, referenced laws, statutes, codes, procedures, material specifications, and schedules are applicable to the scope of Work.

Payment

City shall pay Contractor according to the schedules and unit prices as quoted by Contractor "Exhibit A". The maximum total payment under this Contract without approved written change orders is \$149,006.00.

Application for Payment

Contractor shall invoice the City monthly for work performed, based on an estimate of the amount of work completed and the value of the completed work. Contractor will direct the application for payment or invoice to the City of Central Point, Attention: Derek Zwagerman, Building Official, 140 South Third Street, Central Point OR 97502. City shall make progress payment equal to the value of the completed work, less amounts previously paid, less retainage of five percent, less any deduction for claims and damages paid by the City of Central Point due to acts or omissions of the Contractor and for which he/she is liable under this Contract within 15 days of receipt of the invoice and the prevailing wage certificates certifying that he/she has paid not less than the prevailing rate of wages as required by ORS 279C.840. The form/application for payment shall be acceptable to the City of Central Point.

Application Free of Encumbrances

Contractor warrants and guarantees that all work, materials and equipment covered by any application for payment, will pass to City of Central Point at the time of payment free and clear of liens, claims, security interests and encumbrances.

City Review & Approval of Application for Payment

The City will, after receipt of each application for payment, either indicate in writing his/her approval of payment and present the application to the City of Central Point, or return the application to Contractor indicating in writing his/her reasons for refusing to approve payment. In the latter case, Contractor may make the necessary corrections and resubmit for application.

Payment on Estimated Quantities

Nothing contained in this contract shall be construed to affect the right, hereby reserved, to reject the whole or any part of the aforesaid work should such work be later found not to comply with any of the provisions of this Contract document. All estimated quantities of work for which progress payments have been made are subject to review and correction on the final estimate. Acceptance by the Contractor of progress payments based on periodic estimates of quantities of work shall not, in any way, constitute acceptance of the estimated quantities used as the basis for computing the amounts of the progress payments.

Final Payment

Final payment shall be made in accordance with Section 012000 Price and Payment of the Standard Specifications.

Adherence to Law

Contractor shall adhere to all applicable laws, governing its relationship with its employees, including but not limited to laws, rules, regulations, and policies concerning workers' compensation, and minimum and prevailing wage requirements. When multiple standards apply, Contractor shall comply with the more stringent standard. Specifically but not by way of limitation, this contract is subject to all applicable provisions of ORS 279C.505, 279C.510, 279C.515, 279C.520, 279C.525, 279C.530, 279C.540, 279C.570, 279C.580, and 279C.800- 279C.870.

To the extent applicable, Contractor represents that it will comply with Executive Order 11246 as amended, Executive Order 11141, Title VI of the Civil Rights Act of 1964, Section 503 of the Vocational Rehabilitation Act of 1973 as amended, the Age Discrimination Act of 1975, and all rules and regulations issued pursuant to the Acts. Contractor also shall comply with the Americans with Disabilities Act of 1990 (Pub L No. 101-336), ORS 659.425, and all regulations and administrative rules established pursuant to those laws. Contractor agrees to comply with ADA in its employment practices, and that it shall perform its contractual obligations consistently with ADA requirements and regulations, state law, and applicable regulations.

Environmental

Contractor shall comply with federal, state and local agencies ordinances, rules and regulations dealing with the prevention of environmental pollution and the preservation of natural resources that affect the performance of the Contract. The City reserves the right if environmental requirements (either new or existing ordinances) must be met after the award of the Contract, City, in accordance with ORS 279C.525, may (a) Terminate the Contract; (b) Complete the work itself; (c) Use non-City forces already under contract with the City; (d) Require that the underlying property owner be responsible for cleanup; (e) Solicit bids for a new Contractor; and (f) Issue the awarded Contractor a change order setting forth the additional work that must be undertaken. In addition, (a) City must make known environmental conditions at the construction site that may require Contractor to comply with environmental ordinances in their bid documents; (b) If not known at the time of award, Contractor shall immediately give notice of the discovered environmental condition to the City; (c) If an environmental emergency exists, City & Contractor shall follow the rules (4), (5), (6), (7) & (8) under ORS 279C.525. If the City chooses to terminate the contract under this subsection, Contractor, if no negligence or omission on his/her part, shall be entitled to all costs and expenses incurred to the date of termination, including overhead and reasonable profits, on the percentage of work completed. If City causes work to be done by another entity, Contractor may not be held liable for actions or omissions of the other entity.

Oregon State Public Contract Provisions**Contractor Shall:**

- Make payment promptly, as due to all persons supplying to the contractor labor or material for the performance of the work provided for the Contract.
- Pay all contributions or amounts due the Industrial Accident Fund from the Contractor or Subcontractor incurred in the Contract.
- Not permit any lien or claim to be filed or prosecuted against the City.
- Pay to the Department of Revenue all sums withheld from employees under ORS 316.167.
- Demonstrate that an employee drug testing program is in place. City has the right to audit and/or monitor the program. On request by the City, Contractor shall furnish a copy of the employee drug-testing program.
- Salvage or recycle construction and demolition debris, if feasible and cost-effective.

Prompt Payment/Contractor Refusal to Make Payment:

- If Contractor fails, neglects or refuses to make prompt payment of any claim for labor or services furnished to the Contractor or a Subcontractor by any person in connection with the public improvement contract as the claim becomes due, the City may pay the claim to the person furnishing the labor or services and charge the amount of the payment against funds due or to become due the Contractor by reason of the contract.
- If Contractor or first-tier Subcontractor fails, neglects or refuses to make payment to a person furnishing labor or materials in connection with this contract within 30 days after receipt of payment from the City (or in a case of Subcontractor, from Contractor), Contractor or first-tier Subcontractor shall owe the person the amount due plus interest charges commencing at the end of the 10-day period that payment is due under ORS 279C.580 (4) and ending upon final payment, unless payment is subject to a good faith dispute as defined in ORS 279C.580. The rate of interest charged to the Contractor or first-tier Subcontractor on the amount due shall equal three times the discount rate on 90-day commercial paper in effect at the Federal Reserve Bank in the Federal Reserve district that includes Oregon on the date that is 30 days after the date when payment was received from the contracting agency or from the Contractor, but the rate of interest may not exceed 30 percent. The amount of interest may not be waived.
- If Contractor or a Subcontractor fails, neglects or refuses to make payment to a person furnishing labor or material in connection with, the person may file a complaint with the Construction Contractor Board (CCB), unless payment is subject to a good faith dispute as defined in ORS 279C.580.
- The payment of a claim in the manner authorized in this section does not relieve the Contractor or the Contractor's surety from obligation with respect to any unpaid claims.

Hours of Labor – Posting Hours of Labor:

- For work under this contract, a person may not be employed for more than 10 hours in any one day, or 40 hours of work in any one week, except in cases of necessity, emergency or when the public policy absolutely requires it, and in those cases, the employee shall be paid at least time and a half pay:
 - a. For all overtime in excess of eight hours in any one day or 40 hours in any one week when the work week is five consecutive days, Monday through Friday; and
 - b. For all overtime in excess of 10 hours in any one day or 40 hours in any one week when the work week is four (4) consecutive days, Monday through Friday; and
 - c. For all overtime in excess of 10 hours in any one day or 40 hours in any one week when the work week is four consecutive days, Monday through Friday; and
 - d. For all work performed on Saturday and on any legal holiday specified in ORS 279C.540.
- Contractor is not required to pay overtime if the request for overtime pay is not filed within 30 days of completion of the Contract if Contractor has posted and maintained in place a circular with the information contained in ORS 279C.545 as required by ORS 279C.545(1).
- Contractors and Subcontractors must give notice in writing to employees who perform work under this contract, either at the time of hire or before commencement of work on the contract, or by posting a notice in a location frequented by employees, of the number of hours per day and days per week that the employees may be required to work.

Medical Coverage to Employees:

- Contractor shall promptly, as due, make payment to any person, co-partnership, association or corporation furnishing medical, surgical and hospital care services or other needed care and attention, incident to sickness or injury, to the employees of Contractor, of all sums that Contractor agrees to pay for the services and all moneys and sums that the Contractor collected or deducted from the wages of employees under any law, contract or agreement for the purpose of providing or paying for the services.

Worker's Compensation:

- All employers, including Contractor, that employ subject workers who work under this Contract in the State of Oregon shall comply with ORS 656.017 and provide the required Workers' Compensation coverage, unless exempt under ORS 656.126. Contractor shall insure that each of its Subcontractors comply with these requirements.

Obligation to Pay Subcontractor & Suppliers within 10 Days:

- Contractor shall include in each first-tier subcontract, including contracts with material suppliers, a clause that obligates Contractor to pay the first-tier Subcontractor for satisfactory performance under its subcontract within 10 days out of the amounts paid to Contractor by City under this contract, and if payment is not made within 30 days after receipt of payment from City, to pay an interest penalty as specified in ORS 279C.515(2) to the first-tier Subcontractor. The interest penalty does not apply if the only reason the delay in payment is due to a delay in payment by City to Contractor. Contractor shall include in each of Contractor's subcontracts, a provision requiring the first-tier Subcontractor to include a similar payment and interest penalty clause and shall require Subcontractors to include similar clauses with each lower-tier Subcontractor or supplier.

Certifications:

- By signing the Contract, Contractor will certify that all Subcontractors performing construction work will be registered by the Construction Contractors Board (CCB) or licensed by the State Landscape Contractors Board before the Subcontractor starts work on the Project.
- By signing the Contract, Contractor will certify that it will comply with Oregon tax laws. In addition: Contractor will be solely responsible for payment of any federal or state taxes required as a result of this Contract/Agreement.

Indemnity – Hold Harmless

Contractor shall defend, indemnify, and hold the City, its officers, agents and employees, harmless against all liability, loss, or expenses, including attorney's fees, and against all claims, actions or judgments based upon or arising out of damage or injury (including death) to persons or property caused by or resulting from any act or omission sustained in connection with the performance of the Contract/Agreement or by conditions created thereby, or based upon violation of any statute, ordinance or regulation.

Insurance: Contractor and its subcontractors shall maintain insurance acceptable to City in full force and effect throughout the term of contract. Such insurance shall cover all risks arising directly or indirectly out of Contractor's activities or work hereunder, including the operations of its subcontractors of any tier. Such insurance shall include provisions that such insurance is primary insurance with respect to the interests of the City and that any other insurance maintained by City is excess and not contributory insurance with the insurance required hereunder.

General Liability

- Contractor shall purchase and maintain commercial general liability insurance with minimum coverage of \$1 million per occurrence and \$2 million aggregate. The policy shall name the City as an additional insured and cover acts and omissions of Contractor and its Subcontractors of any level. Contractor shall be liable for the full amount of any claims resulting from negligence or intentional misconduct of Contractor, its subcontractors, and their officials, agents and employees in the performance of this Contract, even if not covered by or in excess of insurance..

Workers Compensation

- Workers compensation insurance as required by ORS Chapter 656. Contractor shall ensure that each subcontractor obtains workers compensation insurance. The Contractor shall ensure that its insurance carrier files a guaranty contract with the Oregon Workers' Compensation Division before performing Work. In addition, Section "Oregon State Public Contract Provisions" – subsection "Workers' Compensation" and section "Independent Contractor – Non-Partnership" of this Contract is applicable.

Builder's Risk

- Contractor shall provide builder's risk insurance on an all risks of direct physical loss basis, including, without limitation, earthquake and flood damage, for amount equal to at least the value of the amount installed. Any deductible shall not exceed \$50,000 for each loss, except that the earthquake and flood deductible shall not exceed 5% of each loss or \$50,000, whichever is greater. The policy shall include the City of Central Point as loss payee. In addition, Section 00170.70 (g) Builders Risk of the Standard Specifications is applicable to this Contract.

Automobile Insurance

- If required, the combined single limit per occurrence shall be in an amount at least equal to the State/DMV requirements. In addition, Section 00170.70 Insurance of the Standard Specifications is applicable to this Contract.

Insurance Carrier Rating

- Coverage provided by the Contractor must be underwritten by an insurance company deemed acceptable by City. City reserves the right to reject all or any insurance carrier(s) with an unacceptable financial rating.

Cross-Liability Clause

- A cross-liability clause or separation of insureds clause will be included in general liability policy. Contractor's insurance policy shall contain provisions that such policies shall not be canceled or their limits of liability reduced without thirty (30) days prior notice to City. A copy of each insurance policy, certified as a true copy by an authorized representative of the issuing insurance company, or at the discretion of City, in lieu thereof, a certificate in form satisfactory to City certifying to the issuance of such insurance shall be forwarded to the Public Works Director. Such policies or certificates must be delivered prior to commencement of the work. Thirty (30) days cancellation notice shall be provided City by certified mail to the Public Works Director in the event of cancellation or non-renewal of the insurance. The procuring of such required insurance shall not be construed to limit contractor's liability hereunder. Notwithstanding said insurance, Contractor shall be obligated for the total amount of any damage, injury, or loss caused by negligence or neglect connected with this contract.

Bonds**Payment and Performance Bonds**

- Contractor shall provide a separate Performance Bond and a separate Payment bond in a form acceptable to the City of Central Point. Each bond shall be equal to 100% of the Contract amount. The Performance Bond and Payment Bond must be signed by the Surety's Attorney-in-fact, and the Surety's seal must be affixed to each bond. Bonds shall not be canceled without the City of Central Point's consent, nor will the City release them prior to Contract completion. Bonds must be originals – faxed or photocopied bond forms will not be accepted.

Public Works Bond

- Contractor will file with the Construction Contractors Board (CCB) a Public Works Bond with a corporate surety authorized to do business in the State of Oregon in the amount of \$30,000 prior to starting work on this contract. Contractor is aware of the provisions of ORS 279C.600 and 279C.605 relating to notices of claim and payment of claims on public works bonds.

Conflict of Interest

Contractor shall not give or offer any gift, loan, or other thing of value to any City official or employee. The Contractor shall not rent, lease, or purchase materials, supplies, or equipment, with or through any City official or employee.

Impact on Traffic and Property

Contractor shall adopt reasonable means and comply with all laws, ordinances, and regulation in order to minimize interference to traffic and damage to both public and private property; And in accordance to the Standard Specifications, shall provide a traffic plan, maintain two-way traffic unless approved otherwise by the City of Central Point, and make every effort to maintain public safety and convenience. Contractor shall provide adequate noise control and shall control all obstructions to traffic in accordance with the manual on uniform traffic control devices if applicable.

Prevailing Wage**Basic Requirement**

- In accordance to ORS 279C.840, Contractor shall pay to workers in each trade or occupation the current, applicable State prevailing rate of wage as established by the Oregon State Bureau of Labor and Industries (BOLI). The wage rates applicable are those in effect at the time Project was first advertised.

Posting of Prevailing Wage Rates

- Contractor, Subcontractor shall post the prevailing wage rates and fringe benefits in the locality where the labor is performed.

Certifications of Wage Rates to City of Central Point

- Contractor shall furnish weekly to the City of Central Point certified statements, in writing on a form prescribed by the Commissioner of the Bureau of Labor, certifying: (a) The hourly rate of wage paid each worker whom the Contractor or Subcontractor has employed upon the public works improvement; and (b) That no worker employed upon the public works has been paid less than the prevailing rate of wage or less than the minimum hourly rate of wage specified in the Contract.

- If the Contractor has not filed the certified statements as required under this contract, The City of Central Point is required by law to retain 25% of any amount earned by the Contractor until the Contractor has complied. Final payment cannot be made without all applicable wage rates on file with the City.

Access to Wage Rate Records – Worker Interview Verification

- Contractor shall allow the Bureau of Labor and Industries (or Federal Officials) to enter the office or business establishment of Contractor at any reasonable time to determine whether the prevailing rate of wage and or the higher of the State prevailing wage rate and the Davis-Bacon wage rate is actually being paid and shall make payment records available to BOLI or Federal Officials on request. Contractor shall require Subcontractors to provide the same right of entry and inspection. In addition, shall allow interviews with persons with each discipline (trade) to determine if the correct wage rate is actually being paid.

All BOLI Requirements Applicable

- Contractor must comply with all laws and regulations relating to prevailing wages, whether or not set out in this Contract. Further information regarding prevailing wages, including requirements applicable to Contractor, is available at: <http://www.oregon.gov/BOLI/WHD/PWR/index.shtml>. And available by contacting the Bureau of Labor & Industries at 971-673-0839

Warranties

All work shall be guaranteed for a period of one (1) year against defects in materials and workmanship. Contractor unconditionally warrants all work and materials for this Project, including additional work authorized under change orders, against any defects whatsoever, for one (1) year from the date of acceptance by the City of Central Point, except that manufacturers' warranties and extended manufacturer warranties as specified in the contract documents or otherwise is a standard manufacturer product warranty shall not be abridged. In addition to its right to proceed on the warranty, the City may recover for breach of contract or negligence even if defects do not become evident during the warranty period. The Contractor also agrees to hold the City of Central Point harmless from claims of any kind arising from damage due to said defects.

Liquidated Damages

The City of Central Point is authorized to deduct the amount of the liquidated damages from any amounts due and the Contractor and its Surety shall be liable for any excess. If the Contract is terminated for default (see following "Termination") and if the Work has not been completed by other means on or before the expiration of Contract time or adjusted Contract time, liquidated damages will be assessed against the Contractor for the duration of time reasonably required to complete the work. Contractor and City agree that a reasonable amount of damages for late completion is \$100 per calendar day after October 9, 2019 and Contractor agrees to pay such amounts as liquidated damages if the work is not completed by October 23, 2019. Contractor agrees that the liquidated damages specified herein are a fair way of ascertaining damages to the City and are not a penalty for late completion.

Termination of Contract and Substituted Performance

Termination for Default – Termination of the Contract for default may result if the Contractor:

- Violates any material provision of the Contract;
- Disregards applicable laws and regulations or the City's instructions;
- Refuses or fails to supply enough materials, equipment or skilled workers for the prosecution of the Work in compliance to the Contract;
- Fails to make prompt payment to Subcontractors;
- Makes an unauthorized general assignment for the benefit of the Contractor's creditors;
- Has a receiver appointed because of the Contractor's insolvency;
- Fails to maintain reasonable relations with the public. Verbal abuse, threats, or other inappropriate behavior towards members of the public constitutes grounds for termination;
- Is adjudged bankrupt and the court consents to the Contract termination; or
- Otherwise fails or refuses to faithfully perform the Contract according to its terms and conditions.

If the Contract is terminated by the City, upon demand the Contractor and Contractor's Surety shall provide the City with immediate and peaceful possession of the Project Site, and of all materials and equipment to be incorporated into the Work, whether located on and off the Project Site, for which the Contractor received progress payments.

If the Contract is terminated for default, neither the Contractor nor its Surety shall be:

- Relieved of liability for damages or losses suffered by the City because of the Contractor's breach of Contract; or
- Entitled to receive any further progress payments until the Work is completed. However, progress payments for completed Work that remain due and owing at the time of Contract termination may be made according to the City's payment terms, except that the City will be entitled to withhold sufficient funds to cover costs incurred by the City as a result of the termination. Final payment to the Contractor will be made according to the City's payment terms.

If a termination under this provision is determined by a court of competent jurisdiction to be unjustified, the termination shall be deemed a termination of public convenience.

Termination for Public Convenience

- The City may terminate the Contract in whole or in part whenever the City determines that termination of the Contract is in the best interest of the public.
- Notice: The City will provide the Contractor and the Contractor's Surety seven (7) calendar days' written notice of termination for public convenience. After such notice, the Contractor and the Contractor's Surety shall provide the City with immediate and peaceful possession of the Project Site, and of materials and equipment to be incorporated into the Work, whether located on and off the Project Site, for which the Contractor received progress payments.
- Compensation: Compensation for Work terminated by the City under this provision will be determined by the amount of Work completed/installed and materials and equipment furnished and the status of payment (paid/un-paid) for such Work, materials and equipment; less any outstanding labor or material claims against the Contractor.

Substituted Performance

According to the City's procedures, and upon the Architect's recommendation that sufficient cause exists, the City, without prejudice to any of its other rights or remedies and after giving the Contractor and the Contractor's Surety ten (10) calendar days' written notice may:

- Terminate the Contract;
- Substitute the Contractor with another Entity to complete the Contract;
- Take possession of the Project Site;
- Take possession of materials on the Project Site;
- Take possession of materials not on the Project Site, for which the Contractor received progress payments;
- Take possession of equipment on the Project Site that is to be incorporated into the Work;
- Take possession of equipment not on the Project Site that is to be incorporated into the Work, and for which the Contractor received progress payments; and
- Finish the Work by whatever method the City deems expedient.

If within the ten (10) calendar days' notice period provided above, the Contractor and/or its Surety corrects the basis for declaration of default to the satisfaction of the City, or if the Contractor's Surety submits a proposal for correction that is acceptable to the City, the Contract will not be terminated.

Assignment

Contractor shall not assign or transfer its interests in this contract without written consent of City, which consent may be withheld in the City's sole, subjective discretion; nor shall the Contractor assign any monies due or to become due to him/her hereunder without the previous written consent of the City of Central Point.

Independent Contractor – Non-Partnership

The Contractor shall perform all work under this Project as an Independent Contractor or Independent Agent and shall not be considered as an agent of the City of Central Point, nor shall the Contractor's Subcontractors or employees be sub-agents of the City of Central Point. In addition:

- The Work to be rendered under this Project is that of Independent Contractor. Contractor is not an officer, employee, or agent of the City under ORS 30.265 or ORS 30.287, and Contractor is not to be considered an officer, employee or agent of the City for any purpose. Contractor shall be solely and entirely responsible for its act and for the acts of its subcontractors, agents or employees during the performance of this Project. Contractor is an Independent Contractor for the Oregon Workers' Compensation Law (ORS Chapter 656) and is solely liable for workers' compensation coverage under any Contract/Agreement applicable to the Project.
- No Agency, Partnership or Joint Venture – Neither the City or Contractor by virtue of any Agreement applicable to this Project, is a partner or joint venture with the other party in connection with the activities carried out under this Project.
- Any Contract/Agreement applicable to this Project is not intended to entitle the Contractor nor any of its Subcontractors to any benefits generally granted to City Employees. **Contractor shall be responsible for all federal or state taxes** applicable to compensation or payment paid to Contractor under any Contract/Agreement applicable to this Project.

Force Majeure

Contractor shall not be held responsible for delay or default caused by fire, riot, act of God and war which is beyond Contractor's reasonable control. Contractor shall, however, make all reasonable efforts to remove or eliminate such a cause of delay or default and shall, upon the cessation of the cause, diligently pursue performance of its obligations under the Contract.

Severability

In the event any of the provisions or portion of the Contract/Agreement are held to be unenforceable or invalid by any court of competent jurisdiction for any reason, such invalid or unenforceable provision shall in no way effect the validity or enforceability of the remaining provisions or portions.

Waivers

No term or condition of this Contract/Agreement shall be deemed to have been waived by any Party, unless such waiver is in writing signed by the Party charged with such waiver. Any waiver of any provision of the Contract, or any right or remedy, given on any one or more occasions shall not be deemed a waiver with respect to any other occasion. The failure of either Party to enforce any provision of the project documents shall not constitute a waiver by the City of that or any other provision.

Merger

No waiver, consent, modification or change of terms of this Contract shall bind either party unless in writing and signed by both parties. A waiver, consent, modification or change, if made shall be effective only in the specific instance and for the specific purpose given. There are no understandings, agreements, or representations, oral or written, not specified herein regarding this Contract. Contractor by signature of its authorized representative hereby acknowledge that Contractor understands the Contract and agrees to be bound by its terms and conditions.

Limitation of Authority

City retains its authority to execute all applications, contracts and other documents relating to the Project. Contractor has no right or authority, express or implied, to commit or otherwise obligate City or any of its partners, except as permitted by the express terms of this Contract, or as authorized in writing.

Attorney Fees and Governing Law

In the event an action, suit or proceeding, including appeal, is brought for failure to observe any of the terms of this Contract, each party shall be responsible for that party's own attorney fees, expenses, costs and disbursements for the action, suit, proceeding or appeal. The provisions of this Contract shall be construed in accordance with the provisions of the laws of the State of Oregon. Any action or suits involving any question arising under this Contract must be brought in the appropriate court of the State of Oregon.

Remedies

The remedies provided for in the Contract are cumulative, and in addition to other remedies available at law. Contractor agrees that, due to the health, safety and welfare issues that relate to timely and acceptable completion of the Project to be constructed under this Contract, the City may not have an adequate remedy at law in the event of a breach of this Contract by Contractor, and that the City may obtain injunctive relief at the sole elections of the City.

Counterparts

The Contract may be signed in one or more counterparts (including change orders), each of which shall be an original and all of which, when taken together, shall constitute one and the same instrument.

Gender: Singular - Plural

Whenever masculine, feminine, neuter, singular, plural, conjunctive, or disjunctive terms are used in the Contract, they shall be construed to read in whatever form is appropriate to make the Contract applicable to all the Parties and all circumstances, except where the context of the Contract clearly dictates otherwise.

Interchangeable Terms in Contract and Related Documents

Contract and Agreement are interchangeable; City and Owner are interchangeable; and Architect and Engineer, are interchangeable – this can be further construed to include Project Manager and Building Official and or the designee of the Building Official (collectively, an authorized official of the City of Central Point).

Notices

All notices of a legal nature shall be in writing and shall be served upon the other party by personal service, by facsimile transmission, E-Mail followed by mail delivery of the original of such notice, by overnight courier with proof of receipt, or by certified mail, return receipt requested, postage prepaid, addressed as follows: City of Central Point, 140 South Third Street, Central Point OR 97502, Attn: City Manager, Phone: 541-664-3321. Service by mail shall be deemed complete on the date of actual delivery or three (3) business days after being sent via certified mail. Service by facsimile transmission or E-Mail shall be deemed served up receipt of the facsimile or E-Mail, followed by mail delivery.



Complete Agreement

This Agreement and attached exhibits constitutes the entire Agreement between the parties. No waiver, consent, modification, or change of terms of this Agreement shall bind either party unless in writing and signed by both parties. Such waiver, consent, modification, or change if made, shall be effective only in specific instances and for the specific purpose given. There are no understandings, agreements, or representations, oral or written, not specified herein regarding this Agreement. Contractor, by the signature of its authorized representative, hereby acknowledges that he has read this Agreement, understands it and agrees to be bound by its terms and conditions.

IN WITNESS WHEREOF, the City has caused this Agreement to be executed by its duly authorized undersigned officer and the Contractor has executed this Agreement on the date herein above first written.

CONTRACTOR: _____

BY: _____

TITLE: _____

DATE: _____

CITY OF CENTRAL POINT, OREGON

BY: _____

TITLE: CITY

MANAGER DATE: _____

DEPARTMENTAL AUTHORIZATION – CITY OF CENTRAL POINT – BUILDING DIV.

BY: _____

TITLE: BUILDING OFFICIAL

DATE: _____

Attachment: Council Chambers Renovation Contract (1157 : City Council Chambers Renovation Project Contract Approval)

RESOLUTION NO. _____

A RESOLUTION OF THE CITY COUNCIL OF THE CITY OF CENTRAL POINT, OREGON, ACTING AS THE LOCAL CONTRACT REVIEW BOARD, APPROVING THE AWARD OF A CONTRACT FOR THE CITY COUNCIL CHAMBERS RENOVATION PROJECT TO OUTLIER CONSTRUCTION, LLC.

RECITALS:

- A. The City of Central Point has identified the City Council Chambers Renovation Project in the 2019-2021 biennial budget.
- B. Central Point Municipal Code Chapter 2.40 identifies the City Council’s authority as the local contract review board.
- C. An intermediate selection process consistent with Oregon Revised Statute (ORS) 279A.065 was used to determine a qualified bidder/contractor.

THE CITY OF CENTRAL POINT RESOLVES AS FOLLOWS:

Section 1. Authorizing the City Manager, or their designee, to execute a contract with Outlier Construction, Inc. for the construction of the City Council Chambers Renovation Project.

Passed by the Council and signed by me in the authentication of its passage this _____ day of June 2019.

Mayor Hank Williams

ATTEST:

City Recorder

Attachment: Council Chambers Renovation Resolution (1157 : City Council Chambers Renovation Project Contract Approval)



City of Central Point **Staff Report to Council**

ISSUE SUMMARY

| | | |
|-------------------------|--|------------------------|
| TO: | City Council | DEPARTMENT: |
| | | Public Works |
| FROM: | Matt Samitore, Parks and Public Works Director | |
| MEETING DATE: | June 27, 2019 | |
| SUBJECT: | Community Center - Ad Hoc Committee Recommendation | |
| ACTION REQUIRED: | Information/Direction | RECOMMENDATION: |
| | | Approval |

BACKGROUND INFORMATION: City Council in 2018 created a Community Center Ad-Hoc Committee. The job of the ad-hoc committee was to prioritize the amenities of a Community Center with the monies potentially available for construction.

The Committee quickly focused that the building was the main priority and that a community swimming pool couldn't be funded at this time.

The Ad Hoc Committee reviewed several potential floor plans and made the following suggestions:

- 1 full-size basketball court
- 2 multi-purpose courts
- 2 classrooms – moveable center wall will allow for larger group meetings/conferences.
- Snack bar or commercial kitchen
- Dining area and Senior Center area
- Office Space
- Restrooms
- Storage Space

The Community Center Ad Hoc Committee reviewed the potential community center uses below:

- **Senior Center: Classes, lunch, music, senior resources**
The committee feels that a senior center would be an important component of the community center. Senior Center could operate mornings in the facility and provide lunch, classes, and senior resources. No membership requirements – open to all. Possibly provide indoor walking track around both gyms for morning exercise program.
- **Kitchen Facilities including dining area for senior center, cooking classes, snack bar**
Need to have kitchen facilities and dining area to serve Senior Center. No need for

teaching kitchen. Size should be minimized to meet needs of the Senior Center and to provide an area for food prep for events. The committee also agreed that a snack bar serving community center visitors would be good idea. This could be contracted out or staffed by nonprofit volunteers.

- **Adult and Kid Recreation Leagues (Gymnasiums): Basketball, pickleball, volleyball:**
 The gymnasiums are recommended to be a required element of the community center. The committee would like to keep the two gym configuration although some adjustments may be necessary related to total sq. ft. Need to research types of surfaces available that will allow greatest flexibility and how best to configure lines for variety of uses including basketball, indoor soccer, pickleball, volleyball, etc. Possibility of raised walking path was discussed.
- **Adults and Kids Exercise Classes & Recreation Programs (Classrooms): Yoga, Pilates, dance, martial arts, arts and crafts, science, computers, etc.**
 Classrooms are another required element. Committee wants to provide maximum flexibility with room separators and flexible flooring options. Rooms will need to be designed with both exercise and craft classes in minds. One classroom needs to be setup with presentations in mind – projector or large TV monitor. Depending on cost may provide for computer hookups, etc. An important element for all classroom space will be providing adequate storage space and furnishings.
- **Aerobic and Weight Training Exercise Classes (Elliptical and weight machines, etc.)**
 Committee was not supportive of an aerobic/weight training room. It would compete with local businesses and there are issues involved with staffing such a facility and liability issues as well.
- **Conferences & Meetings**
 The committee is supportive of providing space for conferences and meetings as long as these events do not conflict with recreational use.
- **Special Events: City uses, rental for other organization events, weddings, family gatherings**
 The committee is supportive of using facilities for special events, although scheduling around recreation activities may be an issue. Soundproofing may be an issue.
- **Walking Track**
 The committee liked the idea of providing a walking track. One idea was a track that would be located above the gymnasium bleachers but this was thought to be too expensive. The other option would be to provide a track around both gymnasium floors which could be used in the early morning before any other activities began in the gyms. An outdoor walking track could possibly be created around the facility for use when weather allows.
- **Climbing Wall**
 The committee did not support the concept of a climbing wall. They agreed that a climbing wall would be problematic, requiring constant staffing and would be a liability concern as well.
- **Swimming Pool**
 Concerning a swimming pool on the community center site, the committee felt

that the construction costs would be high and staffing and maintenance would be problematic. A regional swimming pool would be a preferred option but currently Jackson County has other priorities and the City of Medford is considering a swim center of its own. Committee agreed that a pool could still be a part of the site but could be added at a later date.

- **Spray park**

A spray park would be relatively inexpensive to add to the community center site and would provide a needed recreation facility for the neighborhood. Committee members suggested that a spray park might be better placed at the current senior center location if that facility was no longer needed.

FINANCIAL ANALYSIS: There will be a cost associated with the Ad-Hoc Committee's next steps on hiring a consultant. These costs were budgeted in the 19-21 FY budget.

LEGAL ANALYSIS:

COUNCIL GOALS/STRATEGIC PLAN ANALYSIS:

STAFF RECOMMENDATION: The Ad-Hoc Committee's recommendation is to hire a consultant to put together a series of diagrams and cost estimates for 8 million dollar range. Once prepared, allow for a series of open houses/discussions to gauge community support and bring back formal recommendations on a bond for a center or not after further community engagement is complete.

RECOMMENDED MOTION:

ATTACHMENTS:

1. 1152_presentation-20170418 (3)
2. Community Center Rendering 6-4-19
3. Community Center Configuration for Discussion Only 6-4-19



P2.01 conceptual site plan

central point community center
southeast corner cedar and s. 4th streets; central point, oregon 97502
18 april 2017

© 2017 O & W | Architecture, AIA

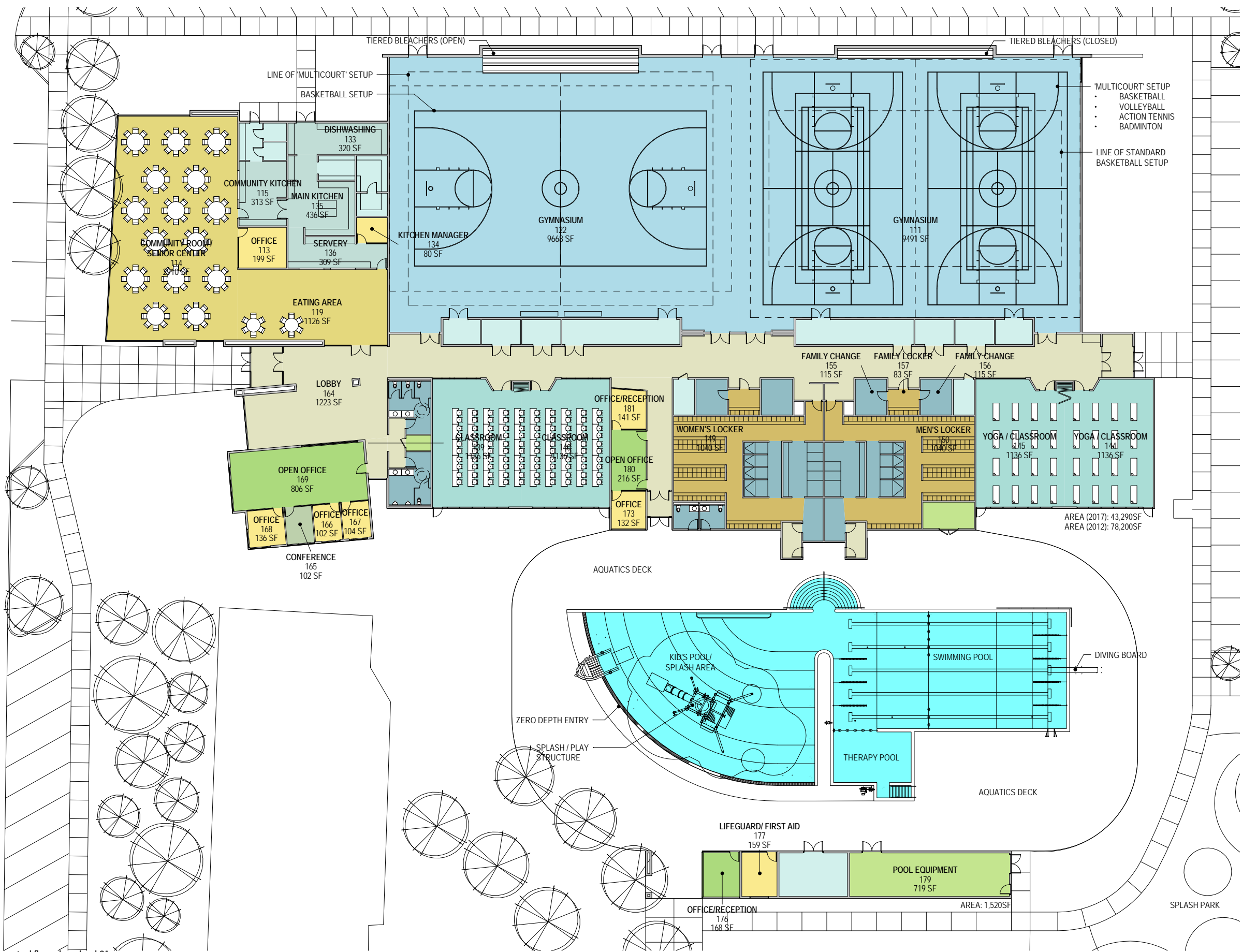

Room Type

- CIRCULATION
- CLASSROOM
- COMMUNITY / SENIOR
- GYMNASIUM
- KITCHEN
- LOCKER
- MEETING
- OFFICE, OPEN
- OFFICE, PRIVATE
- RESTROOM
- STORAGE
- UTILITY

P3.01 conceptual floor plan - level 01

central point community center
southeast corner cedar and s. 4th streets; central point, oregon 97502
18 april 2017

NEIGHBORHOOD FORMS



AGRARIAN HERITAGE



SIMPLICITY



Attachment: 1152_presentation-20170418 (3) (1159 : Community Center - Ad Hoc Committee Recommendation)

P4.01 precedent images - barns

central point community center
southeast corner cedar and s. 4th streets; central point, oregon 97502

18 april 2017

© 2017 O & W | Architecture, AIA

COLLABORATIVE APPROACH - HON

NATURAL MATERIALS



NORTHWEST FEEL



REGIONAL PRODUCTS



P4.02 precedent images - sheds

central point community center
southeast corner cedar and s. 4th streets; central point, oregon 97502

18 april 2017

© 2017 O & W | Architecture, AIA



Attachment: 1152_presentation-20170418 (3) (1159 : Community Center - Ad Hoc Committee Recommendation)



Attachment: Community Center Rendering 6-4-19 (1159 : Community Center - Ad Hoc Committee Recommendation)

CENTRAL POINT COMMUNITY CENTER
FLOOR PLAN EXAMPLE
June 3, 2019

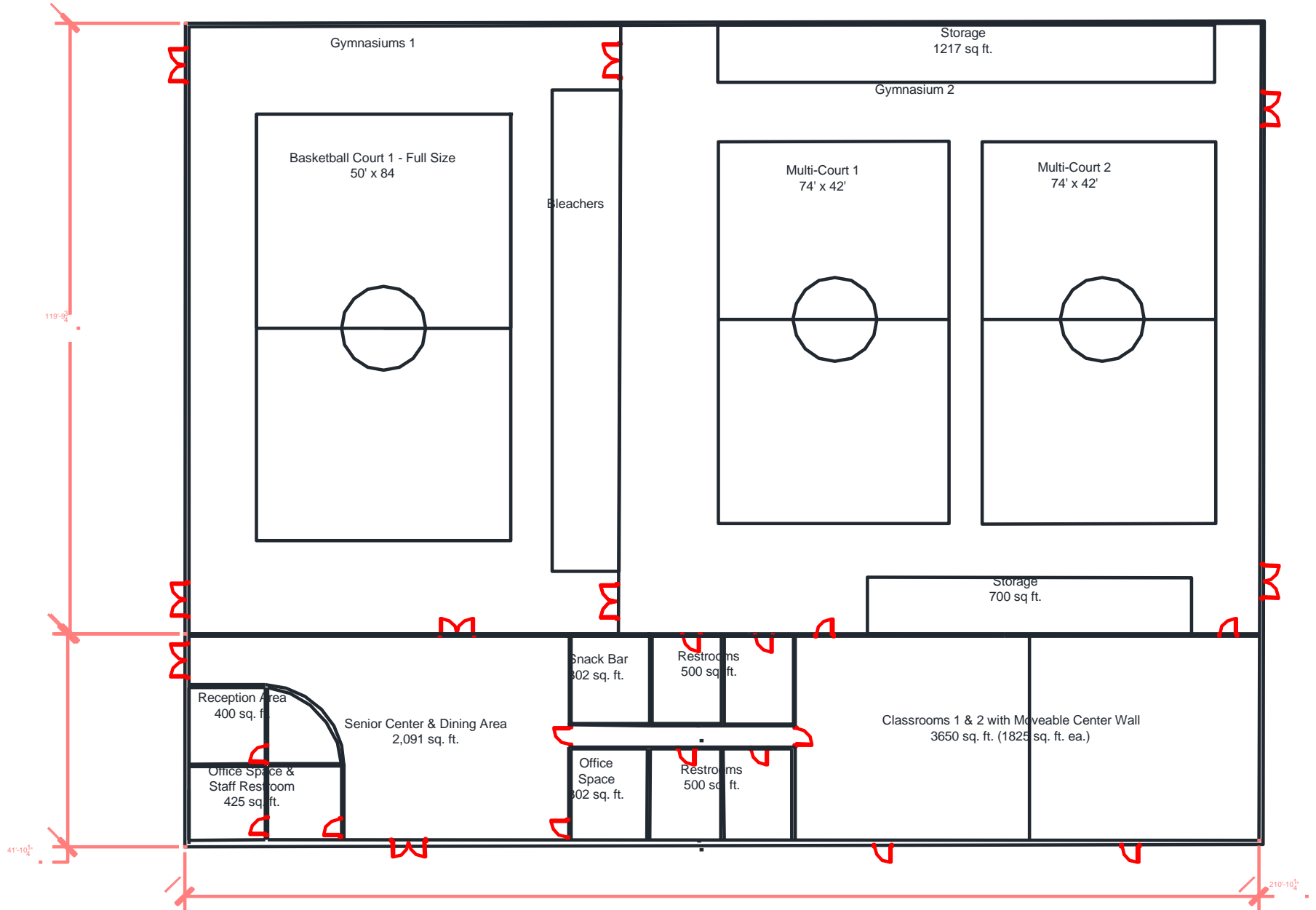

Attachment: Community Center Configuration for Discussion Only 6-4-19 (1159 : Community Center - Ad



City of Central Point Staff Report to Council

ISSUE SUMMARY

| | | | |
|-------------------------|--|------------------------|--------------|
| TO: | City Council | DEPARTMENT: | Public Works |
| FROM: | Matt Samitore, Parks and Public Works Director | | |
| MEETING DATE: | June 27, 2019 | | |
| SUBJECT: | Parks Banking - East Side Transit Oriented Development | | |
| ACTION REQUIRED: | Information/Direction | RECOMMENDATION: | Approval |

BACKGROUND INFORMATION: Areas zoned for Transit Oriented Development (TOD) are required to dedicate 200-400 sq. Ft of open space per dwelling unit as part of their subdivision plans. This process has worked well for Twin Creeks where there was an overall master plan for the 200 plus acres, which allowed a series of public and private open spaces to be created as the development progressed. Unfortunately, the eastside TOD located between Hamrick and Gebhard Roads (see map below) does not have one developer, but a series of individual developments. If left to develop individually, this area will develop with a smaller combination of public and private park facilities.

Staff is suggesting looking at a parks banking option as an idea to create one large park located around the park that is scheduled to be dedicated as part of White Hawk Estates. Instead of building private parks, area developers would pay the City for the price per sq. Ft into a separate parks reserve fund. Those monies would be used to acquire land around the White Hawk Development to expand the aforementioned park. Land negotiations would need to occur with both the Picollo and Himmelman estates for this option to be viable. Initial estimates indicate the additional area would need to be 2-3 acres in size.

The Parks Commission reviewed the idea at the May Parks Commission meeting and recommended the idea be forwarded to City Council.

FINANCIAL ANALYSIS: There would be a cost associated with a potential first right of refusal.

LEGAL ANALYSIS:

COUNCIL GOALS/STRATEGIC PLAN ANALYSIS: Goal 2- Provide high-quality facilities, parks, and open spaces that attract resident and non-resident use. Strategies: a. Prepare a finance program to maintain and expand recreation facilities, including fees, donations (land and money), sponsorships, levies, taxes, and government support.

STAFF RECOMMENDATION: Staff recommends approving the concept and directing staff to investigate land needs and the potential cost of first right of refusal.

RECOMMENDED MOTION: N/A.

ATTACHMENTS:

1. etod1
2. etod2

GEBH

NEW HAVEN RD

Don J s Pa

ETOD

Attachment: etod1 (1158 : Parks Banking)

Legend

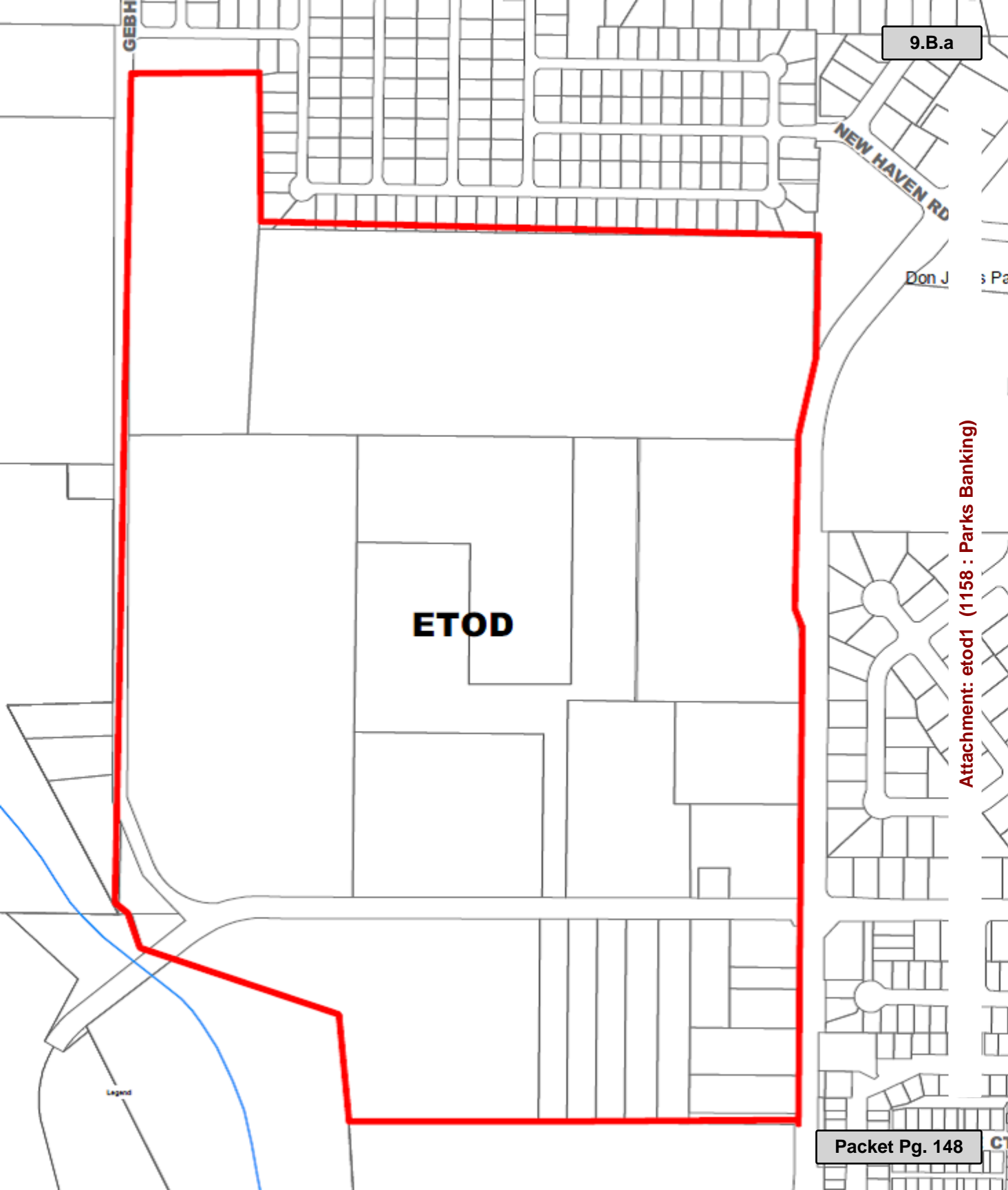

White Hawk Park

Concept Park Banking Area
"Piccolo Park"

Attachment: etod2 (1158 : Parks Banking)

